85056A 2.4 mm Calibration Kit

Notices

© Keysight Technologies, Inc.
1996-2024

No part of this manual may be reproduced in any form or by any means (including electronic storage and retrieval or translation into a foreign language) without prior agreement and written consent from Keysight Technologies, Inc. as governed by United States and international copyright laws.

Trademark Acknowledgments

n/a

Manual Part Number

85056-90020

Edition

Edition 4, January 2024

Printed in USA/Malaysia

Published by:
Keysight Technologies
1400 Fountaingrove Parkway
Santa Rosa, CA 95403

Warranty

THE MATERIAL CONTAINED IN THIS DOCUMENT IS PROVIDED "AS IS," AND IS SUBJECT TO BEING CHANGED, WITHOUT NOTICE, IN FUTURE EDITIONS. FURTHER, TO THE MAXIMUM EXTENT PERMITTED BY APPLICABLE LAW, KEYSIGHT DISCLAIMS ALL WARRANTIES, EITHER EXPRESS OR IMPLIED WITH REGARD TO THIS MANUAL AND ANY INFORMATION CONTAINED HEREIN, INCLUDING BUT NOT LIMITED TO THE IMPLIED WARRANTIES OF MERCHANTABILITY AND FITNESS FOR A PARTICULAR PURPOSE. KEYSIGHT SHALL NOT BE LIABLE FOR ERRORS OR FOR INCIDENTAL OR CONSEQUENTIAL DAMAGES IN CONNECTION WITH THE FURNISHING, USE, OR PERFORMANCE OF THIS DOCUMENT OR ANY INFORMATION CONTAINED HEREIN. SHOULD KEYSIGHT AND THE USER HAVE A SEPARATE WRITTEN AGREEMENT WITH WARRANTY TERMS COVERING THE MATERIAL IN THIS

DOCUMENT THAT CONFLICT WITH THESE TERMS, THE WARRANTY TERMS IN THE SEPARATE AGREEMENT WILL CONTROL.

Technology Licenses

The hardware and/or software described in this document are furnished under a license and may be used or copied only in accordance with the terms of such license.

U.S. Government Rights

The Software is "commercial computer software," as defined by Federal Acquisition Regulation ("FAR") 2.101. Pursuant to FAR 12.212 and 27.405-3 and Department of Defense FAR Supplement ("DFARS") 227.7202, the U.S. government acquires commercial computer software under the same terms by which the software is customarily provided to the public. Accordingly, Keysight provides the Software to U.S. government customers under its standard commercial license, which is embodied in its End User License Agreement (EULA), a copy of which can be found at

<http://www.keysight.com/find/sweula>. The license set forth in the EULA represents the exclusive authority by which the U.S. government may use, modify, distribute, or disclose the Software. The EULA and the license set forth therein, does not require or permit, among other things, that Keysight: (1) Furnish technical information related to commercial computer software or commercial computer software documentation that is not customarily provided to the public; or (2) Relinquish to, or otherwise provide, the government rights in excess of these rights customarily provided to the public to use, modify, reproduce, release, perform, display, or disclose commercial computer software or commercial computer software documentation. No additional government requirements beyond those set forth in the EULA shall apply, except to the extent that those terms, rights, or licenses are explicitly required from all providers of commercial computer software pursuant to the FAR and the DFARS and are set forth specifically in

writing elsewhere in the EULA. Keysight shall be under no obligation to update, revise or otherwise modify the Software. With respect to any technical data as defined by FAR 2.101, pursuant to FAR 12.211 and 27.404.2 and DFARS 227.7102, the U.S. government acquires no greater than Limited Rights as defined in FAR 27.401 or DFAR 227.7103-5 (c), as applicable in any technical data.

Safety Notices

CAUTION

A **CAUTION** notice denotes a hazard. It calls attention to an operating procedure, practice, or the like that, if not correctly performed or adhered to, could result in damage to the product or loss of important data. Do not proceed beyond a **CAUTION** notice until the indicated conditions are fully understood and met.

WARNING

A **WARNING** notice denotes a hazard. It calls attention to an operating procedure, practice, or the like that, if not correctly performed or adhered to, could result in personal injury or death. Do not proceed beyond a **WARNING** notice until the indicated conditions are fully understood and met.

NOTE

A **NOTE** calls the user's attention to an important point or special information in the text.

1. General Information

Calibration Kit Overview 1-1

 Kit Contents 1-1

 Broadband Loads 1

 Offset Opens and Shorts 1

 Adapters 2

 Sliding Loads 2

 Calibration Definitions 1-2

 Installation of the Calibration Definitions 3

 Equipment Required but Not Supplied 1-3

Incoming Inspection 1-3

Recording the Device Serial Numbers 1-4

Precision Slotless Connectors 1-5

Clarifying the Terminology of a Connector Interface 1-6

Preventive Maintenance 1-6

When to Calibrate 1-7

2. Specifications

Environmental Requirements 2-2

 Temperature—What to Watch Out For 2-2

Mechanical Characteristics 2-3

 Pin Depth 2-3

Electrical Specifications 2-5

 Residual Errors after Calibration 2-6

 Certification 2-6

3. Use, Maintenance, and Care of the Devices

Electrostatic Discharge 3-2

Visual Inspection 3-4

 Look for Obvious Defects and Damage First 3-4

 What Causes Connector Wear? 4

 Inspect the Mating Plane Surfaces 3-4

 Inspect Female Connectors 3-5

Cleaning Connectors 3-5

Gaging Connectors 3-8

 Connector Gage Accuracy 3-8

 When to Gage Connectors 3-9

 Gaging Procedures 3-10

 Gaging 3.5 mm Connectors 10

 Gaging the 3.5 mm Sliding Loads 13

 Adjusting the Sliding Load Pin Depth 16

Contents

| | |
|--|------|
| Connections | 3-18 |
| How to Make a Connection | 3-18 |
| Preliminary Connection | 18 |
| Final Connection Using a Torque Wrench | 19 |
| Connecting the Sliding Load | 20 |
| How to Separate a Connections | 3-22 |
| Using the Sliding Load | 3-23 |
| Handling and Storage | 3-25 |
| | |
| 4. Performance Verification | |
| Introduction | 4-2 |
| How Keysight Verifies the Devices in Your Kit | 4-3 |
| Recertification | 4-4 |
| How Often to Recertify | 4-4 |
| Where to Send a Kit for Recertification | 4-4 |
| | |
| 5. Troubleshooting | |
| Troubleshooting Process | 5-2 |
| Where to Look for More Information | 5-3 |
| Returning a Kit or Device to Keysight | 5-4 |
| Contacting Keysight | 5-5 |
| | |
| 6. Replaceable Parts | |
| Introduction | 6-2 |
| | |
| A: Standard Definitions | |
| Class Assignments and Standard Definitions Values are Available on the Web | A-1 |

1 General Information

Calibration Kit Overview

The Keysight 85056A 2.4 mm calibration kit is used to calibrate Keysight network analyzers up to 50 GHz for measurements of components with 2.4 mm connectors.

Kit Contents

The 85056A calibration kit includes the following items:

- offset opens and shorts
- broadband and sliding load terminations
- 2.4 mm adapters
- 2.4 mm gage sets
- 5/16 in, 90 N-cm (8 in-lb) torque wrench
- 7 mm open-end wrench
- User's and Service Guide (this document)
- Calibration kit storage case

Refer to **Chapter 6, "Replaceable Parts,"** for a complete list of kit contents and their associated part numbers.

Broadband Loads

The broadband loads are metrology-grade, 50 Ω terminations that have been optimized for performance up to 50 GHz. The rugged internal structure provides for highly repeatable connections. A distributed resistive element on sapphire provides excellent stability and return loss.

Offset Opens and Shorts

The offset opens and shorts are built from parts that are machined to the current state-of-the-art in precision machining.

The offset short's inner conductors have a one-piece construction, common with the shorting plane. The construction provides for extremely repeatable connections.

The offset opens have inner conductors that are supported by a strong, low-dielectric-constant plastic to minimize compensation values.

Both the opens and shorts are constructed so that the pin depth can be controlled very tightly, thereby minimizing phase errors. The lengths of the offsets in the opens and shorts are designed so that the difference in phase of their reflection coefficients is approximately 180 degrees at all frequencies.

Adapters

Like the other devices in the kit, the adapters are built to very tight tolerances to provide good broadband performance and to ensure stable, repeatable connections.

The adapters are designed so that their nominal electrical lengths are the same, allowing them to be used in calibration procedures for non-insertable devices.

Sliding Loads

The sliding loads in this kit are designed to provide excellent performance from 4 GHz to 50 GHz. The inner and outer conductors of the airline portion are precision machined to state-of-the-art tolerances. Although the sliding load has exceptional return loss, its superior load stability qualifies it as a high-performance device.

The sliding load was designed with the ability to extend the inner conductor for connection purposes and then pull it back to a preset pin depth. This feature is critical since it minimizes the possibility of damage during connection, while maintaining a minimum pin depth to optimize performance.

Calibration Definitions

The calibration kit must be selected and the calibration definitions for the devices in the kit installed in the network analyzer prior to performing a calibration.

The calibration definitions can be:

- resident within the analyzer
- manually entered from the front panel

Class assignments and standard definitions may change as more accurate model and calibration methods are developed. You can download the most recent class assignments and standard definitions from Keysight's Calibration Kit Definitions Web page at www.na.support.keysight.com/pna/caldefs/stddefs.html.

Refer to your network analyzer user's guide or embedded Help for instructions on manually entering calibration definitions, selecting the calibration kit, and performing a calibration.

NOTE

The 8510 network analyzer is no longer being sold or supported by Keysight. However, you can download the 8510 class assignments and standard definitions from Keysight's Calibration Kit Definitions Web page at www.na.support.keysight.com/pna/caldefs/stddefs.html.

Equipment Required but Not Supplied

Some items are not supplied with the calibration kit but are required to ensure successful operation of the kit. Refer to [Table 6-2 on page 6-2](#) for ordering information.

Incoming Inspection

Verify that the shipment is complete by referring to [Table 6-1](#).

Check for damage. The foam-lined storage case provides protection during shipping. Verify that this case and its contents are not damaged.

If the case or any device appears damaged, or if the shipment is incomplete, contact Keysight Technologies—see [“Contacting Keysight” on page 5-3](#). Keysight will arrange for repair or replacement of incomplete or damaged shipments without waiting for a settlement from the transportation company.

When you send the kit or device to Keysight, include a service tag (found near the end of this manual) with the following information:

- your company name and address
- the name of a technical contact person within your company, and the person's complete phone number
- the model number and serial number of the kit
- the part number and serial number of the device
- the type of service required
- a **detailed** description of the problem

Recording the Device Serial Numbers

In addition to the kit serial number, the devices in the kit are individually serialized (serial numbers are labeled onto the body of each device). Record these serial numbers in

Table . Recording the serial numbers will prevent confusing the devices in this kit with similar devices from other kits.

The adapters included in the kit are for measurement convenience only and are not serialized.

Table 1-1 **Serial Number Record for the 85056A**

| Device | Serial Number |
|---------------------------|---------------|
| Calibration kit | _____ |
| -m- open | _____ |
| -f- open | _____ |
| -m- short | _____ |
| -f- short | _____ |
| -m- broadband load | _____ |
| -f- broadband load | _____ |
| -m- sliding load | _____ |
| -f- sliding load | _____ |
| -m- to -m- 2.4 mm adapter | _____ |
| -m- to -f- 2.4 mm adapter | _____ |
| -f- to -f- 2.4 mm adapter | _____ |

Precision Slotless Connectors

The female 2.4 mm connectors in this calibration kit are metrology-grade, precision slotless connectors (PSC). A characteristic of metrology-grade connectors is direct traceability to national measurement standards through their well-defined mechanical dimensions.

Conventional female center conductors are slotted. When mated, the female center conductor is flared by the male pin. Because physical dimensions determine connector impedance, electrical characteristics of the female connector (and connection pair) are dependent upon the mechanical dimensions of the male pin. While connectors are used in pairs, their male and female halves are always specified separately as part of a standard, instrument, or device under test. Because of these facts, making precision measurements with the conventional slotted connector is very difficult, and establishing a direct traceability path to primary dimensional standards is nearly impossible.

The precision slotless connector was developed to eliminate these problems. All PSCs are female. A PSC incorporates a center conductor with a solid cylindrical shell that defines the outside diameter of the female center pin. Its outside diameter and, therefore, the impedance in its region does not change. The inner part provides an internal contact that flexes to accept the allowed range of male pin diameters.

The calibration of a network analyzer having a conventional slotted female connector on the test port remains valid only when the device under test and all calibration standards have identical male pin diameters. For this reason PSC test port adapters are supplied in most calibration kits.

Precision slotless connectors have the following characteristics:

- There is no loss of traceable calibration on test ports when the male pin diameter of the connector on the device under test is different from the male pin diameter of the calibration standard.
- The female PSC and its mating male connector can be measured and specified separately as part of the device either is attached to.
- All female connectors can have a known, stable impedance based only on the diameters of their inner and outer conductors.
- Female calibration standards can be fully specified. Their specifications and traceability are unaffected by the diameter of the male mating pin.
- A fully traceable performance verification is made using a precision 50 ohm airline having a PSC.
- Measurement repeatability is enhanced due to non-changing connector characteristics with various pin diameters.

With PSCs on test ports and standards, the percentage of accuracy achieved when measuring at 50 dB return loss levels is comparable to using conventional slotted connectors measuring devices having only 30 dB return loss. This represents an accuracy improvement of about 10 times.

Clarifying the Terminology of a Connector Interface

In this document and in the prompts of the PNA calibration wizard, the sex of cable connectors and adapters is referred to in terms of the center conductor. For example, a connector or device designated as 1.85 mm –f– has a 1.85 mm female center conductor.

8510-series, 872x, and 875x ONLY: In contrast, during a measurement calibration, the network analyzer softkey menus label a 1.85 mm calibration device with reference to the sex of the analyzer's test port connector—not the calibration device connector. For example, the label SHORT(F) refers to the short that is to be connected to the female test port. This will be a male short from the calibration kit.

Table 1-2 Clarifying the Terminology of Connectors: Examples

| Terminology | Meaning |
|-------------|---|
| Short –f– | Female short (female center conductor) |
| Short (f) | Male short (male center conductor) to be connected to female port |

A connector gage is referred to in terms of the connector that it measures. For instance, a male connector gage has a female connector on the gage so that it can measure male devices.

Preventive Maintenance

The best techniques for maintaining the integrity of the devices in the kit include:

- routine visual inspection
- cleaning
- proper gaging
- proper connection techniques

All of these are described in [Chapter 3](#). Failure to detect and remove dirt or metallic particles on a mating plane surface can degrade repeatability and accuracy and can damage any connector mated to it. Improper connections, resulting from pin depth values being out of the observed limits (see [Table on page 2-3](#)), or from bad connection techniques, can also damage these devices.

When to Calibrate

A network analyzer calibration remains valid as long as the changes in the systematic error are insignificant. This means that changes to the uncorrected leakages (directivity and isolation), mismatches (source match and load match), and frequency response of the system are small (<10%) relative to accuracy specifications.

Change in the environment (especially temperature) between calibration and measurement is the major cause in calibration accuracy degradation. The major effect is a change in the physical length of external and internal cables. Other important causes are dirty and damaged test port connectors and calibration standards. If the connectors become dirty or damaged, measurement repeatability and accuracy is affected. Fortunately, it is relatively easy to evaluate the general validity of the calibration. To test repeatability, remeasure one of the calibration standards. If you can not obtain repeatable measurements from your calibration standards, maintenance needs to be performed on the test port connectors, cables and calibration standards. Also, maintain at least one sample of the device under test or some known device as your reference device. A verification kit may be used for this purpose. After calibration, measure the reference device and note its responses. Periodically remeasure the device and note any changes in its corrected response which can be attributed to the test system. With experience you will be able to see changes in the reference responses that indicate a need to perform the measurement calibration again.

General Information
When to Calibrate

2 Specifications

Environmental Requirements

Table 2-1 Environmental Requirements

| Parameter | Limits |
|------------------------------------|---|
| Temperature | |
| Operating ^a | +20 °C to +26 °C |
| Storage | -40 °C to +75 °C |
| Error-corrected range ^b | ± 1 °C of measurement calibration temperature |
| Relative humidity | Type tested, 0% to 95% at 40 °C, non-condensing |

- a. The temperature range over which the calibration standards maintain conformance to their specifications.
b. The allowable network analyzer ambient temperature drift during measurement calibration and during measurements when the network analyzer error correction is turned on. Also, the range over which the network analyzer maintains its specified performance while correction is turned on.

Temperature—What to Watch Out For

Changes in temperature can affect electrical characteristics. Therefore, the operating temperature is a critical factor in performance. During a measurement calibration, the temperature of the calibration devices must be stable and within the range shown in

Table 2-1.

NOTE

IMPORTANT!

Avoid unnecessary handling of the devices during calibration because your fingers are a heat source.

Mechanical Characteristics

Mechanical characteristics such as center conductor protrusion and pin depth are not performance specifications. They are, however, important supplemental characteristics related to electrical performance. Keysight Technologies verifies the mechanical characteristics of the devices in the kit with special gaging processes and electrical testing. This ensures that the device connectors do not exhibit any center conductor protrusion or improper pin depth when the kit leaves the factory.

“Gaging Connectors” on page 3-8 explains how to use gages to determine if the kit devices have maintained their mechanical integrity. Refer to **Table 2-2 on page 2-3** for typical and observed pin depth limits.

Pin Depth

Pin depth is the distance the center conductor mating plane differs from being flush with the outer conductor mating plane. See **Figure 2-1**. The pin depth of a connector can be in one of two states: either protruding or recessed.

Protrusion is the condition in which the center conductor extends beyond the outer conductor mating plane. This condition will indicate a positive value on the connector gage.

Recession is the condition in which the center conductor is set back from the outer conductor mating plane. This condition will indicate a negative value on the connector gage.

Figure 2-1 Connector Pin Depth

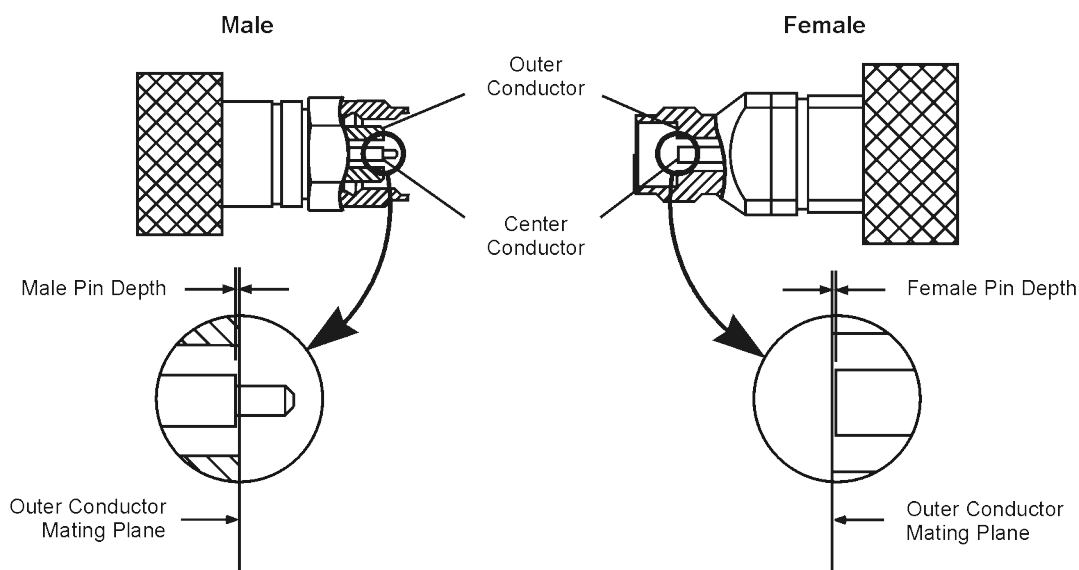

ph78a

The pin depth value of each calibration device in the kit is not specified, but is an important mechanical parameter. The electrical performance of the device depends, to some extent, on its pin depth. The electrical specifications for each device in the kit take into account the effect of pin depth on the device's performance. **Table 2-2** lists the typical pin depths and measurement uncertainties, and provides observed pin depth limits for the devices in the kit. If the pin depth of a device does not measure within the **observed** pin depth limits, it may be an indication that the device fails to meet electrical specifications. Refer to **Figure 2-1 on page 2** for a visual representation of proper pin depth (slightly recessed).

Table 2-2 Pin Depth Limits

| Device | Typical Pin Depth | Measurement Uncertainty ^a | Observed Pin Depth Limits ^b |
|---------------|--|--|--|
| Opens | 0 to -0.0127 mm 0 to -0.00050 in | +0.0030 to -0.0030 mm +0.00012 to -0.00012 in | +0.0030 to -0.0157 mm +0.00012 to -0.00062 in |
| Shorts | 0 to -0.0127 mm 0 to -0.00050 in | +0.0015 to -0.0015 mm +0.00006 to -0.00006 in | +0.0015 to -0.0142 mm +0.00006 to -0.00056 in |
| Fixed loads | -0.0025 to -0.0203 mm -0.00010 to -0.00080 in | +0.0030 to -0.0030 mm +0.00012 to -0.00012 in | +0.0005 to -0.0234 mm +0.00002 to -0.00092 in |
| Sliding loads | 0 to -0.0127 mm 0 to -0.00050 in | +0.0015 to -0.0015 mm +0.00006 to -0.00006 in | +0.0015 to -0.0142 mm +0.00006 to -0.00056 in |
| Adapters | 0 to -0.0381 mm 0 to -0.00150 in | +0.0030 to -0.0030 mm +0.00012 to -0.00012 in | +0.0030 to -0.0411 mm +0.00012 to -0.00162 in |

- a. Approximately +2 sigma to -2 sigma of gage uncertainty based on studies done at the factory according to recommended procedures.
- b. Observed pin depth limits are the range of observation limits seen on the gage reading due to measurement uncertainty. The depth could still be within specifications.

Electrical Specifications

The electrical specifications in **Table 2-3** apply to the devices in your calibration kit when connected with a Keysight precision interface.

Table 2-3 Electrical Specifications for 85056A 2.4 mm Devices

| Device | Specification | Frequency (GHz) |
|---|--|-----------------------|
| Broadband loads (male and female) | Return loss ≥ 42 dB ($\rho \leq 0.00794$) | dc to ≤ 4 |
| | Return loss ≥ 34 dB ($\rho \leq 0.01995$) | > 4 to ≤ 20 |
| | Return loss ≥ 30 dB ($\rho \leq 0.03162$) | > 20 to ≤ 26.5 |
| | Return loss ≥ 26 dB ($\rho \leq 0.05019$) | > 26.5 to ≤ 50 |
| The broadband load specifications below apply only to the following obsolete loads, no longer included in this kit: 85056-60008 (fixed load, 2.4 mm -m-), 85056-60009 (fixed load, 2.4 mm -f-), 00901-60001 (fixed load, 2.4 mm -m-), and 00901-60002 (fixed load, 2.4 mm -f-). | | |
| Broadband loads (male and female) | Return loss ≥ 42 dB ($\rho \leq 0.00794$) | dc to ≤ 4 |
| | Return loss ≥ 28 dB ($\rho \leq 0.04000$) | > 4 to ≤ 20 |
| | Return loss ≥ 24 dB ($\rho \leq 0.06300$) | > 20 to ≤ 26.5 |
| | Return loss ≥ 15 dB ($\rho \leq 0.17800$) | > 26.5 to ≤ 50 |
| Sliding loads ^a (male and female) | Return loss ≥ 42 dB ($\rho \leq 0.00794$) | 4 to ≤ 20 |
| | Return loss ≥ 40 dB ($\rho \leq 0.01000$) | > 20 to ≤ 36 |
| | Return loss ≥ 38 dB ($\rho \leq 0.01259$) | > 36 to ≤ 40 |
| | Return loss ≥ 36 dB ($\rho \leq 0.01585$) | > 40 to ≤ 50 |
| Adapters | Return loss ≥ 32 dB ($\rho \leq 0.02512$) | dc to ≤ 4 |
| | Return loss ≥ 30 dB ($\rho \leq 0.03162$) | > 4 to ≤ 26.5 |
| | Return loss ≥ 25 dB ($\rho \leq 0.05623$) | > 26.5 to ≤ 40 |
| | Return loss ≥ 20 dB ($\rho \leq 0.10000$) | > 40 to ≤ 50 |
| Offset opens ^{b,c} (male and female) | $\pm 0.5^\circ$ deviation from nominal | dc to ≤ 2 |
| | $\pm 1.25^\circ$ deviation from nominal | > 2 to ≤ 20 |
| | $\pm 1.75^\circ$ deviation from nominal | > 20 to ≤ 40 |
| | $\pm 2.25^\circ$ deviation from nominal | > 40 to ≤ 50 |
| Offset shorts ^{b,d} (male and female) | $\pm 0.50^\circ$ deviation from nominal | dc to ≤ 2 |
| | $\pm 1.25^\circ$ deviation from nominal | > 2 to ≤ 20 |
| | $\pm 1.5^\circ$ deviation from nominal | > 20 to ≤ 40 |
| | $\pm 2.0^\circ$ deviation from nominal | > 40 to ≤ 50 |
| See footnotes on the following page. | | |

Specifications

Electrical Specifications

- a. Assuming proper usage, the specifications for the residual return loss after calibration for the sliding load termination include:
 - the quality of the airline portions within the sliding load, combined with
 - the effective stability of the sliding element.Proper usage includes the following practices:
 - Connector mating surfaces are clean.
 - The changes in slide positioning are NOT done in equal steps since this results in very poor calibration for some portions of the frequency range.
 - The center conductor of test port connectors are nominally set back from the outer conductor.
 - Sliding loads are designed to allow the center conductor to be moved. The position of the sliding load center conductor should be set by a reference block and not positioned flush against the center conductor of the test port.
- b. The specifications for the opens and shorts are given as allowed deviation from the nominal model as defined in the standard definitions.
- c. These specifications also apply to the obsolete parts 85056-60003 and 85056-60004 that are no longer included in this kit.
- d. These specifications also apply to the obsolete parts 85056-60001 and 85056-60002 that are no longer included in this kit.

Certification

Keysight Technologies certifies that this product met its published specifications at the time of shipment from the factory. Keysight further certifies that its calibration measurements are traceable to the United States National Institute of Standards and Technology (NIST) to the extent allowed by the Institute's calibration facility, and to the calibration facilities of other International Standards Organization members. See **“How Keysight Verifies the Devices in Your Kit” on page 4-1** for more information.

Specifications
Electrical Specifications

3 Use, Maintenance, and Care of the Devices

Electrostatic Discharge

Protection against electrostatic discharge (ESD) is essential while connecting, inspecting, or cleaning connectors attached to static-sensitive circuits (like those found in test sets).

Static electricity can build up on your body and can easily damage sensitive internal circuit elements when discharged. Static discharges too small to be felt can cause permanent damage. Devices such as calibration components and devices under test (DUT), can also carry an electrostatic charge. To prevent damage to the test set, components, and devices:

- **Always** wear a grounded wrist strap having a 1 M Ω resistor in series with it when handling components and devices or when making connections to the test set.
- **Always** use a grounded antistatic mat in front of your test equipment.
- **Always** wear a heel strap when working in an area with a conductive floor. If you are uncertain about the conductivity of your floor, wear a heel strap.
- **always** ground yourself before you clean, inspect, or make a connection to a static-sensitive device or test port. You can, for example, grasp the grounded outer shell of the test port or cable connector briefly.
- **always** ground the center conductor of a test cable before making a connection to the analyzer test port or other static-sensitive device. This can be done as follows:
 1. Connect a short (from your calibration kit) to one end of the cable to short the center conductor to the outer conductor.
 2. While wearing a grounded wrist strap, grasp the outer shell of the cable connector.
 3. Connect the other end of the cable to the test port.
 4. Remove the short from the cable.

Figure 3-1 shows a typical ESD protection setup using a grounded mat and wrist strap. Refer to **Chapter 6, “Replaceable Parts,”** for ordering information on ESD supplies.

Figure 3-1 ESD Protection Setup

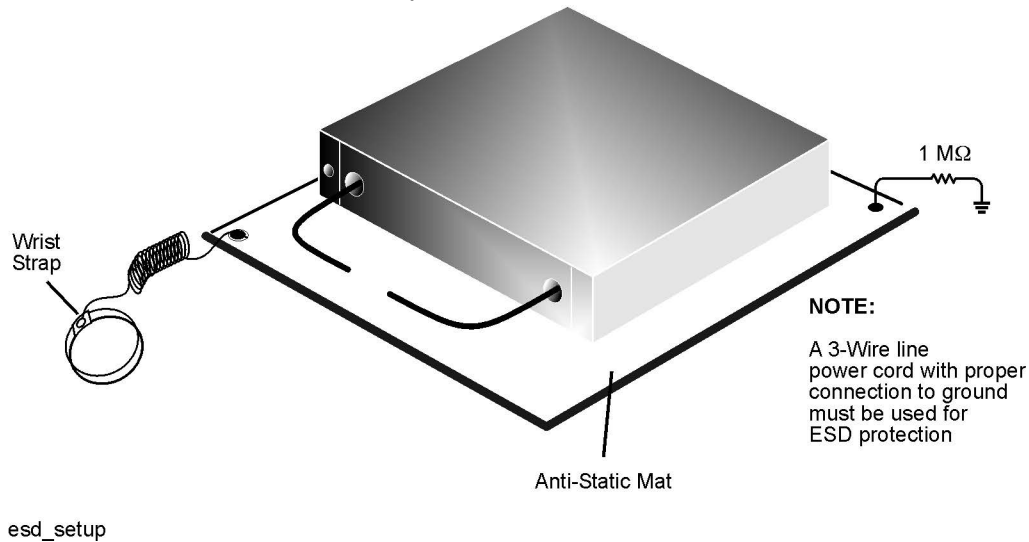

Visual Inspection

Visual inspection and, if necessary, cleaning should be done every time a connection is made. Metal particles from the connector threads may fall into the connector when it is disconnected. One connection made with a dirty or damaged connector can damage both connectors beyond repair.

Magnification is helpful when inspecting connectors, but it is not required and may actually be misleading. Defects and damage that cannot be seen without magnification generally have no effect on electrical or mechanical performance. Magnification is of great use in analyzing the nature and cause of damage and in cleaning connectors, but it is not required for inspection.

Look for Obvious Defects and Damage First

Examine the connectors first for obvious defects and damage: badly worn plating on the connector interface, deformed threads, or bent, broken, or misaligned center conductors. Connector nuts should move smoothly and be free of burrs, loose metal particles, and rough spots.

What Causes Connector Wear?

Connector wear is caused by connecting and disconnecting the devices. The more use a connector gets, the faster it wears and degrades. The wear is greatly accelerated when connectors are not kept clean, or are not connected properly.

Allowing a device to rotate while the torque is being applied is a major source of wear. It is very important to hold the backup wrench still, instead of rotating it opposite the torque wrench - refer to **“How to Make a Connection” on page 3-16**.

Connector wear eventually degrades performance of the device. Calibration devices should have a long life if their use is on the order of a few times per week. Replace devices with worn connectors.

The test port connectors on the network analyzer test set may have many connections each day, and are therefore more subject to wear. It is recommended that an adapter be used as a test port saver to minimize the wear on the test set's test port connectors.

Inspect the Mating Plane Surfaces

Flat contact between the connectors at all points on their mating plane surfaces is required for a good connection. See **Figure 2-1 on page 2-2**. Look especially for deep scratches or dents, and for dirt and metal particles on the connector mating plane surfaces. Also look for signs of damage due to excessive or uneven wear or misalignment.

Light burnishing of the mating plane surfaces is normal, and is evident as light scratches or shallow circular marks distributed more or less uniformly over the mating plane surface. Other small defects and cosmetic imperfections are also normal. None of these affect electrical or mechanical performance.

If a connector shows deep scratches or dents, particles clinging to the mating plane surfaces, or uneven wear, clean and inspect it again. Devices with damaged connectors should be discarded. Determine the cause of damage before connecting a new, undamaged connector in the same configuration.

Inspect Female Connectors

Inspect the contact fingers in the female center conductor carefully. These can be bent or broken, and damage to them is not always easy to see. A connector with damaged contact fingers will not make good electrical contact and must be replaced.

NOTE

This is particularly important when mating nonprecision to precision device.

The female 2.4 mm connectors in this calibration kit are metrology-grade, precision slotless connectors (PSC). Precision slotless connectors are used to improve accuracy. With PSCs on test ports and standards, the accuracy achieved when measuring at 50 dB return loss levels is comparable to using conventional slotted connectors measuring devices having only 30 dB return loss. This represents an accuracy improvement of about 10 times.

Conventional female center conductors are slotted and, when mated, are flared by the male pin. Because physical dimensions determine connector impedance, this change in physical dimension affects electrical performance, making it very difficult to perform precision measurements with conventional slotted female connectors.

The precision slotless connector was developed to eliminate this problem. The PSC has a center conductor with a solid cylindrical shell, the outside diameter of which does not change when mated. Instead, this center conductor has an internal contact that flexes to accept the male pin.

Cleaning Connectors

Clean connectors are essential for ensuring the integrity of RF and microwave coaxial connections.

1. Use Compressed Air or Nitrogen

WARNING

Always use protective eyewear when using compressed air or nitrogen.

Use compressed air (or nitrogen) to loosen particles on the connector mating plane surfaces. Clean air cannot damage a connector or leave particles or residues behind.

You can use any source of clean, dry, low-pressure compressed air or nitrogen that has an effective oil-vapor filter and liquid condensation trap placed just before the outlet hose.

Ground the hose nozzle to prevent electrostatic discharge, and set the air pressure to less than 414 kPa (60 psi) to control the velocity of the air stream. High-velocity streams of compressed air can cause electrostatic effects when directed into a connector. These electrostatic effects can damage the device. Refer to [“Electrostatic Discharge” on page 3-1](#) earlier in this chapter for additional information.

2. Clean the Connector Threads

WARNING

Keep isopropyl alcohol away from heat, sparks, and flame. Store in a tightly closed container. It is extremely flammable. In case of fire, use alcohol foam, dry chemical, or carbon dioxide; water may be ineffective.

Use isopropyl alcohol with adequate ventilation and avoid contact with eyes, skin, and clothing. It causes skin irritation, may cause eye damage, and is harmful if swallowed or inhaled. It may be harmful if absorbed through the skin. Wash thoroughly after handling.

In case of spill, soak up with sand or earth. Flush spill area with water.

Dispose of isopropyl alcohol in accordance with all applicable federal, state, and local environmental regulations.

Use a lint-free swab or cleaning cloth moistened with isopropyl alcohol to remove any dirt or stubborn contaminants on a connector that cannot be removed with compressed air or nitrogen. Refer to [Table 6-2 on page 6-2](#) for a part number for cleaning swabs.

- a. Apply a small amount of isopropyl alcohol to a lint-free cleaning swab.
- b. Clean the connector threads.
- c. Let the alcohol evaporate, then blow the threads dry with a gentle stream of clean, low-pressure compressed air or nitrogen. Always completely dry a connector before you reassemble or use it.

3. Clean the Mating Plane Surfaces

- a. Apply a small amount of isopropyl alcohol to a lint-free cleaning swab.
- b. Clean the center and outer conductor mating plane surfaces. Refer to [Figure 2-1 on page 2-2](#). When cleaning a female connector, avoid snagging the swab on the center conductor contact fingers by using short strokes.
- c. Let the alcohol evaporate, then blow the connector dry with a gentle stream of clean, low-pressure compressed air or nitrogen. Always completely dry a connector before you reassemble or use it.

4. Reinspect

Inspect the connector to make sure that no particles or residue remain. Refer to [“Visual Inspection” on page 3-2](#).

Review the Principles of Connector Care

WARNING

Cleaning connectors with alcohol shall only be done with the instrument power cord removed and in a well-ventilated area. Allow all residual alcohol moisture to evaporate, and the fumes to dissipate prior to energizing the instrument.

Proper connector care and connection techniques are critical for accurate and repeatable measurements. Refer to **Table 3-1** for tips on connector care.

Prior to making connections to your analyzer, carefully review the information about inspecting, cleaning, and gaging connectors. Refer to the calibration kit documentation for detailed connector care information.

For course numbers about additional connector care instruction, contact Keysight Technologies. Refer to **“Contacting Keysight” on page 5-3**.

Table 3-1 Connector Care Quick Reference Guide

| Handling and Storage | | | |
|-----------------------------|--|--------|--|
| Do | – Keep connectors clean | Do Not | – Touch mating-plane surfaces |
| | – Extend sleeve or connector nut | | – Set connectors contact-end down |
| | – Use plastic end-caps during storage | | – Store connectors or adapters loose |
| Visual Inspection | | | |
| Do | – Inspect all connectors carefully | Do Not | – Use a damaged connector - ever |
| | – Look for metal particles, scratches, and dents | | |
| Connector Cleaning | | | |
| Do | – Try compressed air first | Do Not | – Use any abrasives |
| | – Use isopropyl alcohol ^a | | – Get liquid into plastic support beads |
| | – Clean connector threads | | |
| Gaging Connectors | | | |
| Do | – Clean and zero the gage before use | Do Not | – Use an out-of-specification connector |
| | – Use the correct gage type | | |
| | – Use correct end of calibration block | | |
| | – Gage all connectors before first use | | |
| Making Connections | | | |
| Do | – Align connectors carefully | Do Not | – Apply bending force to connection |
| | – Make preliminary connection contact lightly | | – Over tighten preliminary connection |
| | – Turn only the connector nut | | – Twist or screw any connection |
| | – Use a torque wrench for final connection | | – Tighten past torque wrench “break” point |

a. Cleaning connectors with alcohol shall only be done with the instrument’s power cord removed, and in a well-ventilated area. Allow all residual alcohol moisture to evaporate, and the fumes to dissipate prior to energizing the instrument.

Gaging Connectors

The gages provided with your calibration kit are intended for preventive maintenance and troubleshooting purposes only. See [Table 6-1 on page 6-1](#) for part number information. They are effective in detecting excessive center conductor protrusion or recession, and conductor damage on DUTs, test accessories, and the calibration kit devices. Do not use the gages for precise pin depth measurements.

Connector Gage Accuracy

The connector gages are only capable of performing coarse measurements. They do not provide the degree of accuracy necessary to precisely measure the pin depth of the kit devices. This is partially due to the repeatability uncertainties that are associated with the measurement. Only the factory—through special gaging processes and electrical testing— can accurately verify the mechanical characteristics of the devices.

With proper technique, the gages are useful in detecting gross pin depth errors on device connectors. To achieve maximum accuracy, random errors must be reduced by taking the average of at least three measurements having different gage orientations on the connector. Even the resultant average can be in error by as much as ± 0.0001 inch due to systematic (biasing) errors usually resulting from worn gages and gage masters. The information in [Table 2-1 on page 2-1](#) assumes new gages and gage masters. Therefore, these systematic errors were not included in the uncertainty analysis. As the gages undergo more use, the systematic errors can become more significant in the accuracy of the measurement.

The measurement uncertainties in [Table 2-2](#) are primarily a function of the assembly materials and design, and the unique interaction each device type has with the gage. Therefore, these uncertainties can vary among the different devices. For example, note the difference between the uncertainties of the opens and shorts in [Table 2-2](#).

The observed pin depth limits in [Table 2-2](#) add these uncertainties to the typical factory pin depth values to provide practical limits that can be referenced when using the gages. See [“Pin Depth” on page 2-2](#). Refer to [“Kit Contents” on page 1-1](#) for more information on the design of the calibration devices in the kit.

NOTE

When measuring pin depth, the measured value (resultant average of three or more measurements) contains uncertainty and is not necessarily the true value. Always compare the measured value with the observed pin depth limits (which account for measurement uncertainties) in [Table 2-2 on page 2-3](#) to evaluate the condition of device connectors.

When to Gage Connectors

Gage a connector at the following times:

- Prior to using a device for the first time: record the pin depth measurement so that it can be compared with future readings. (It will serve as a good troubleshooting tool when you suspect damage may have occurred to the device.)
- If either visual inspection or electrical performance suggests that the connector interface may be out of typical range (due to wear or damage, for example).
- If a calibration device is used by someone else or on another system or piece of equipment.
- Initially after every 100 connections, and after that as often as experience indicates.

Gaging Procedures

Gaging 2.4 mm Connectors

NOTE

Always hold a connector gage by the gage barrel, below the dial indicator. This gives the best stability, and improves measurement accuracy. (Cradling the gage in your hand or holding it by the dial applies stress to the gage plunger mechanism through the dial indicator housing.)

1. Select the proper gage for your connector. Refer to [Table 6-1 on page 6-1](#) for gage part numbers.
2. Inspect and clean the gage, gage master, and device to be gaged. Refer to [“Visual Inspection”](#) and [“Cleaning Connectors”](#) earlier in this chapter.
3. Zero the connector gage (refer to [Figure 3-2](#)):
 - a. While holding the gage by the barrel, and without turning the gage or the device, connect the gage to the gage master by interconnecting the male and female connectors. Connect the nut finger tight. Do not overtighten.
 - b. Using an open-end wrench to keep the device body from rotating, use the torque wrench included in the kit to tighten the connecting nut to the specified torque. Refer to [“Final Connection Using a Torque Wrench” on page 3-17](#) for additional information.
 - c. As you watch the gage pointer, gently tap the barrel of the gage to settle the reading.

The gage pointer should line up exactly with the zero mark on the gage. If not, adjust the zero set knob until the gage pointer lines up exactly with the zero mark.

- d. Remove the gage master.
4. Gage the device connector (refer to [Figure 3-2](#)):
 - a. While holding the gage by the barrel, and without turning the gage or the device, connect the gage to the device by interconnecting the male and female connectors. Connect the nut finger-tight. Do not overtighten.
 - b. Using an open-end wrench to keep the device body from rotating, use the torque wrench included in the kit to tighten the connecting nut to the specified torque. Refer to [“Final Connection Using a Torque Wrench” on page 3-17](#) for additional information.
 - c. Gently tap the barrel of the gage with your finger to settle the gage reading.
 - d. Read the gage indicator dial. Read **only** the black \pm signs; **not** the red \pm signs.

For maximum accuracy, measure the connector a minimum of three times and take an average of the readings. After each measurement, rotate the gage a quarter-turn to reduce measurement variations that result from the gage or the connector face not being exactly perpendicular to the center axis.

- e. Compare the average reading with the observed pin depth limits in [Table 2-2 on page 2-3](#).

Figure 3-2 Gaging 2.4 mm Connectors

Note:

Although male devices are shown in this illustration, the procedure is essentially the same for female devices.

Zero the Connector Gage

- Connect the gage to the gage master.
- Torque the connecting nut.
- Gently tap the gage barrel to settle the reading.
- Using the zero set knob, adjust the gage pointer to line up exactly with the zero mark.
- Remove the gage master.

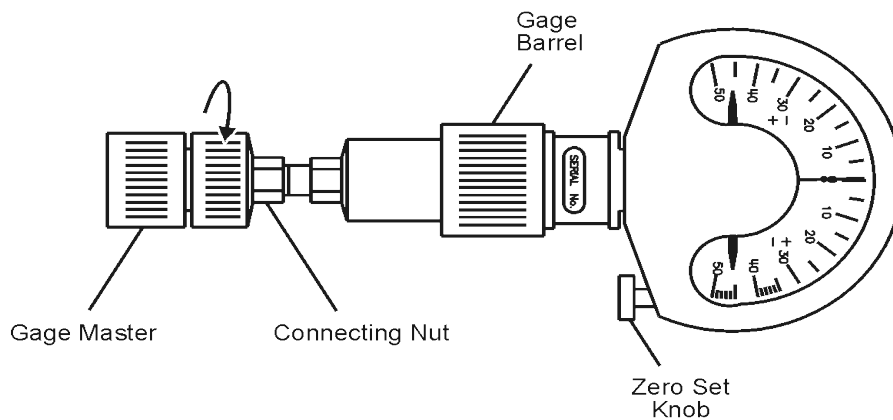

Gage the Device Connector

- Connect the gage to the device being measured.
- Torque the connecting nut.
- Gently tap the gage barrel to settle the reading.
- Read recession or protrusion from the gage.
- Remove the device.
- Repeat two additional times and average the three readings.

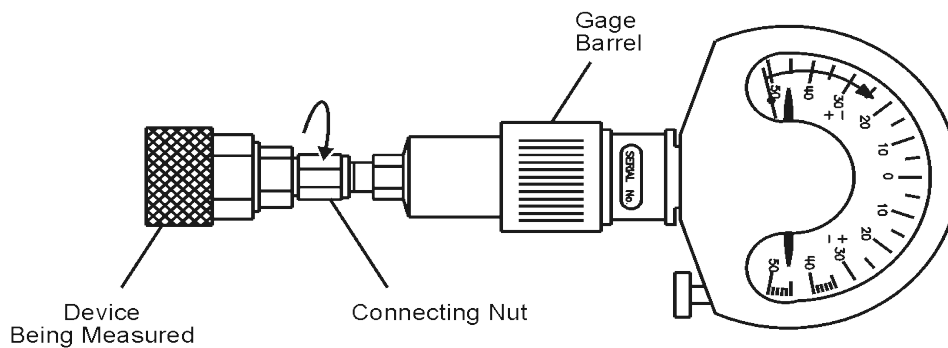

ph71a

Gaging the 2.4 mm Sliding Loads

Gage the sliding load before each use. If the sliding load pin depth is out of the observed pin depth limits listed in [Table 2-2 on page 2-3](#), refer to [“Adjusting the Sliding Load Pin Depth” on page 3-15](#).

NOTE

Always hold a connector gage by the gage barrel, below the dial indicator. This gives the best stability, and improves measurement accuracy. (Cradling the gage in your hand or holding it by the dial applies stress to the gage plunger mechanism through the dial indicator housing.)

NOTE

The sliding load uses a plastic centering bead to support its center conductor when pin depth is adjusted and gaged and when the load is stored. Remove this support bead from the sliding load before you connect the load for an electrical calibration. Reinsert this support bead when you've finished using the sliding load.

1. Select the proper gage for your connector. Refer to [Table 6-2 on page 6-2](#) for gage part numbers.
2. Inspect and clean the gage, gage master, and device to be gaged. Refer to [“Visual Inspection” on page 3-2](#) and [“Cleaning Connectors” on page 3-4](#) earlier in this chapter.
3. Zero the connector gage (refer to [Figure 3-2 on page 3-11](#)):
 - a. While holding the gage by the barrel, and without turning the gage or the device, connect the gage to the gage master by interconnecting the male and female connectors. Connect the nut finger-tight. Do not overtighten.
 - b. Using an open-end wrench to keep the device body from rotating, use the torque wrench included in the kit to tighten the connecting nut to the specified torque. Refer to [“Final Connection Using a Torque Wrench” on page 3-17](#) for additional information.
 - c. As you watch the gage pointer, gently tap the barrel of the gage to settle the reading.

The gage pointer should line up exactly with the zero mark on the gage. If not, adjust the zero set knob until the gage pointer lines up exactly with the zero mark.
 - d. Remove the gage master.
4. Gage the sliding load connector (refer to [Figure 3-3](#)):
 - a. Unlock the center conductor pullback mechanism by raising the pullback handle to the unlocked position.

- b. Carefully move the pullback mechanism toward the connector end of the sliding load. The center conductor will extend beyond the end of the connector. Continue to hold the pullback mechanism in this position.
- c. Pull the sliding ring back approximately 0.5 in and install a centering bead in the connector end of the sliding load.

CAUTION

The sliding load center conductor can be damaged if the sliding load is not in alignment with the mating connector while making the connection.

- d. Keep the center conductor extended by holding the center conductor pullback mechanism toward the connector end of the sliding load. Align the sliding load with the mating connector on the gage and mate the sliding load center conductor with the gage center conductor.
- e. Release the center conductor pullback mechanism and move the body of the sliding load toward the gage to mate the outer conductor of the sliding load connector with the outer conductor of the gage connector.
- f. Without turning the gage or the sliding load, connect the gage to the sliding load being measured by interconnecting the male and female connectors. Connect the nut finger-tight. Do not overtighten.
- g. Using an open-end wrench to keep the device body from rotating, use the torque wrench included in the kit to tighten the connecting nut to the specified torque. Refer to [“Final Connection Using a Torque Wrench” on page 3-17](#) for additional information.

CAUTION

Always move the center conductor pullback mechanism back before locking the handle. Do not force the handle past the locked position.

- h. Move the center conductor pullback mechanism back (away from the connector end of the sliding load), and place the pullback handle in its locked position.
- i. Gently tap the barrel of the gage with your finger to settle the gage reading.
- j. Read the gage indicator dial. Read **only** the black \pm signs; **not** the red \pm signs.

For maximum accuracy, measure the connector a minimum of three times and take an average of the readings. Use different orientations of the gage within the connector. After each measurement, rotate the gage a quarter-turn to reduce measurement variations that result from the gage or the connector face not being exactly perpendicular to the center axis.

- k. Compare the average reading with the observed pin depth limits in [Table 2-2 on page 2-3](#). If the pin depth is outside the limits, it must be adjusted before proceeding. Refer to [“Adjusting the Sliding Load Pin Depth” on page 3-15](#).

Figure 3-3 Gaging the 2.4 mm Sliding Loads

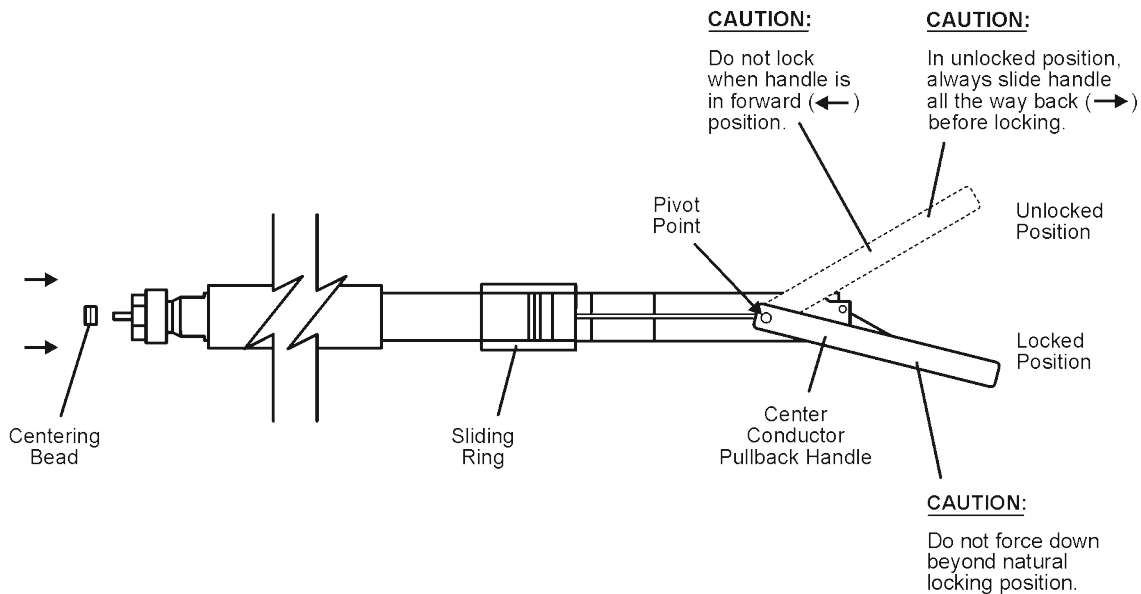

ph710a

- l. Without turning the gage or the sliding load, loosen the connection between the gage and the sliding load and remove the sliding load from the gage.

CAUTION

Damage can occur to the sliding load during the removal of a centering bead that has slipped too far into the sliding load. If you're going to perform an electrical calibration, prevent damage by removing the centering bead immediately after gaging the sliding load pin depth. The sliding load will not perform to its specifications if the centering bead is not removed from the sliding load before an electrical calibration.

- m. Leave the centering bead installed on the sliding load if you are going to adjust the pin depth. Carefully remove the centering bead from the sliding load if you're going to use it for an electrical calibration. If the centering bead does not come out of the sliding load easily:
 - i. Unlock the center conductor pullback handle and move the center conductor pullback mechanism toward the connector end of the sliding load to extend the center conductor.
 - ii. While holding the center conductor pullback mechanism toward the connector end of the sliding load, remove the centering bead.

If the centering bead still will not come out:

- i. Hold the sliding load with the connector end pointed downward.
- ii. Move the sliding ring up, then quickly down. The trapped air behind the centering bead should eject it.

Return the center conductor pullback mechanism to the rear of the sliding load and return the pullback handle to its locked position.

Adjusting the Sliding Load Pin Depth

The sliding loads in this kit have a setback mechanism that allows the pin depth to be set to any desired value. The pin depth of the sliding load is preset at the factory. **The pin depth should not have to be reset each time the sliding load is used**, but it should be checked before each use.

If the pin depth is outside the **observed** limits listed in [Table 2-2 on page 2-3](#), use the following procedure to reset it to the nominal value of -0.00381 mm (-0.00015 in).

This procedure assumes that you were directed here from [“Gaging the 2.4 mm Sliding Loads” on page 3-12](#). If not, perform the steps in that procedure before performing this procedure.

1. The gage should be attached to the sliding load. The sliding load should have its centering bead installed. Refer to [“Gaging the 2.4 mm Sliding Loads” on page 3-12](#) if necessary.
2. The face of the gage and the label on the sliding load should be facing up.
3. The center conductor pullback handle should be in the locked position.
4. With a small screwdriver, gently turn the center conductor pin depth adjustment screw until the gage pointer reads -0.00381 mm (-0.00015 in). Refer to [Figure 3-4](#) for the location of the adjustment screw.
5. Wait approximately five minutes to allow the temperature to stabilize. Do not touch either the gage or the sliding load during this time.
6. Note the gage reading. If it is no longer within the allowable range, perform step 4 again.
7. Move the center conductor pullback handle to the unlocked position and then back to the locked position. The gage reading should return to the value previously set. If not, repeat steps 4 through 7.
8. Return to [“Gaging the 2.4 mm Sliding Loads” on page 3-12](#).

Figure 3-4 Adjusting the Sliding Load Pin Depth

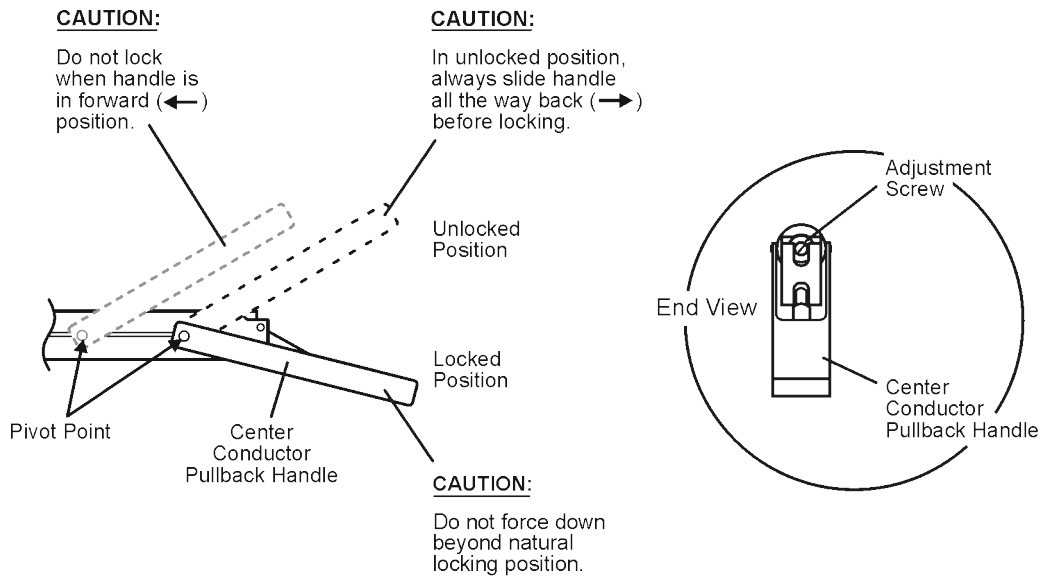

ph79a

Connections

Good connections require a skilled operator. **The most common cause of measurement error is bad connections.** The following procedures illustrate how to make good connections.

How to Make a Connection

Preliminary Connection

1. Ground yourself and all devices. Wear a grounded wrist strap and work on a grounded, conductive table mat. Refer to **“Electrostatic Discharge” on page 3-1** for ESD precautions.
2. Visually inspect the connectors. Refer to **“Visual Inspection” on page 3-2**.
3. If necessary, clean the connectors. Refer to **“Cleaning Connectors” on page 3-4**.
4. Use a connector gage to verify that all center conductors are within the observed pin depth values in **Table 2-2 on page 2-3**. Refer to **“Gaging Connectors” on page 3-8**.

5. Carefully align the connectors. The male connector center pin must slip concentrically into the contact finger of the female connector.
6. Push the connectors straight together and tighten the connector nut finger tight.

CAUTION

Do **not** turn the device body. Only turn the connector nut. Damage to the center conductor can occur if the device body is twisted.

Do **not** twist or screw the connectors together. As the center conductors mate, there is usually a slight resistance.

7. The preliminary connection is tight enough when the mating plane surfaces make uniform, light contact. Do not overtighten this connection.
A connection in which the outer conductors make gentle contact at all points on both mating surfaces is sufficient. Very light finger pressure is enough to accomplish this.
8. Make sure the connectors are properly supported. Relieve any side pressure on the connection from long or heavy devices or cables.

Final Connection Using a Torque Wrench

Use a torque wrench to make a final connection. [Table 3-2](#) provides information about the torque wrench recommended for use with the calibration kit. A torque wrench is included in the calibration kit. Refer to [Table 6-1 on page 6-1](#) for replacement part number and ordering information.

Table 3-2 Torque Wrench Information

| Connector Type | Torque Setting | Torque Tolerance |
|----------------|-------------------|--------------------------|
| 2.4 mm | 90 N-cm (8 in-lb) | ± 9.0 N-cm (± 0.8 in-lb) |

Using a torque wrench guarantees that the connection is not too tight, preventing possible connector damage. It also guarantees that all connections are equally tight each time.

Prevent the rotation of anything other than the connector nut that you are tightening. It may be possible to do this by hand if one of the connectors is fixed (as on a test port). However, it is recommended that you use an open-end wrench to keep the body of the device from turning.

1. Position both wrenches within 90 degrees of each other before applying force. See [Figure 3-5](#). Wrenches opposing each other (greater than 90 degrees apart) will cause a lifting action which can misalign and stress the connections of the devices involved. This is especially true when several devices are connected together.

Figure 3-5 Wrench Positions

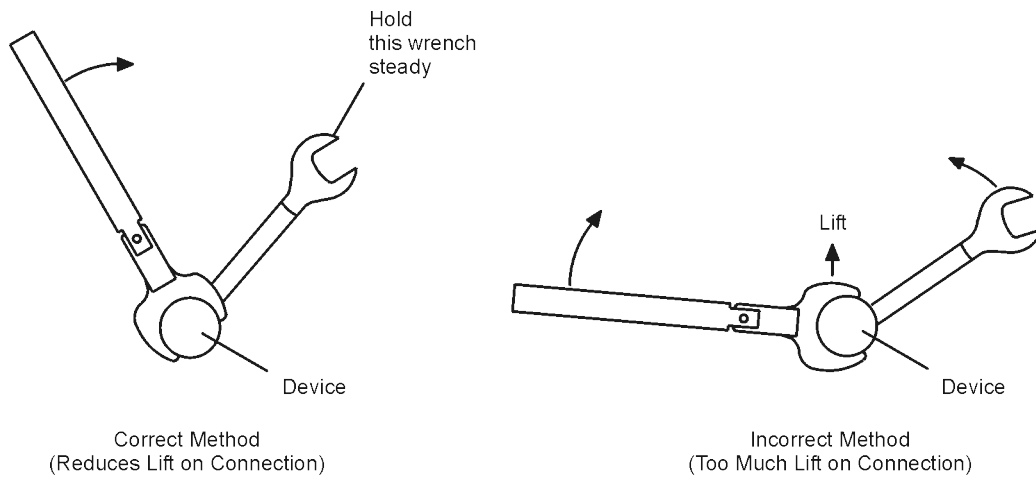

ph711a

2. Hold the torque wrench lightly, at the end of the handle only (beyond the groove). See [Figure 3-6](#).

Figure 3-6 Using the Torque Wrench

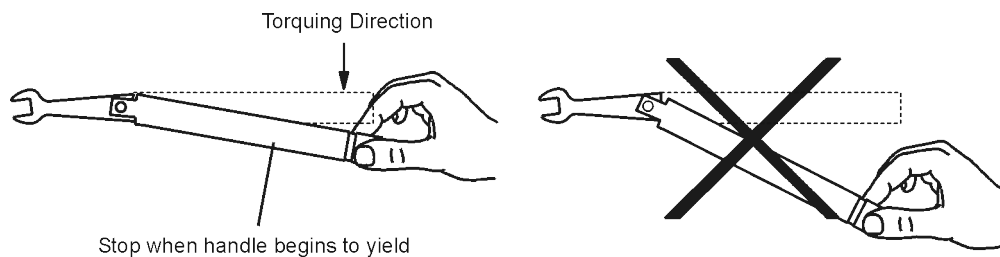

ph712a

3. Apply downward force perpendicular to the wrench handle. This applies torque to the connection through the wrench.
Do not hold the wrench so tightly that you push the handle straight down along its length rather than pivoting it, otherwise you apply an unknown amount of torque.
4. Tighten the connection just to the torque wrench break point. The wrench handle gives way at its internal pivot point. See [Figure 3-6 on page 3-18](#). Do not tighten the connection further.

CAUTION

You don't have to fully break the handle of the torque wrench to reach the specified torque; doing so can cause the handle to kick back and loosen the connection. Any give at all in the handle is sufficient torque.

Connecting the Sliding Load

1. Unlock the center conductor pullback mechanism by raising the pullback handle to the unlocked position. Refer to [Figure 3-7](#).
2. Carefully move the pullback mechanism toward the connector end of the sliding load. The center conductor will extend beyond the end of the conductor. Continue to hold the pullback mechanism in this position.

CAUTION

The sliding load center conductor can be damaged if the sliding load is not in alignment with the mating connector while making the connection.

3. Keep the center conductor extended by holding the center conductor pullback mechanism toward the connector end of the sliding load. Align the sliding load with the mating connector on the cable or test port to which it is being connected and mate the sliding load center conductor with the center conductor of the cable or test port.
4. Release the center conductor pullback mechanism and move the body of the sliding load toward the cable or test port to mate the outer conductor of the sliding load connector to the outer conductor of the cable or test port connector.
5. Without turning the sliding load, connect the sliding load to the cable or test port by interconnecting the male and female connectors. Connect the nut finger-tight. Do not overtighten.
6. Using an open-end wrench to keep the device body from rotating, use the torque wrench included in the kit to tighten the connecting nut to the specified torque. Refer to [“Final Connection Using a Torque Wrench” on page 3-17](#) for additional information.

CAUTION

Always move the center conductor pullback mechanism back before locking the handle. Do not force the handle past the locked position.

7. Move the center conductor pullback mechanism back (away from the connector end of the sliding load), and place the pullback handle in its locked position.

Figure 3-7 Connecting the Sliding Load

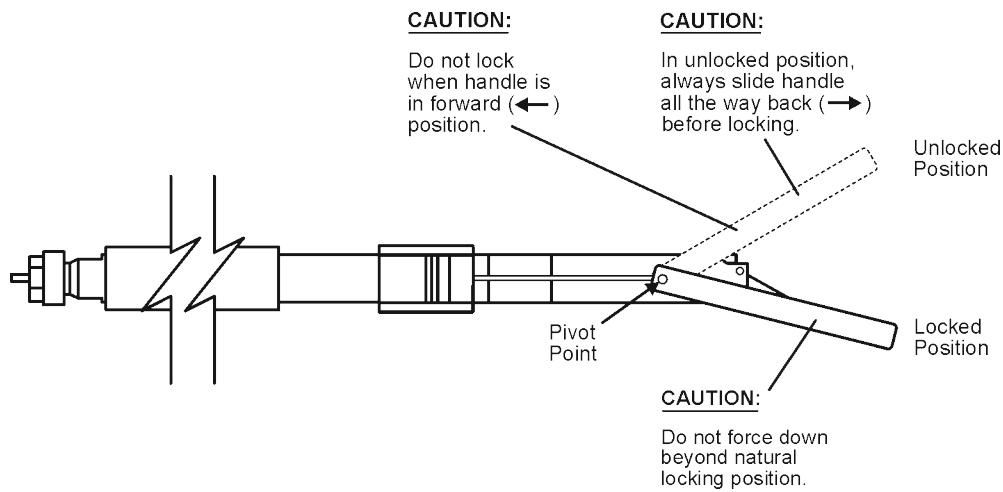

ph73a

How to Separate a Connection

To avoid lateral (bending) force on the connector mating plane surfaces, always support the devices and connections.

CAUTION

Do **not** turn the device body. Only turn the connector nut. Damage to the center conductor can occur if the device body is twisted.

If disconnecting a sliding load, leave the center conductor pullback handle in the locked position.

1. Use an open-end wrench to prevent the device body from turning.
2. Use another open-end wrench to loosen the connecting nut.
3. Complete the separation by hand, turning only the connecting nut.
4. Pull the connectors straight apart without twisting, rocking, or bending either of the connectors.

Using the Sliding Load

When performing a sliding load calibration, it is recommended that the sliding ring be set at the marked positions (rings) along the sliding load body. Using the set marks ensures that a broad distribution of phase angles is selected, thereby optimizing the calibration.

The set marks function as detents so that the internal center of the sliding ring can mate with them. Because of this, the set mark being used cannot be seen but is felt as the sliding ring is moved from mark to mark during a calibration. Moving the sliding ring with only the index fingers of both hands will increase your ability to detect the sliding ring detent at each position.

NOTE

The sliding load uses a plastic bead to support its center conductor when it is stored. Remove this support bead from the sliding load before you connect the load for use. Reinsert this support bead when you are finished using the sliding load.

Preferred Method:

1. Move the sliding ring forward as far as possible toward the connector end of the load.
2. Move the sliding ring back until you feel it detent at the first set mark.
3. Follow the network analyzer instructions to measure the sliding load at each detent position.

NOTE

After a calibration has begun, always move the sliding ring toward the center conductor pullback end of the sliding load. If you slightly overshoot the desired mark by less than 0.5 mm (0.02 inch), do not move the sliding ring, but continue with the calibration as if the sliding ring is set to the proper position. If the sliding ring is moved toward the connector end of the load during the calibration sequence, the calibration may be unstable and poor measurements may result. If the desired position is overshoot by more than 0.5 mm (0.02 inch), restart the calibration sequence from step 1.

It does not matter if you start with the slide at the front and move it backwards, or start at the back and move it forward. To minimize stability errors, it is important to start at one end and move it in the same direction for each of the measurement steps.

This manual contains limited information about a sliding load calibration. For detailed information on this calibration using a VNA, ENA or PNA series network analyzer, refer to the appropriate user guide or online Help.

- To view the ENA or PNA online Help, press the Help key on the front panel of the network analyzer.
- To view an online VNA user guide, use the following steps:

1. Go to www.keysight.com.
2. Enter your VNA model number (Ex: N5242A) in the Search box and click Search.
3. Under the heading Manuals & Guides, click on the title/hyperlink for the document PDF you want to view.

If you need additional information, see “[Where to Look for More Information](#)” on page 5-2.

Figure 3-8 Sliding Load Set Marks

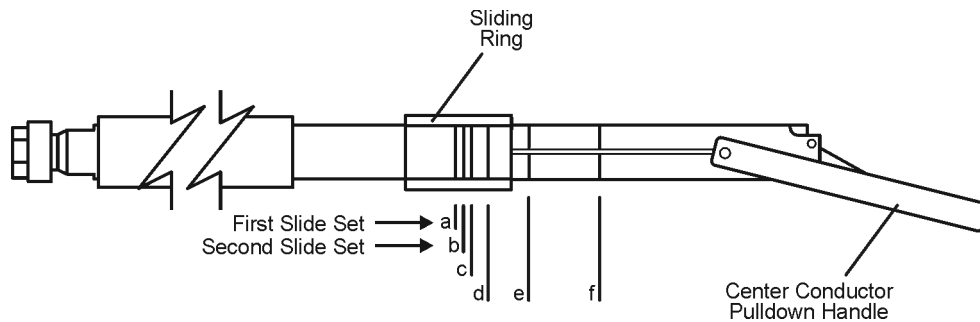

ph74a

Handling and Storage

- **Do** install the protective end caps and store the calibration devices in the foam-lined storage case when not in use.
- **Do** keep connectors clean.
- **Do not** touch mating plane surfaces. Natural skin oils and microscopic particles of dirt are easily transferred to a connector interface and are very difficult to remove.
- **Do not** set connectors contact-end down on a hard surface. The plating and the mating plane surfaces can be damaged if the interface comes in contact with any hard surface.
- **Do not** store connectors loose in a box, or in a desk or bench drawer. This is the most common cause of connector damage during storage.

4 Performance Verification

Introduction

The performance of your calibration kit can only be verified by returning the kit to Keysight Technologies for recertification. The equipment required to verify the specifications of the devices in the kit has been specially manufactured and is not commercially available.

How Keysight Verifies the Devices in Your Kit

Keysight verifies the specifications of these devices as follows:

- 1. The residual microwave error terms of the test system are verified with precision airlines and shorts that are directly traced to the National Institute of Standards and Technology (NIST). The airline and short characteristics are developed from mechanical measurements. The mechanical measurements and material properties are carefully modeled to give very accurate electrical representation. The mechanical measurements are then traced to NIST through various plug and ring gages and other mechanical measurements.**
- 2. Each calibration device is electrically tested on this system. For the initial (before sale) testing of the calibration devices, Keysight includes the test measurement uncertainty as a guardband to guarantee each device meets the published specification. For recertifications (after sale), no guardband is used and the measured data is compared directly with the specification to determine the pass or fail status. The measurement uncertainty for each device is, however, recorded in the calibration report that accompanies recertified kits.**

These two steps establish a traceable link to NIST for Keysight to the extent allowed by the Institute's calibration facility. The specifications data provided for the devices in the kit is traceable to NIST through Keysight Technologies.

Recertification

The following will be provided with a recertified kit:

- a new calibration sticker affixed to the case
- a certificate of calibration
- a calibration report for each device in the kit listing measured values, specifications, and uncertainties

Keysight Technologies may offer several different options of calibration standards compliance for your kit. For more information, contact Keysight Technologies. See [“Contacting Keysight” on page 5-3](#).

How Often to Recertify

The suggested initial interval for recertification is 12 months or sooner. The actual need for recertification depends on the use of the kit. After reviewing the results of the initial recertification, you may establish a different recertification interval that reflects the usage and wear of the kit.

NOTE

The recertification interval should begin on the date the kit is first used after the recertification date.

Where to Send a Kit for Recertification

Contact Keysight Technologies for information on where to send your kit for recertification. See [“Contacting Keysight” on page 5-3](#). Refer to [“Returning a Kit or Device to Keysight” on page 5-2](#) for details on sending your kit.

5 Troubleshooting

Troubleshooting Process

If you suspect a bad calibration, or if your network analyzer does not pass performance verification, follow the steps in [Figure 5-1](#).

Figure 5-1 Troubleshooting Flowchart

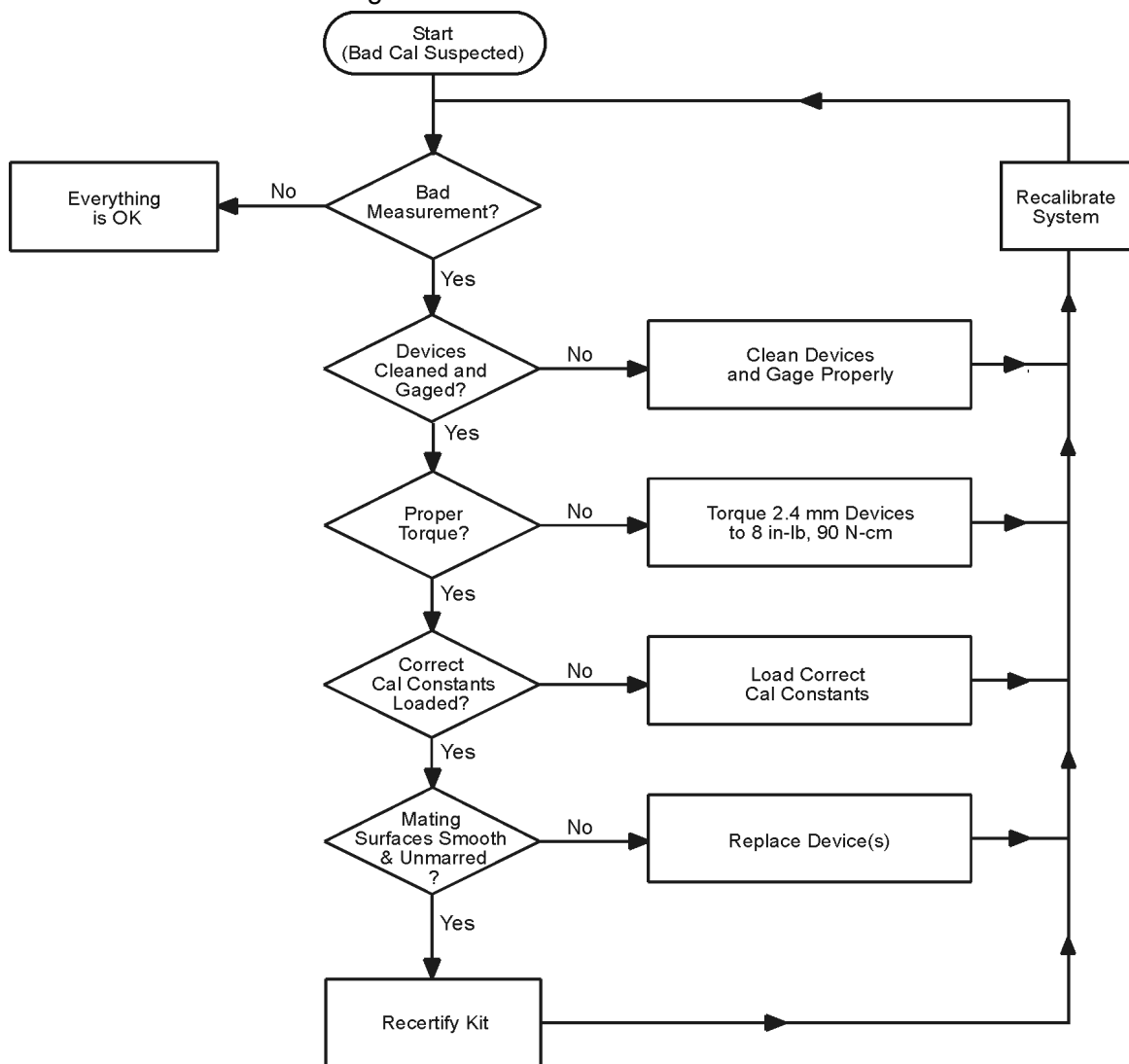

Where to Look for More Information

This manual contains limited information about network analyzer system operation. For detailed information on using an ENA or PNA series network analyzer, refer to the appropriate user guide or Help file.

- To view the ENA or PNA Help, press the Help key on the front panel of the network analyzer.
- To view Help or a user guide online, use the following steps:
 1. Go to www.keysight.com.
 2. Enter your analyzer model number (Ex: N5242B) in the Search box and click Search.
 3. Under the heading Manuals, click on the title/hyperlink for the document PDF you want to view.

If you need additional information, see [“Contacting Keysight” on page 5-3](#).

Returning a Kit or Device to Keysight

If your kit or device requires service, contact Keysight Technologies for information on where to send it. See [“Contacting Keysight” on page 5-3](#). Include a service tag (located near the end of this manual) on which you provide the following information:

- your company name and address
- a technical contact person within your company, and the person's complete phone number
- the model number and serial number of the kit
- the part number and serial number of each device
- the type of service required
- a **detailed** description of the problem and how the device was being used when the problem occurred (such as calibration or measurement)

Contacting Keysight

Assistance with test and measurements needs and information on finding a local Keysight office are available on the Web at:

www.keysight.com/find/assist

If you do not have access to the Internet, please contact your Keysight field engineer.

NOTE

In any correspondence or telephone conversation, refer to the Keysight product by its model number and full serial number. With this information, the Keysight representative can determine whether your product is still within its warranty period.

Troubleshooting
Contacting Keysight

6 Replaceable Parts

Introduction

Table 6-1 lists the replacement part numbers for items included in the 85056A calibration kit and **Figure 6-1** and **Figure 6-2** illustrate each of these items.

Table 6-2 lists the replacement part numbers for items not included in the calibration kit that are either required or recommended for successful operation of the kit.

To order a listed part, note the description, the part number, and the quantity desired. Telephone or send your order to Keysight Technologies— see **“Contacting Keysight” on page 5-3**.

Table 6-1 Replaceable Parts for the 85056A Calibration Kit^a

| Description | Qty per kit | Keysight Part Number |
|------------------------------|-------------|---|
| Calibration Devices (2.4 mm) | | |
| -m- broadband load | 1 | 00901-60013 00901-60003 ^b |
| -f- broadband load | 1 | 00901-60011 00901-60004 ^b |
| -m- sliding load | 1 | 00915-60003 |
| -f- sliding load | 1 | 00915-60004 |
| -m- offset open | 1 | 85056-60022 |
| -f- offset open | 1 | 85056-60023 |
| -m- offset short | 1 | 85056-60020 |
| -f- offset short | 1 | 85056-60021 |
| Adapters (2.4 mm) | | |
| -m- to male | 1 | 85056-60005 |
| -f- to female | 1 | 85056-60006 |
| -m- to female | 1 | 85056-60007 |

Table 6-1 **Replaceable Parts for the 85056A Calibration Kit^a**

| Description | Qty per kit | Keysight Part Number |
|--|-------------|----------------------|
| Connector Gages (2.4 mm) | | |
| -m- gage set (includes gage master) | 1 | 11752-60108 |
| -f- gage set (includes gage master) | 1 | 11752-60107 |
| Centering bead (for gaging the 2.4 mm sliding loads) | 1 | 85056-20001 |
| Calibration Kit Storage Case | | |
| Box (without foam pads) | 1 | 5180-8419 |
| Foam pad (for lid) | 1 | 5181-5542 |
| Foam pad (for lower case) | 1 | 85056-80009 |
| Wrenches | | |
| 5/16 in, 90 N-cm (8 in-lb) torque wrench | 1 | 8710-1765 |
| 7 mm open-end wrench | 1 | 8710-1761 |
| Miscellaneous Items | | |
| User's and service guide | 1 | 85056-90020 |

- a. See the **“Clarifying the Terminology of a Connector Interface” on page 1-6**
- b. Part numbers in italic typeface are for production assemblies and cannot be ordered by customers. Both the replacement part number and the production part number are interchangeable and have identical performance.

Table 6-2 **Items Not Included in the Calibration Kit**

| Description | Qty | Keysight Part Number |
|---|-----|----------------------|
| ESD Protection Devices | | |
| Grounding wrist strap | 1 | 9300-1367 |
| 5 ft grounding cord for wrist strap | 1 | 9300-0980 |
| 2 ft by 4 ft conductive table mat with 15 ft grounding wire | 1 | 9300-0797 |
| ESD heel strap | 1 | 9300-1308 |
| Connector Cleaning Supplies | | |
| Anhydrous isopropyl alcohol (>92% pure) ^a | -- | -- |
| Foam-tipped cleaning swabs | 100 | 9301-1243 |

- a. Keysight can no longer safely ship isopropyl alcohol, so customers should purchase it locally.

Figure 6-1 Replaceable Parts for the 85056A Calibration Kit

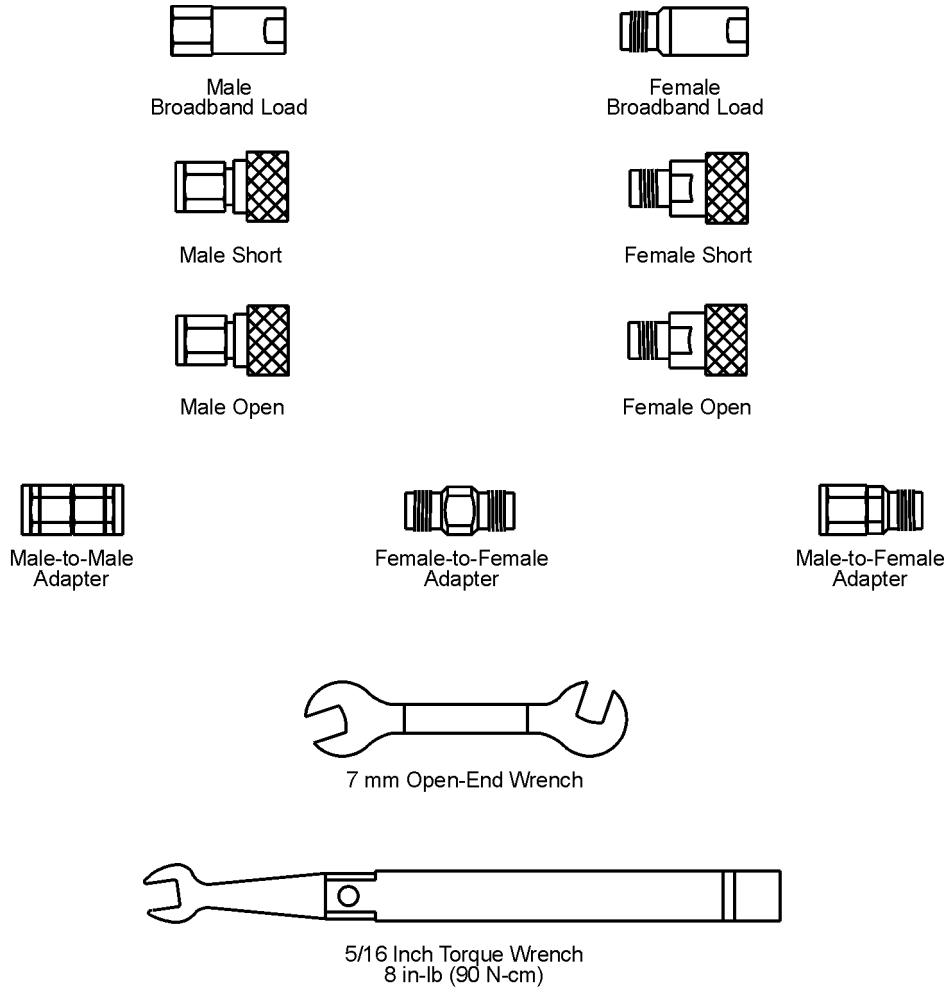

NOT SHOWN:

- User's and service guide
- Storage case

ph713a

Figure 6-2

Replaceable Parts for the 85056A Calibration Kit

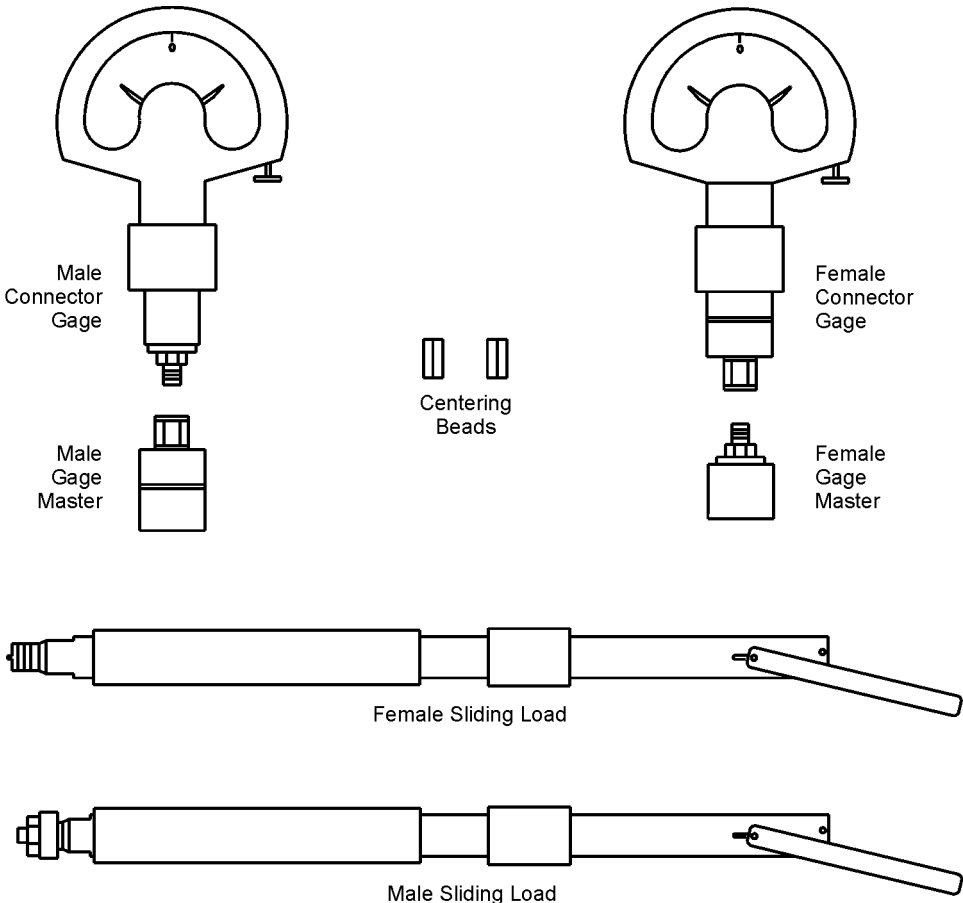

ph77a

A: Standard Definitions

Class Assignments and Standard Definitions Values are Available on the Web

Class assignments and standard definitions may change as more accurate model and calibration methods are developed. You can download the most accurate class assignments and standard definitions from Keysight's Calibration Kit Definitions Web page at <https://www.keysight.com/us/en/assets/9922-01521/technical-specifications/Calibration-Kit-Definitions.pdf>.

For a detailed discussion of calibration kits, refer to the Keysight Application Note, "Specifying Calibration Standards and Kits for Keysight Vector Network Analyzers." This application note covers calibration standard definitions, calibration kit content and its structure requirements for Keysight vector network analyzers. It also provides some examples of how to set up a new calibration kit and how to modify an existing calibration kit definition file. To download a free copy, go to www.keysight.com and enter literature number 5989-4840EN in the Search window.

Standard Definitions

Class Assignments and Standard Definitions Values are Available on the Web

Index

A

- adapters, 1-2
 - part numbers, 6-1
- alcohol
 - isopropyl
 - as cleaning solvent, 3-5
 - part number, 6-2
- antistatic mat
 - part number, 6-2

B

- box
 - pads
 - part numbers, 6-2
 - part number, 6-2
- broadband loads, 1-1
 - part numbers, 6-1
 - specifications, 2-4

C

- cal kit
 - performance
 - verifying, 4-1
- calibration
 - bad, 5-1
 - certificate of, 4-2
 - constants, *See* calibration definitions
 - frequency, 1-7
 - MIL-STD 45662, 4-2
 - report, 4-2
 - temperature, 2-1
 - when to perform, 1-7
- calibration definitions, 1-2
 - entering, 1-2
- calibration kit
 - contents, 1-1, 6-1
 - drawing of, 6-1
 - Keysight Application Note, A-1
 - modifying definition files, A-1
 - overview, 1-1
 - performance

how

- keysightverifies, 4-1
- verifying, 4-1
- care of connectors, 3-6
- case
 - part number, 6-2
- certificate of calibration, 4-2
- certification
 - of device specifications, 2-5
- characteristics
 - mechanical, 2-2
- class assignments
 - downloading from Keysight Web site, A-1
- cleaning connectors, 3-4
- cleaning supplies, 1-3
 - part numbers, 6-2
- cleaning swabs, 3-5
 - part number, 6-2
- compressed air
 - for cleaning, 3-4
- connections, 3-1, 3-16
 - ESD protection, 3-1, 3-16
 - final, 3-17
 - preliminary, 3-16
 - separating, 3-20
 - sliding load, 3-20
 - sliding load, 3-19
 - using torque wrench, 3-17
- connector
 - cleaning, 3-4
 - damage, 3-2
 - defects, 3-2
 - female, 3-3
- gage
 - accuracy, 3-8
 - handling, 3-8, 3-9, 3-12
 - part numbers, 6-2
 - use of, 3-8
 - zeroing, 3-8, 3-9, 3-12
- gaging, 3-8, 3-9
 - to determine pin depth, 3-8

when to do, 3-9

- mating plane surfaces, 3-5
 - cleaning, 3-5
- precision slotless (female), 1-5
- slotless, 3-3
- terminology, 1-6
- threads
 - cleaning, 3-5
 - inspecting, 3-2
 - visual inspection, 3-2
 - wear, 3-2
 - affect on electrical performance, 3-2

connectors

- care
 - principles of, 3-6
 - quick reference, 3-6
- care of, 3-6
- constants, calibration, *See* calibration definitions
- contacting Keysight Technologies, 5-2
- contents
 - calibration kit, 6-1
 - drawing of, 6-1
 - incomplete
 - what to do, 1-3

cord

- grounding
 - part number, 6-2

D

- damage
 - caused by electrostatic discharge, 3-1
 - device, 3-2
 - inspecting for, 3-2
 - to connectors, 3-2
 - what to do, 1-3
- damaged connectors, 3-2
- data
 - recertification, 4-2

defective connectors, 3-2
 defects
 connector, 3-2
 definitions
 calibration, 1-2
 entering, 1-2
 permanently stored, 1-2
 deviation from nominal
 phase, 2-4
 device
 connecting, 3-16
 damage, 3-2
 disconnecting, 3-20
 handling, 3-22
 maintenance, 1-6
 performance
 verifying, 4-1
 specifications, 2-4
 certification of, 2-5
 traceability, 4-1, 4-2
 storage, 3-22
 temperature, 2-1
 visual inspection, 3-2
 disconnections, 3-20
 downloading class
 assignments & std
 definitions from the
 Web, A-1

E

electrical characteristics
 effects of temperature, 2-1
 electrical specifications, 2-4
 electrostatic discharge, *See*
 ESD
 environmental
 requirements, 2-1
 specifications, 2-1
 equipment required, 1-3
 ESD, 3-1
 antistatic mat
 part number, 6-2
 heel strap
 part number, 6-2
 precautions, 3-4
 protection, 3-1
 supplies
 part numbers, 6-2
 wrist strap
 part number, 6-2

F

female connectors, 3-3
 inspection of, 3-3
 frequency
 specifications, 2-4
 frequency of calibration, 1-7

G

gage
 connector, 1-3
 handling, 3-9, 3-12
 part numbers, 6-2
 zeroing, 3-9, 3-12
 gaging
 connectors, 3-8, 3-9
 when to do, 3-9
 sliding loads, 3-12
 to determine pin depth, 3-8
 grounding cord
 part number, 6-2

H

handling, 3-22
 heel strap
 part number, 6-2
 how often to calibrate, 1-7
 humidity specifications, 2-1

I

incoming inspection, 1-3
 information,
 troubleshooting, 5-2
 inspection
 damage, 3-2
 defects, 3-2
 female connectors, 3-3
 incoming, 1-3
 mating plane surfaces, 3-3
 visual, 3-2
 isopropyl alcohol
 as cleaning solvent, 3-5

K

Keysight Technologies
 application note, A-1
 contacting, 5-2
 kit

contents, 1-1, 6-1
 drawing of, 6-1
 overview, 1-1

L

limits
 pin depth, 2-3
 loads
 broadband, 1-1
 part numbers, 6-1
 sliding, 1-2
 part numbers, 6-1

M

maintenance, 3-1
 of devices, 1-6
 preventive, 1-6
 making connections, 3-16
 ESD protection, 3-1, 3-16
 precautions, 3-16

mat

antistatic
 part number, 6-2
 conductive table
 part number, 6-2

mating plane surfaces

cleaning, 3-5
 connector, 3-5
 inspection of, 3-3
 mechanical characteristics, 2-2
 affect on electrical
 performance, 2-2
 verifying, 3-8

MIL-STD 45662

calibration, 4-2
 modifying calibration kit
 definition files, A-1

N

National Institute of Standards
 and Technology (NIST), 2-5,
 4-1
 nitrogen
 for cleaning, 3-4
 numbers
 replaceable parts, 6-1
 serial, 1-4
 recording, 1-4

O

- observed limits
 - pin depth, 2-3
- offset opens
 - part numbers, 6-1
- offset shorts
 - part numbers, 6-1
- offsets, 1-1
- open-end wrench, 1-1, 1-3, 3-20
 - 7-mm
 - part number, 6-2
- opens, 1-1
 - part numbers, 6-1
 - specifications, 2-4
- ordering
 - parts, 6-1

P

- pads
 - box
 - part numbers, 6-2
- part numbers, 6-1
 - of items in kit, 6-1
 - of items not in kit, 6-2
- parts
 - included in kit, 6-1
 - not included in kit, 6-1, 6-2
 - ordering, 6-1
 - replaceable, 6-1
- performance verification
 - fail, 5-1
- pin depth, 2-2
 - adjusting sliding load, 3-15
 - affect on electrical
 - performance, 2-3
 - gaging to determine, 3-8
 - observed limits, 2-3, 3-8
 - protrusion, 2-2
 - recession, 2-2
 - typical values, 2-3
- precision adapters
 - part numbers, 6-1
- precision slotless
 - connectors, 1-5
- preventive maintenance, 1-6
- protrusion
 - pin depth, 2-2

R

- recertification
 - how to order, 4-2
 - interval, 4-2
 - what's included, 4-2
 - where it's done, 4-2
- recession
 - pin depth, 2-2
- regulations
 - environmental, 2-1
- replaceable parts, 6-1
 - drawing of, 6-1
- report, calibration, 4-2
- requirements
 - environmental, 2-1
- return
 - kit or device to Keysight, 5-2
- return loss
 - specifications, 2-4

S

- separating connections, 3-20
- serial numbers, 1-4
 - devices, 1-4
 - recording, 1-4
- service, 5-2
- service tag, 1-3, 4-2, 5-2
- set marks
 - sliding load, 3-21
- shorts, 1-1
 - part numbers, 6-1
 - specifications, 2-4
- sliding load
 - calibration, 3-21
 - connecting, 3-19
 - pin depth
 - adjusting, 3-15
 - separating connection, 3-20
 - set marks, 3-21
 - sliding ring, 3-21
 - using, 3-21
- sliding loads, 1-2
 - gaging, 3-12
 - part numbers, 6-1
 - specifications, 2-4
- sliding ring
 - sliding load, 3-21
- specifications, 2-1
 - certification of, 2-5

- deviation from nominal
 - phase, 2-4

- device, 2-4
- electrical, 2-4
- environmental, 2-1
- frequency, 2-4
- humidity, 2-1
- return loss, 2-4
- temperature, 2-1
- torque wrench, 3-17
- traceability, 4-1, 4-2
- standard definitions
 - downloading from Keysight
 - Web site, A-1
- standards
 - international, 2-5
 - National Institute of Standards and Technology (NIST), 2-5, 4-1
- static
 - discharge, 3-1
 - electricity, 3-1
- storage, 3-22
- storage case
 - part number, 6-2
- strap
 - heel and wrist
 - part number, 6-2
- supplies, cleaning, 1-3
 - part number, 6-2
- swabs, cleaning, 3-5
 - part number, 6-2

T

- tag
 - service, 1-3, 4-2, 5-2
- temperature
 - affect on electrical
 - performance, 2-1
 - calibration, 2-1
 - cautions about, 2-1
 - changes in, 2-1
 - device, 2-1
 - error-corrected, 2-1
 - measurement, 2-1
 - specifications, 2-1
 - operating, 2-1
 - storage, 2-1
 - verification and
 - measurement, 2-1
- terminology, connector, 1-6

test data, 4-2

threads

connector

cleaning, 3-5

inspecting, 3-2

tools

part numbers, 6-2

torque wrench, 1-3

part number, 6-2

specifications, 3-17

traceability

of device specifications, 4-1,
4-2

troubleshooting, 5-1

U

user's and service guide

part number, 6-2

V

verification

temperature, 2-1

visual inspection, 3-2

W

wear

connector, 3-2

affect on electrical
performance, 3-
2

when to calibrate, 1-7

wrench

7 mm open-end

part number, 6-2

open-end, 1-3, 3-18, 3-20

proper positioning of, 3-18

torque, 1-3, 3-17, 3-18

part number, 6-2

precautions for use
of, 3-18

proper use of, 3-18

wrist strap

part number, 6-2

Z

zeroing

connector gage, 3-9, 3-12

This information is subject to change without notice.
© Keysight Technologies 1996 - 2024
January 2024



85056-90020
www.keysight.com