Keysight 2-Port and 4-Port PNA Network Analyzer

N5221B 900 Hz to 13.5 GHz

N5222B 900 Hz to 26.5 GHz

(for synthesizer revision 7)

Documentation Warranty

THE MATERIAL CONTAINED IN THIS DOCUMENT IS PROVIDED "AS IS," AND IS SUBJECT TO BEING CHANGED, WITHOUT NOTICE, IN FUTURE EDITIONS. FURTHER, TO THE MAXIMUM EXTENT PERMITTED BY APPLICABLE LAW, KEYSIGHT DISCLAIMS ALL WARRANTIES, EITHER EXPRESS OR IMPLIED WITH REGARD TO THIS MANUAL AND ANY INFORMATION CONTAINED HEREIN, INCLUDING BUT NOT LIMITED TO THE IMPLIED WARRANTIES OF MERCHANTABILITY AND FITNESS FOR A PARTICULAR PURPOSE. KEYSIGHT SHALL NOT BE LIABLE FOR ERRORS OR FOR INCIDENTAL OR CONSEQUENTIAL DAMAGES IN CONNECTION WITH THE FURNISHING, USE, OR PERFORMANCE OF THIS DOCUMENT OR ANY INFORMATION CONTAINED HEREIN. SHOULD KEYSIGHT AND THE USER HAVE A SEPARATE WRITTEN AGREEMENT WITH WARRANTY TERMS COVERING THE MATERIAL IN THIS DOCUMENT THAT CONFLICT WITH THESE TERMS, THE WARRANTY TERMS IN THE SEPARATE AGREEMENT WILL CONTROL.

U.S. Government Rights

U.S. Government Rights. The Software is "commercial computer software," as defined by Federal Acquisition Regulation ("FAR") 2.101. Pursuant to FAR 12.212 and 27.405-3 and Department of Defense FAR Supplement ("DFARS") 227.7202, the U.S. government acquires commercial computer software under the same terms by which the software is customarily provided to the public. Accordingly, Keysight provides the Software to U.S. government customers under its standard commercial license, which is embodied in its End User License Agreement (EULA), a copy of which can be found at <http://www.keysight.com/find/sweula>. The license set forth in the EULA represents the exclusive authority by which the U.S. government may use, modify, distribute, or disclose the Software. The EULA and the license set forth therein, does not require or permit, among other things, that Keysight: (1) Furnish technical information related to commercial computer software or commercial computer software documentation that is not customarily provided to the public; or (2) Relinquish to, or otherwise provide, the government rights in excess of these rights customarily provided to the public to use, modify, reproduce, release, perform, display, or disclose commercial computer software or commercial computer software documentation. No additional government requirements beyond those set forth in the EULA shall apply, except to the extent that those terms, rights, or licenses are explicitly required from all providers of commercial computer software pursuant to the FAR and the DFARS and are set forth specifically in writing elsewhere in the EULA. Keysight shall be under no obligation to update, revise or otherwise modify the Software. With respect to any technical data as defined by FAR 2.101, pursuant to FAR 12.211 and 27.404.2 and DFARS 227.7102, the U.S. government acquires no greater than Limited Rights as defined in FAR 27.401 or DFAR 227.7103-5 (c), as applicable in any technical data.

Table of Contents

Documentation Warranty	3
U.S. Government Rights	3
Table 1. Low Frequency Extension (LFE) Options	8
Definitions.....	9
Dynamic Range.....	11
System Dynamic Range.....	12
Table 2. System Dynamic Range at Test Port (dB), Options 200 or 400	12
Table 3. System Dynamic Range at Test Port (dB), Options 201 or 401	12
Table 4. System Dynamic Range at Test Port (dB), Options 217 or 417	13
Table 5. System Dynamic Range at Test Port (dB), Options 219 or 419	13
Table 6. System Dynamic Range at Test Port (dB), Options 205 or 405	14
Table 7. System Dynamic Range at Test Port (dB), Options 220 or 420	14
Table 8. System Dynamic Range at Test Port (dB), All LFE Options (LFE Enabled)	15
Extended Dynamic Range	16
Table 9. Extended Dynamic Range at Direct Receiver Access Input (dB) - Typical	16
Table 10. Extended Dynamic Range at Direct Receiver Access Input (dB) - Typical	16
Receiver Dynamic Range	17
Table 11. Receiver Dynamic Range (dB), All Options	17
Table 12. Receiver Dynamic Range (dB), All Ports, All LFE Options (LFE Enabled)	17
Corrected System Performance, All Options	18
Table 13. N5221B and N5222B with 85052B Calibration Kit.....	18
Transmission Uncertainty, All Options	19
Reflection Uncertainty, All Options.....	19
Table 14. N5221B and N5222B with N4691B 2-Port Electronic Calibration Module.....	20
Transmission Uncertainty, All Options	20
Reflection Uncertainty, All Options.....	20
Table 15. N5221B and N5222B with N4691D 2-Port Electronic Calibration Module	21
Transmission Uncertainty, All Options	21
Reflection Uncertainty, All Options.....	21
Table 16. N5221B and N5222B with N4433A 4-Port Electronic Calibration Module.....	22
Transmission Uncertainty, All Options	23
Reflection Uncertainty, All Options.....	23
Table 17. N5221B and N5222B with 85052B Calibration Kit, All LFE Options (LFE Enabled)	24
Transmission Uncertainty, All LFE Options	24
Reflection Uncertainty, All LFE Options	24
Table 18. N5221B and N5222B with N4691D Calibration Kit, All LFE Options (LFE Enabled)	25

Transmission Uncertainty, All LFE Options	25
Reflection Uncertainty, All LFE Options	25
Uncorrected System Performance	26
Table 19. Error Terms (dB), All Ports, All Options - Specifications.....	26
Table 20. Error Terms (dB), All Ports, All LFE Options (LFE Enabled) - Specifications.....	26
Table 21. Error Terms (dB), All Ports, All Options - Typical.....	27
Table 22. Error Terms (dB), All Ports, All LFE Options (LFE Enabled)- Typical.....	27
Test Port Output.....	28
Table 23. Frequency Information, All Options.....	28
Table 24. Maximum Leveled Power (dBm) - Specification	28
Table 25. Maximum Leveled Power (dBm) - Typical	29
Table 26. Maximum Leveled Power (dBm) - Option 205, 405	29
Table 27. Maximum Leveled Power (dBm) - Option 220, 420	30
Table 28. Maximum Power (dBm), All Ports – All LFE Options (LFE Enabled).....	30
Table 29. Power Level Accuracy (dB) at Nominal Power ¹ , All Options	31
Table 30. Power Level Accuracy (dB), All Ports, All LFE Options (LFE Enabled).....	31
Table 31. Power Level Linearity ¹ (dB), All Options - Specification	31
Table 32. Power Level Linearity ¹ (dB), All Options - Specification	32
Table 33. Power Level Linearity ¹ (dB), All Ports, All LFE Options (LFE Enabled).....	32
Table 34. Power Sweep Range (dB) - Specification.....	32
Table 35. Power Sweep Range (dB), All Options - Typical	33
Table 36. Power Sweep Range (dB), Option 205, 405.....	33
Table 37. Power Sweep Range (dB), Option 220, 420.....	34
Table 38. Power Sweep Range (dB) –All LFE Options (LFE Enabled).....	34
Table 39. Nominal Power (Preset Power, dBm)	34
Table 40. Power Resolution and Maximum/Minimum Settable Power, All Ports ¹	35
Table 41. 2 nd and 3 rd Harmonics at Max Specified Power (dBc), All Options - Typical	35
Table 42. 2 nd and 3 rd Harmonics at Max Specified Power (dBc), All Ports, All LFE Options (LFE Enabled) - Typical	35
Table 43. Non-Harmonic Spurs ¹ at Nominal Power (dBc), All Options – Typical.....	36
Tracking Spurs (Linear Frequency Scale)	36
Tracking Spurs (Logarithmic Frequency Scale).....	37
Table 44. Phase Noise (dBc/Hz), All Options, with UNY, Port 1, 3 - Typical.....	37
Table 45. Phase Noise (dBc/Hz), All Options, with UNY, Port 2, 4 - Typical.....	37
Phase Noise with Option UNY	38
Table 46. Phase Noise (dBc/Hz), All LFE Options (LFE Enabled), with UNY, All Ports - Typical.....	38
Table 47. Phase Noise (dBc/Hz), All Options, without UNY, All Ports - Typical.....	38
Phase Noise, CW 10 GHz, with Option UNY and without Option UNY	39

Test Port Input.....	40
Table 48. Test Port Noise Floor (dBm) @ 10 Hz IFBW, All Options.....	40
Table 49. Noise Floor (dBm) @ 10 Hz IFBW, All LFE Options (LFE Enabled)	40
Table 50. Direct Receiver Access Input Noise Floor (dBm), Options 201, 205, 217, 219, 220, 401, 405, 417, 419, 420	41
Table 51. 0.1 dB Compression, Option 201, 217, 219, 220, 401, 417, 419, and All LFE Options - Typical	41
Table 52. 0.1 dB Compression, All Ports, All LFE Options (LFE Enabled) - Typical.....	42
Table 53. Compression - Specification	42
Table 54. Compression - Specification	42
Table 55. Compression, All Ports, All LFE Options (LFE Enabled) - Specification	43
Table 56. Trace Noise ¹ Magnitude (dB rms), All Options	43
Table 57. Trace Noise ¹ Magnitude (dB rms), All Ports, All LFE Options (LFE Enabled).....	43
Table 58. Trace Noise ¹ Phase (deg rms), All Options	44
Table 59. Trace Noise ¹ Phase (deg rms), All Ports, All LFE Options (LFE Enabled).....	44
Table 60. Reference Level Magnitude, All Options - Specification.....	44
Table 61. Stability ¹ , All Options - Typical	45
Table 62. Stability ¹ , All LFE Options (LFE Enabled) - Typical	45
Table 63. Damage Input Level, All Options - Specification.....	45
Phase Noise Measurement Performance (with S930317B phase noise measurement application)	46
Table 64. Absolute Phase Noise Sensitivity (dBc/Hz), in Best mode - Supplemental Performance Data	46
Table 65. Absolute AM Noise Sensitivity (dBc/Hz), in Best mode - Supplemental Performance Data	46
Absolute Phase Noise Sensitivity (dBc/Hz) - Supplemental Performance Data.....	47
Single-Channel Residual Noise Measurement	48
Table 66. Single-Channel Residual Phase Noise Sensitivity (dBc/Hz), with Option UNY in Best mode - Supplemental Performance Data.....	48
Table 67. Single-Channel Residual AM Noise Sensitivity (dBc/Hz), with Option UNY in Best mode - Supplemental Performance Data.....	48
Single-Channel Residual Phase Noise Sensitivity (dBc/Hz) - Supplemental Performance Data	49
Table 68. Single-Channel Residual Phase Noise Sensitivity (dBc/Hz), without Option UNY in Best mode - Supplemental Performance Data	50
Table 69. Single-Channel Residual AM Noise Sensitivity (dBc/Hz), without Option UNY in Best mode - Supplemental Performance Data.....	50
2-Channel Residual Noise Measurement for Non-Frequency Converting Devices.....	51
Table 70. 2-Channel Residual Phase Noise Sensitivity (dBc/Hz) in Best mode - Supplemental Performance Data	51
Table 71. 2-Channel Residual AM Noise Sensitivity (dBc/Hz) in Best mode - Supplemental Performance Data	51
2-Channel Residual Phase Noise Sensitivity (dBc/Hz) - Supplemental Performance Data	52
Dynamic Accuracy	53

Table 72. N5221B and N5222B Dynamic Accuracy - Specification	53
N5221B/22B Dynamic Accuracy, 900 Hz, All LFE Options (LFE Enabled) - Specification	53
N5221B/22B Dynamic Accuracy, 10 MHz, All LFE Options (LFE Enabled) - Specification	53
N5221B/22B Dynamic Accuracy, 100 MHz, All LFE Options (LFE Enabled) - Specification	54
N5221B/22B Dynamic Accuracy, 10 MHz to 50 MHz - Specification	54
N5221B/22B Dynamic Accuracy, 50 MHz to 500 MHz - Specification	54
N5221B/22B Dynamic Accuracy, 500 MHz to 1 GHz - Specification	55
N5221B/22B Dynamic Accuracy, 1 GHz to 2 GHz - Specification.....	55
N5221B/22B Dynamic Accuracy, 2 GHz to 20 GHz - Specification.....	55
N5221B/22B Dynamic Accuracy, 20 GHz to 26.5 GHz - Specification.....	56
Table 73. Group Delay ¹ - Typical.....	57
General Information	58
Table 74. Miscellaneous Information	58
Table 75. Front Panel Information, All Options	58
Table 76. Rear Panel Information, All Options.....	59
Table 77. Analyzer Dimensions and Weight	62
Regulatory and Environmental Information.....	62
Measurement Throughput Summary	64
Table 78. Cycle Time (ms) for Measurement Completion, All Models, All Options - Typical	64
Table 79. N5221B Cycle Time (ms) for Full-Span Measurement Completion - Typical	65
Table 80. N5222B Cycle Time (ms) for Full-Span Measurement Completion - Typical	65
Table 81. Cycle Time vs. IF Bandwidth - Typical.....	66
Table 82. Cycle Time (ms) vs. Number of Points - Typical.....	67
Table 83. Data Transfer Time ¹ (ms) - Typical	68
Front-Panel Jumpers.....	69
Table 84. Measurement Receiver Inputs (dBm) - Typical.....	69
Table 85. Reference Receiver Inputs and Reference Source Outputs (dBm) - Typical	69
Table 86. Reference Receiver Inputs and Reference Source Outputs (dBm) - Typical	70
Table 87. Source Outputs (dBm) - Typical.....	70
Table 88. Coupler Inputs (dB) - Typical	71
Table 89. Damage Level - Typical	71
Test Set Block Diagrams.....	72

This is a complete list of the technical specifications for the N5221B and N5222B PNA Series network analyzers with the following options (see block diagrams at the end of this document):

2-Port Models

Option 200 - 2-port base model with standard test set.

Option 201 - To base model, adds front-panel jumpers and R1 receiver switch.

Option 217 - To base model, adds front-panel jumpers, R1 receiver switch, and source and receiver attenuators (extended power range).

Option 219 - To base model, adds front-panel jumpers, R1 receiver switch, source and receiver attenuators (extended power range), and bias-tees.

4-Port Models

Option 400 - 4-port base model with standard test set.

Option 401 - To base model, adds front-panel jumpers and R1 receiver switch.

Option 417 - To base model, adds front-panel jumpers, R1 receiver switch, and source and receiver attenuators (extended power range).

Option 419 - To base model, adds front-panel jumpers, R1 receiver switch, source and receiver attenuators (extended power range), and bias-tees.

Table 1. Low Frequency Extension (LFE) Options

Option	Description
2-Port Models	
205	2-port standard test set (includes six front-panel access loops), R1 receiver switch, and low frequency extension (LFE) hardware.
220	2-port standard test set (includes six front-panel access loops), R1 receiver switch, source and receiver attenuators (extended power range), bias-tees, and low frequency extension (LFE) hardware.
4-Port Models	
405	4-port standard test set (includes six front-panel access loops), R1 receiver switch, and low frequency extension (LFE) hardware.
420	4-port standard test set (includes six front-panel access loops), R1 receiver switch, source and receiver attenuators (extended power range), bias-tees, and low frequency extension (LFE) hardware.

Notes

This document provides technical specifications for the 85052B calibration kit, N4691B ECal module, and N4433A ECal module.

Please download our free Uncertainty Calculator from http://www.keysight.com/find/na_calculator to generate the curves for your calibration kit and PNA setup.

For all tables in this document, the specified performance at the exact frequency of a break is the degraded value of the two specifications at that frequency.

Definitions

All specifications and characteristics apply over a 25 °C \pm 5 °C range (unless otherwise stated) and 90 minutes after the instrument has been turned on.

Specification (spec.): Warranted performance. Specifications include guardbands to account for the expected statistical performance distribution, measurement uncertainties, and changes in performance due to environmental conditions.

Characteristic (char.): A performance parameter that the product is expected to meet before it leaves the factory, but that is not verified in the field and is not covered by the product warranty. A characteristic includes the same guardbands as a specification.

Typical (typ.): Expected performance of an average unit which does not include guardbands. It is not covered by the product warranty.

Nominal (nom.): A general, descriptive term that does not imply a level of performance. It is not covered by the product warranty.

Supplemental performance data (SPD): A performance parameter that is tested on a minimal set of products during design validation. It does not include guardbands, and is not covered by the product warranty.

Calibration: The process of measuring known standards to characterize a network analyzer's systematic (repeatable) errors.

Corrected (residual): Indicates performance after error correction (calibration). It is determined by the quality of calibration standards and how well "known" they are, plus system repeatability, stability, and noise.

Uncorrected (raw): Indicates instrument performance without error correction. The uncorrected performance affects the stability of a calibration.

Standard: When referring to the analyzer, this includes no options unless noted otherwise.

Standard and LFE measurements: With an LFE option, which adds low frequency extension (LFE) hardware, the LFE measurement range overlaps with the standard measurement range from 10 MHz to 100 MHz. With LFE Enabled, measurements from 500 Hz to 100 MHz use LFE hardware. With LFE Disabled, measurements from 10 MHz to 100 MHz use standard hardware. To measure below 10 MHz, LFE must be enabled. All measurements above 100 MHz use standard hardware, regardless of the LFE Enabled/Disabled setting.

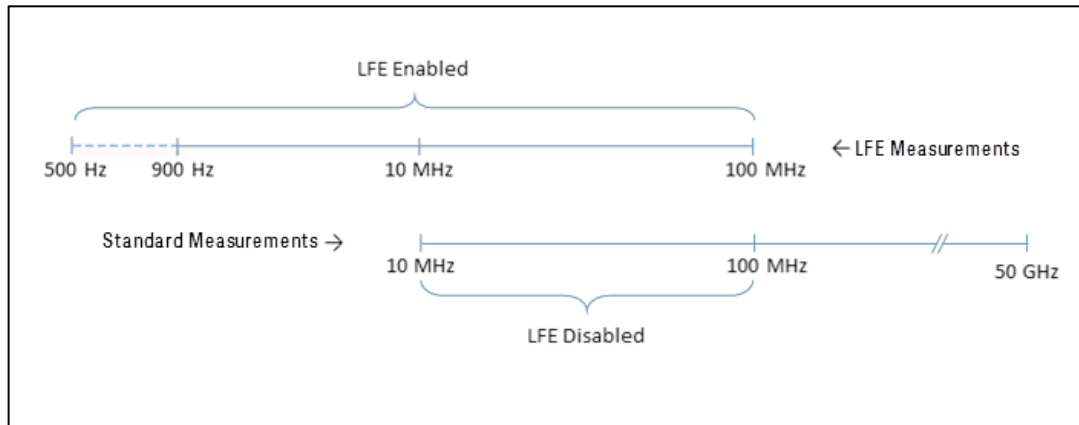

Dynamic Range

The specifications in this section apply for measurements made with the N5221B and N5222B PNA network analyzers with the following conditions:

- 10 Hz IF bandwidth
- No averaging applied to data
- Isolation calibration with an averaging factor of 8

System Dynamic Range is defined as the measured source maximum output power (A) minus the measured noise floor (B).

Extended Dynamic Range at Direct Access Input is defined as the system dynamic range (typical) less the nominal loss associated with the test port coupler.

Receiver Dynamic Range is defined as the typical test port 0.1 dB compression (C) minus the typical noise floor (D).

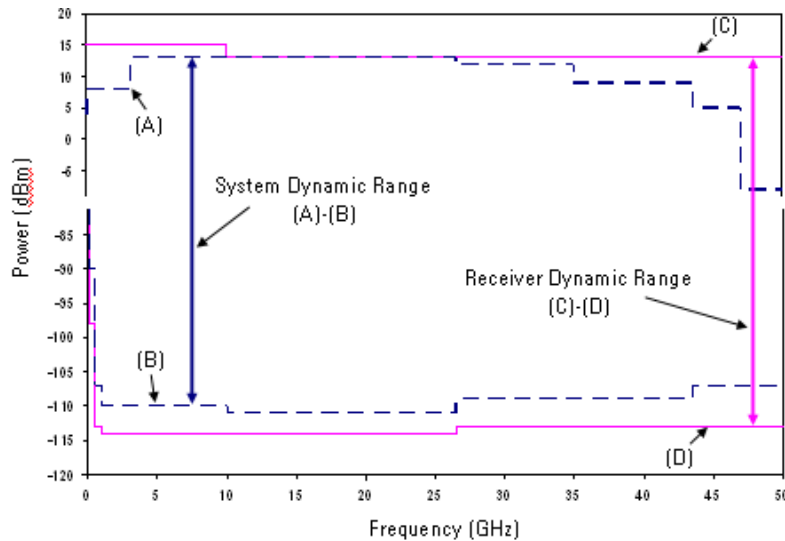

System Dynamic Range

Table 2. System Dynamic Range at Test Port (dB), Options 200 or 400

Description	Specification ¹		Typical	
	Ports ² 1, 3	Ports ² 2, 4	Ports ² 1, 3	Ports ² 2, 4
10 MHz to 50 MHz	102	100	109	107
50 MHz to 100 MHz	120	118	126	125
100 MHz to 500 MHz	126	129	136	136
500 MHz to 2 GHz	135	135	142	143
2 GHz to 3.2 GHz	132	133	140	141
3.2 GHz to 10 GHz	137	135	144	142
10 GHz to 13.5 GHz	136	134	143	141
13.5 GHz to 16 GHz	135	132	143	140
16 GHz to 20 GHz	134	130	142	137
20 GHz to 24 GHz	130	127	138	135
24 GHz to 26.5 GHz	128	123	138	133

¹ Specification applies to new instruments. Test limit during recertification is defined by Maximum Leveled Power - Noise Floor.

² Either port can be used as the source port. Any other port can be used as the receiver port.

Table 3. System Dynamic Range at Test Port (dB), Options 201 or 401

Description	Specification ¹		Typical (dB)	
	Ports ² 1, 3	Ports ² 2, 4	Ports ² 1, 3	Ports ² 2, 4
10 MHz to 50 MHz	102	99	109	107
50 MHz to 100 MHz	120	118	126	125
100 MHz to 500 MHz	126	124	136	135
500 MHz to 2 GHz	135	135	142	143
2 GHz to 3.2 GHz	132	134	140	141
3.2 GHz to 10 GHz	136	134	143	141
10 GHz to 13.5 GHz	135	132	143	140
13.5 GHz to 16 GHz	134	131	142	139
16 GHz to 20 GHz	133	129	141	136
20 GHz to 24 GHz	128	126	137	134
24 GHz to 26.5 GHz	127	122	137	132

¹ Specification applies to new instruments. Test limit during recertification is defined by Maximum Leveled Power - Noise Floor.

² Either port can be used as the source port. Any other port can be used as the receiver port.

Table 4. System Dynamic Range at Test Port (dB), Options 217 or 417

Description	Specification ¹		Typical (dB)	
	Ports ² 1, 3	Ports ² 2, 4	Ports ² 1, 3	Ports ² 2, 4
10 MHz to 50 MHz	103	100	109	107
50 MHz to 100 MHz	120	118	126	125
100 MHz to 500 MHz	126	125	136	135
500 MHz to 2 GHz	135	136	142	143
2 GHz to 3.2 GHz	133	135	140	142
3.2 GHz to 10 GHz	134	133	142	141
10 GHz to 13.5 GHz	133	131	142	139
13.5 GHz to 16 GHz	132	131	141	139
16 GHz to 20 GHz	134	130	142	137
20 GHz to 24 GHz	129	126	137	133
24 GHz to 26.5 GHz	124	118	134	128

¹ Specification applies to new instruments. Test limit during recertification is defined by Maximum Leveled Power - Noise Floor.

² Either port can be used as the source port. Any other port can be used as the receiver port.

Table 5. System Dynamic Range at Test Port (dB), Options 219 or 419

Description	Specification ¹		Typical (dB)	
	Ports ² 1, 3	Ports ² 2, 4	Ports ² 1, 3	Ports ² 2, 4
10 MHz to 50 MHz	101	99	108	106
50 MHz to 100 MHz	118	117	125	124
100 MHz to 500 MHz	124	124	135	135
500 MHz to 2 GHz	135	134	141	141
2 GHz to 3.2 GHz	133	134	140	141
3.2 GHz to 10 GHz	135	133	143	141
10 GHz to 13.5 GHz	133	131	142	139
13.5 GHz to 16 GHz	133	130	141	138
16 GHz to 20 GHz	134	129	141	136
20 GHz to 24 GHz	128	125	136	133
24 GHz to 26.5 GHz	123	117	133	128

¹ Specification applies to new instruments. Test limit during recertification is defined by Maximum Leveled Power - Noise Floor.

² Either port can be used as the source port. Any other port can be used as the receiver port.

Table 6. System Dynamic Range at Test Port (dB), Options 205 or 405

Description	Specification ³		Typical (dB)	
	Ports ² 1, 3	Ports ² 2, 4	Ports ² 1, 3	Ports ² 2, 4
10 MHz to 50 MHz ¹	96	93	103	100
50 MHz to 100 MHz ¹	116	115	122	122
100 MHz to 500 MHz	125	121	132	132
500 MHz to 2 GHz	130	132	137	140
2 GHz to 3.2 GHz	130	131	139	139
3.2 GHz to 10 GHz	131	133	140	140
10 GHz to 13.5 GHz	131	131	140	139
13.5 GHz to 16 GHz	130	129	140	137
16 GHz to 20 GHz	130	128	139	135
20 GHz to 24 GHz	126	124	135	132
24 GHz to 26.5 GHz	126	121	135	130

¹ With Option 205, 405 installed and LFE disabled, applied to frequencies <= 100 MHz. Above 100 MHz, performance is the same for both LFE enabled or disabled.

² Either port can be used as the source port. Any other port can be used as the receiver port.

³ Specification applies to new instruments. Test limit during recertification is defined by Maximum Levelled Power - Noise Floor.

Table 7. System Dynamic Range at Test Port (dB), Options 220 or 420

Description	Specification ³		Typical (dB)	
	Ports ² 1, 3	Ports ² 2, 4	Ports ² 1, 3	Ports ² 2, 4
10 MHz to 50 MHz ¹	94	92	102	100
50 MHz to 100 MHz ¹	114	113	121	120
100 MHz to 500 MHz	120	120	131	131
500 MHz to 2 GHz	132	131	138	138
2 GHz to 3.2 GHz	130	131	137	138
3.2 GHz to 10 GHz	133	131	141	139
10 GHz to 13.5 GHz	131	129	140	137
13.5 GHz to 16 GHz	131	128	139	136
16 GHz to 20 GHz	132	127	139	134
20 GHz to 24 GHz	126	123	134	131
24 GHz to 26.5 GHz	121	115	131	126

¹ With Option 220, 420 installed and LFE disabled, applied to frequencies <= 100 MHz. Above 100 MHz, performance is the same for both LFE enabled or disabled.

³ Specification applies to new instruments. Test limit during recertification is defined by Maximum Levelled Power - Noise Floor.

Table 8. System Dynamic Range at Test Port (dB), All LFE Options (LFE Enabled)

Description	Specification ¹		Typical	
	Ports 1, 3	Ports 2, 4	Ports 1, 3	Ports 2, 4
500 Hz to 900 Hz	--	--	105	105
900 Hz to 1 kHz	100	102	109	110
1 kHz to 10 kHz	103	105	110	111
10 kHz to 100 kHz	113	115	120	121
100 kHz to 1 MHz	120	121	124	125
1 MHz to 5 MHz	121	122	126	127
5 MHz to 10 MHz	112	114	118	119
10 MHz to 50 MHz	110	112	116	117
50 MHz to 100 MHz	110	112	116	117

¹ Specification applies to new instruments. Test limit during recertification is defined by Maximum Leveled Power - Noise Floor.

Extended Dynamic Range

Table 9. Extended Dynamic Range at Direct Receiver Access Input (dB) - Typical

Description	Options 201, 401		Options 217, 417	
	Ports ¹ 1, 3	Ports ¹ 2, 4	Ports ¹ 1, 3	Ports ¹ 2, 4
10 MHz to 50 MHz	153	151	153	151
50 MHz to 100 MHz	152	151	152	151
100 MHz to 500 MHz	156	155	156	155
500 MHz to 2 GHz	157	158	157	158
2 GHz to 3.2 GHz	155	156	155	157
3.2 GHz to 10 GHz	158	156	157	156
10 GHz to 13.5 GHz	158	155	157	154
13.5 GHz to 16 GHz	157	154	156	154
16 GHz to 20 GHz	156	151	157	152
20 GHz to 24 GHz	152	149	152	148
24 GHz to 26.5 GHz	152	147	149	143

¹Either port can be used as the source port. Any other port can be used as the receiver port.

Table 10. Extended Dynamic Range at Direct Receiver Access Input (dB) - Typical

Description	Option 219, 419		Option 220, 420		Options 205, 405	
	Ports ¹ 1, 3	Ports ¹ 2, 4	Ports ¹ 1, 3	Ports ¹ 2, 4	Ports ¹ 1, 3	Ports ¹ 2, 4
10 MHz to 50 MHz	152	150	145	143	147	144
50 MHz to 100 MHz	151	150	147	146	148	148
100 MHz to 500 MHz	155	155	151	151	152	152
500 MHz to 2 GHz	156	156	153	153	152	155
2 GHz to 3.2 GHz	155	156	152	153	154	154
3.2 GHz to 10 GHz	158	156	156	154	155	155
10 GHz to 13.5 GHz	157	154	155	152	155	154
13.5 GHz to 16 GHz	156	153	154	151	155	152
16 GHz to 20 GHz	156	151	154	149	154	150
20 GHz to 24 GHz	151	148	149	146	150	147
24 GHz to 26.5 GHz	148	143	146	141	150	145

¹ Either port can be used as the source port. Any other port can be used as the receiver port.

Receiver Dynamic Range

Table 11. Receiver Dynamic Range (dB), All Options

Description	Typical
10 MHz to 50 MHz ¹	103
50 MHz to 100 MHz ¹	118
100 MHz to 500 MHz	122
500 MHz to 2 GHz	130
2 GHz to 13.5 GHz	131
13.5 GHz to 20 GHz	132
20 GHz to 24 GHz	128
24 GHz to 26.5 GHz	126

¹ With an LFE option installed and LFE disabled, applied to frequencies \leq 100 MHz. Above 100 MHz, performance is the same for both LFE enabled or disabled.

Table 12. Receiver Dynamic Range (dB), All Ports, All LFE Options (LFE Enabled)

Description	Typical
500 Hz to 900 Hz	106
900 Hz to 1 kHz	109
1 kHz to 10 kHz	109
10 kHz to 100 kHz	118
100 kHz to 1 MHz	123
1 MHz to 5 MHz	123
5 MHz to 10 MHz	119
10 MHz to 50 MHz	120
50 MHz to 100 MHz	120

Corrected System Performance, All Options

Applies to the N5221B/2B Option 200, 201, 205, 217, 219, 220, 400, 401, 405, 417, 419, or 420 analyzers, 85131F flexible test port cable set, and a full 2-port calibration. Specifications are valid for temperatures of $23^{\circ}\pm 3^{\circ}\text{C}$ and $< 1^{\circ}\text{C}$ deviation from the calibration temperature.

For any S_{ii} reflection measurement:

- $S_{jj} = 0$.

For any S_{ij} transmission measurement:

- $S_{ji} = S_{ij}$ when $S_{ij} \leq 1$
- $S_{ji} = 1/S_{ij}$ when $S_{ij} > 1$
- $S_{kk} = 0$ for all k

Please download our free Uncertainty Calculator from http://www.keysight.com/find/na_calculator for specifications for other calibration kits and measurement setups.

Table 13. N5221B and N5222B with 85052B Calibration Kit

Description	Specification (dB)					
	10 MHz to 50 MHz ¹	50 MHz to 500 MHz ¹	500 MHz to 2 GHz	2 GHz to 13.5 GHz	13.5 GHz to 20 GHz	20 GHz to 26.5 GHz
Directivity	48	48	48	44	44	44
Source Match	40	40	40	31	31	31
Load Match	48	48	48	44	44	44
Reflection Tracking						
Mag	± 0.003	± 0.003	± 0.003	± 0.006	± 0.006	± 0.006
Phase (°)	± 0.020	± 0.020	± 0.020	± 0.040	± 0.040	± 0.040
Transmission Tracking						
Mag	± 0.034	± 0.017	± 0.017	± 0.091	± 0.104	± 0.119
Phase (°)	± 0.225	± 0.110	± 0.110	± 0.602	± 0.688	± 0.788

¹ With an LFE option installed and LFE disabled, applied to frequencies ≤ 100 MHz. Above 100 MHz, performance is the same for both LFE enabled or disabled.

Transmission Uncertainty, All Options

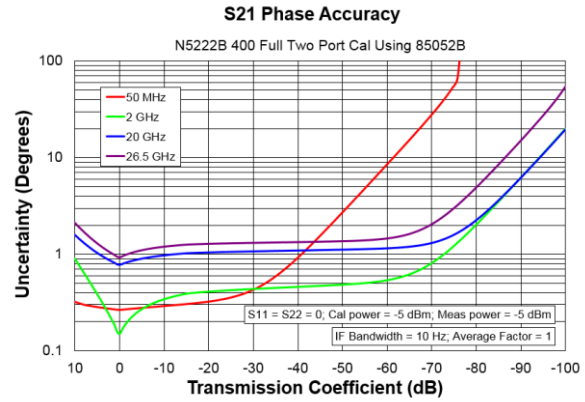
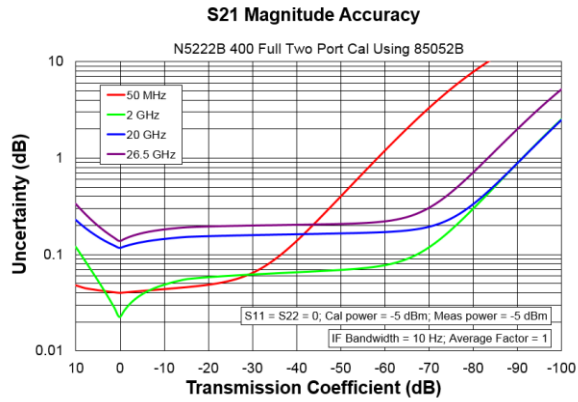

Reflection Uncertainty, All Options

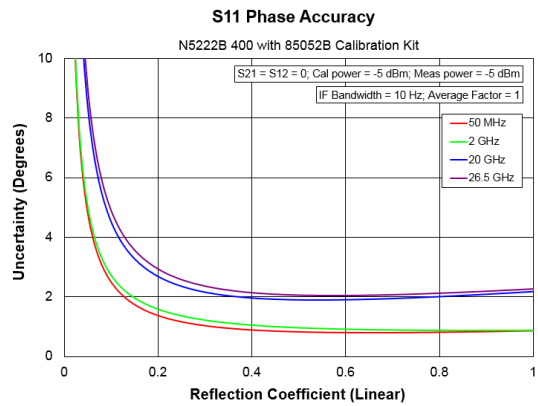
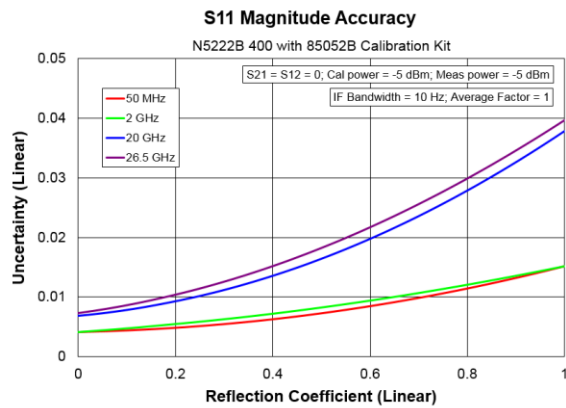
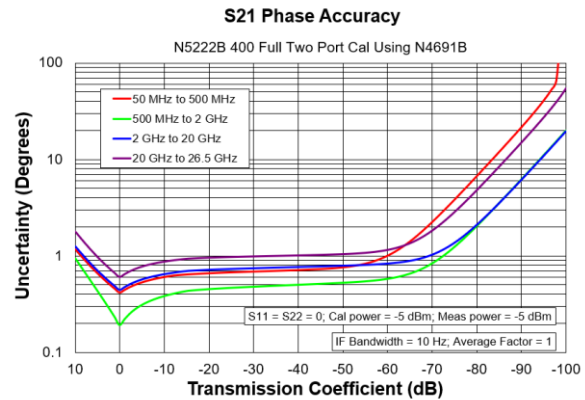
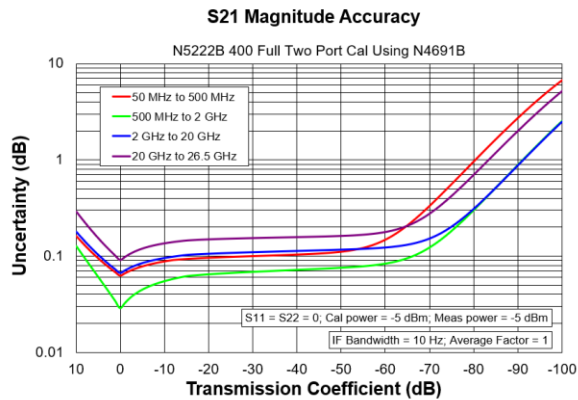

Table 14. N5221B and N5222B with N4691B 2-Port Electronic Calibration Module

Description	Specification (dB)					
	10 MHz to 50 MHz ¹	50 MHz to 500 MHz ¹	500 MHz to 2 GHz	2 GHz to 13.5 GHz	13.5 GHz to 20 GHz	20 GHz to 26.5 GHz
Directivity	46	46	52	46	46	44
Source Match	41	41	47	42	42	40
Load Match	39	40	46	40	40	38
Reflection Tracking						
Mag	±0.051	±0.051	±0.020	±0.041	±0.041	±0.051
Phase (°)	±0.34	±0.34	±0.14	±0.27	±0.27	±0.34
Transmission Tracking						
Mag	±0.063	±0.057	±0.024	±0.054	±0.056	±0.072
Phase (°)	±0.42	±0.38	±0.16	±0.36	±0.37	±0.48

¹ With an LFE option installed and LFE disabled, applied to frequencies ≤ 100 MHz. Above 100 MHz, performance is the same for both LFE enabled or disabled.

Transmission Uncertainty, All Options



Reflection Uncertainty, All Options

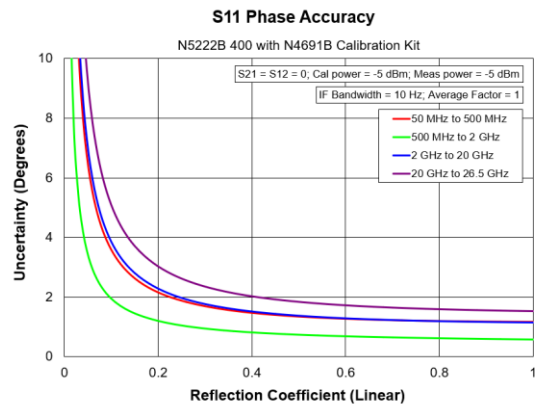
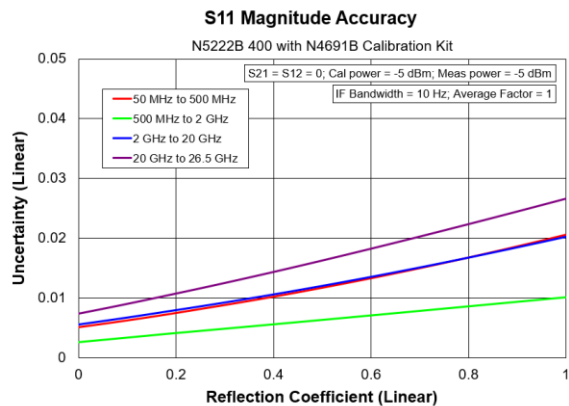
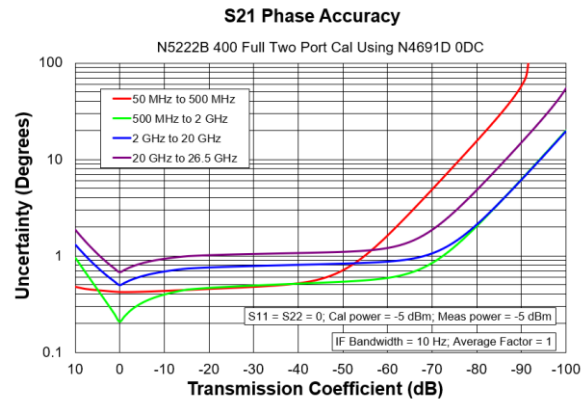
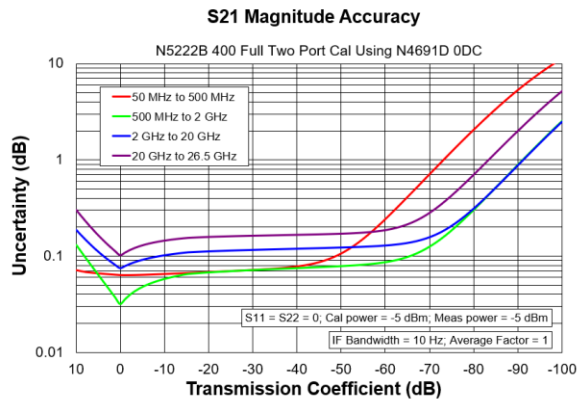

Table 15. N5221B and N5222B with N4691D 2-Port Electronic Calibration Module

Description	Specification (dB)					
	10 MHz to 50 MHz ¹	50 MHz to 500 MHz ¹	500 MHz to 2 GHz	2 GHz to 13.5 GHz	13.5 GHz to 20 GHz	20 GHz to 26.5 GHz
Directivity	46	46	47	43	43	41
Source Match	41	41	47	42	42	40
Load Match	39	40	46	40	40	38
Reflection Tracking						
Mag	±0.051	±0.051	±0.020	±0.041	±0.041	±0.051
Phase (°)	±0.34	±0.34	±0.14	±0.27	±0.27	±0.34
Transmission Tracking						
Mag	±0.063	±0.057	±0.026	±0.060	±0.062	±0.081
Phase (°)	±0.42	±0.38	±0.17	±0.40	±0.41	±0.54

¹ With an LFE option installed and LFE disabled, applied to frequencies ≤ 100 MHz. Above 100 MHz, performance is the same for both LFE enabled or disabled.

Transmission Uncertainty, All Options



Reflection Uncertainty, All Options

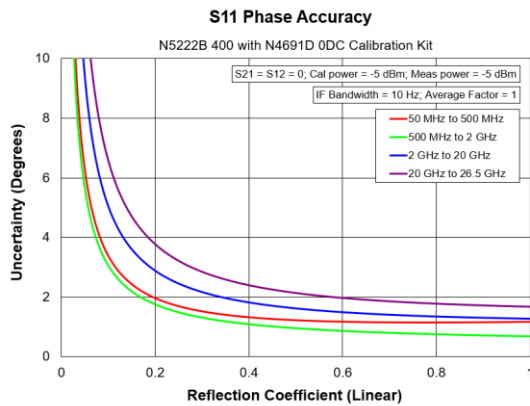
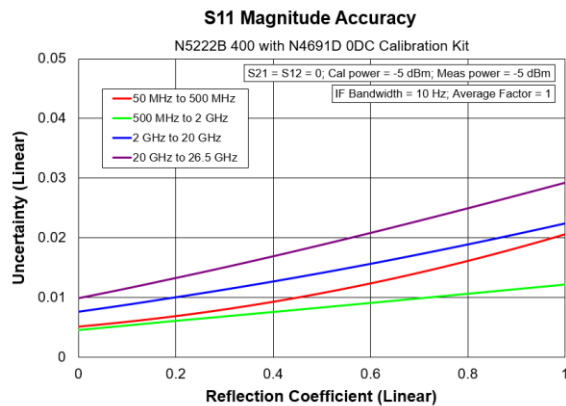

Table 16. N5221B and N5222B with N4433A 4-Port Electronic Calibration Module

NOTE

Uncertainty curves for the N4433A are created using a 2-port calibration. Multiport uncertainties are not supported at this time.

Description	Specification (dB)				
	10 MHz to 50 MHz ¹	50 MHz to 500 MHz ¹	500 MHz to 2 GHz	2 GHz to 13.5 GHz	13.5 GHz to 20 GHz
Directivity	50	50	50	45	40
Source Match	42	42	42	37	31
Load Match	40	41	41	35	29
Reflection Tracking					
Mag	±0.060	±0.060	±0.060	±0.100	±0.180
Phase (°)	±0.396	±0.396	±0.396	±0.660	±1.188
Transmission Tracking					
Mag	±0.068	±0.064	±0.064	±0.115	±0.210
Phase (°)	±0.447	±0.421	±0.421	±0.761	±1.387

¹ With an LFE option installed and LFE disabled, applied to frequencies ≤ 100 MHz. Above 100 MHz, performance is the same for both LFE enabled or disabled. For LFE enabled performance ≤ 100 MHz, see Table 17.

Transmission Uncertainty, All Options

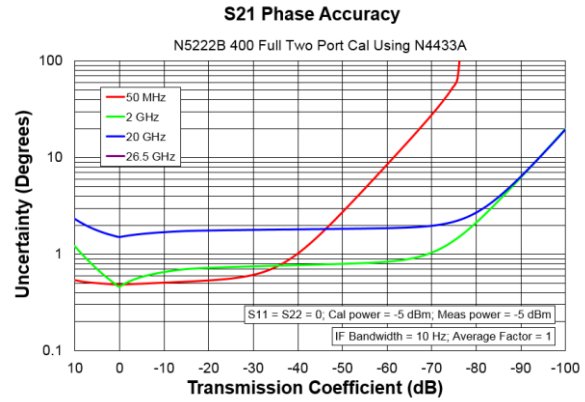
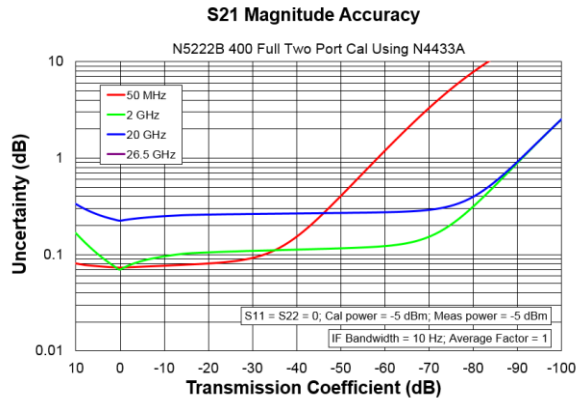

Reflection Uncertainty, All Options

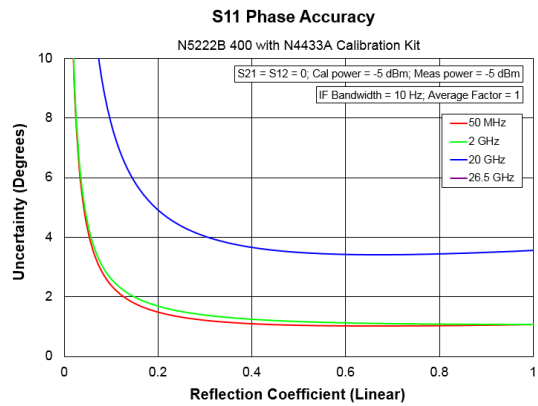
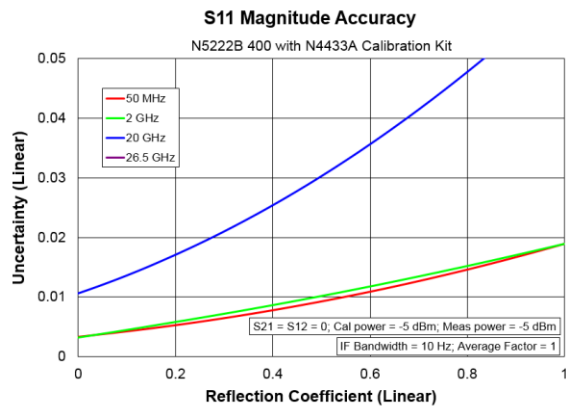
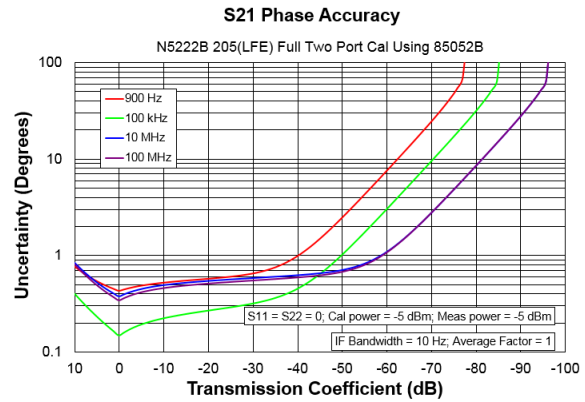
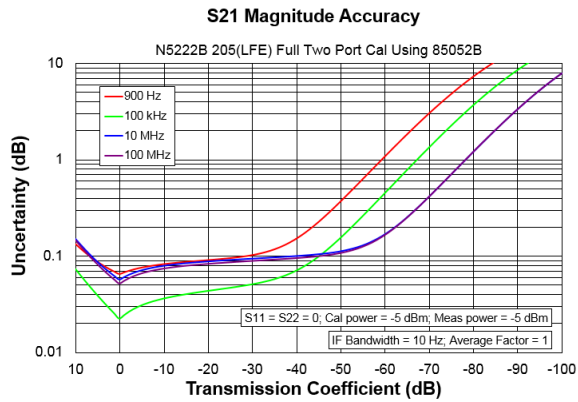

Table 17. N5221B and N5222B with 85052B Calibration Kit, All LFE Options (LFE Enabled)

Description	Specification (dB)				
	1 kHz to 10 kHz	10 kHz to 1 MHz	1 MHz to 5 MHz	5 MHz to 50 MHz	50 MHz to 100 MHz
Directivity	48	48	48	48	48
Source Match	40	40	40	40	40
Load Match	48	48	48	48	48
Reflection Tracking					
Mag	±0.003	±0.003	±0.003	±0.003	±0.003
Phase (°)	±0.020	±0.020	±0.020	±0.020	±0.020
Transmission Tracking					
Mag	±0.055	±0.016	±0.050	±0.045	±0.045
Phase (°)	±0.361	±0.105	±0.333	±0.296	±0.296

Transmission Uncertainty, All LFE Options

NOTE The plots are valid for all LFE options.



Reflection Uncertainty, All LFE Options

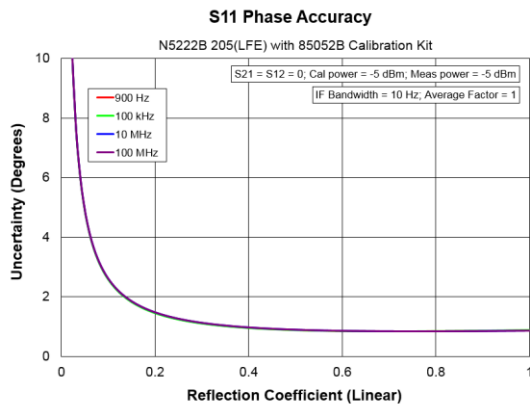
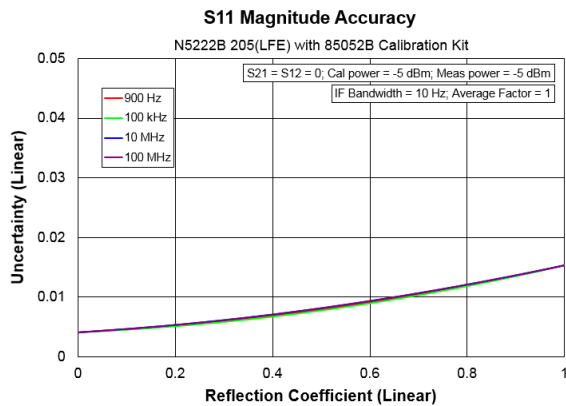
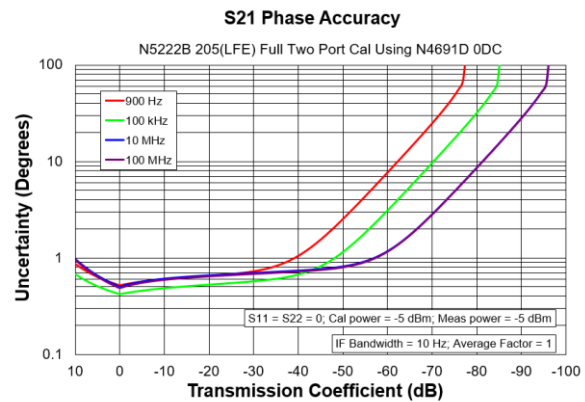
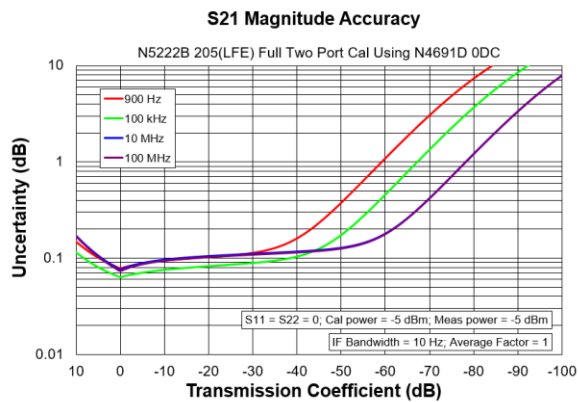

Table 18. N5221B and N5222B with N4691D Calibration Kit, All LFE Options (LFE Enabled)

Description	Specification (dB)				
	1 kHz to 10 kHz	10 kHz to 1 MHz	1 MHz to 5 MHz	5 MHz to 50 MHz	50 MHz to 100 MHz
Directivity	46	46	46	46	46
Source Match	41	41	41	41	41
Load Match	38	40	39	39	39
Reflection Tracking					
Mag	±0.051	±0.051	±0.051	±0.051	±0.051
Phase (°)	±0.34	±0.34	±0.34	±0.34	±0.34
Transmission Tracking					
Mag	±0.070	±0.055	±0.063	±0.068	±0.066
Phase (°)	±0.46	±0.37	±0.42	±0.45	±0.44

Transmission Uncertainty, All LFE Options

NOTE The plots are valid for all LFE options.



Reflection Uncertainty, All LFE Options

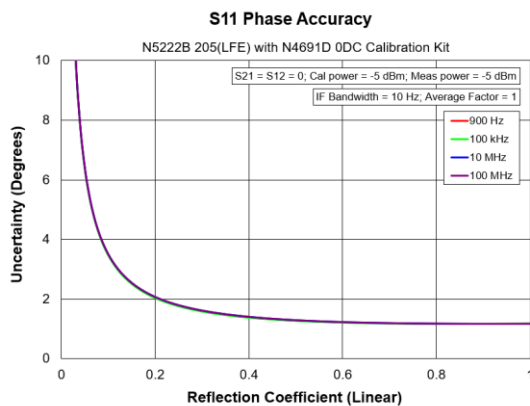
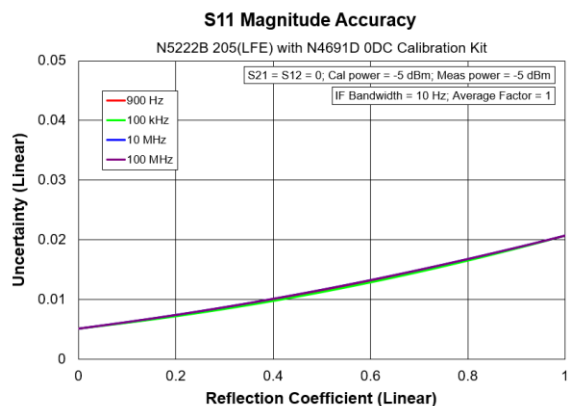

Uncorrected System Performance

Specifications apply to following conditions:

- Cable loss not included in Transmission Tracking.
- Crosstalk measurement conditions: normalized to a thru, measured with shorts on all ports, 10 Hz IF bandwidth, averaging factor of 8, alternate mode, source power set to the specified maximum power.

Table 19. Error Terms (dB), All Ports, All Options - Specifications

Description	Directivity	Source Match	Load Match	Transmission Tracking	Reflection Tracking	Crosstalk
10 MHz to 50 MHz ¹	16 (16) [16]	11 (9) [9]	11 (9) [9]	--	--	--
50 MHz to 3.2 GHz ¹	24 (24) [24]	18 (7) [7]	17 (7) [7]	--	--	--
3.2 GHz to 10 GHz	23 (22) [22]	14 (9) [9]	13 (9) [9]	--	--	--
10 GHz to 16 GHz	16 (16) [16]	12 (9) [9]	10 (9) [9]	--	--	--
16 GHz to 24 GHz	16 (16) [16]	10 (6) [6]	9 (7) [6]	--	--	--
24 GHz to 26.5 GHz	16 (16) [16]	8 (6) [6]	8 (6) [6]	--	--	--

() With option 205, 405 installed.

[] With option 220, 420 installed.

¹ With an LFE option installed and LFE disabled, applied to frequencies ≤ 100 MHz. Above 100 MHz, performance is the same for both LFE enabled or disabled. For LFE enabled performance ≤ 100 MHz, see Table 20.

Table 20. Error Terms (dB), All Ports, All LFE Options (LFE Enabled) - Specifications

Description	Directivity	Source Match	Load Match	Transmission Tracking	Reflection Tracking	Crosstalk
1 kHz to 10 kHz	1	7	7	--	--	--
10 kHz to 1 MHz	16	15	19	--	--	--
1 MHz to 5 MHz	16	9	11	--	--	--
5 MHz to 50 MHz	5	7	8	--	--	--
50 MHz to 100 MHz	5	8	9	--	--	--

Table 21. Error Terms (dB), All Ports, All Options - Typical

Description	Directivity	Source Match	Load Match	Transmission Tracking	Reflection Tracking	Crosstalk
10 MHz to 50 MHz ¹	23 (23)	17 (10)	16 (10)	±1.5	±1.5	-84
50 MHz to 100 MHz ¹	29 (29)	29 (11)	28 (11)	±1.5	±1.5	-90
100 MHz to 500 MHz	29 (29)	29 (8)	28 (8)	±1.5	±1.5	-110
500 MHz to 3.2 GHz	31 (31)	24 (8)	22 (8)	±1.5	±1.5	-120
3.2 GHz to 10 GHz	25 (25)	19 (14)	17 (14)	±1.5	±1.5	-122
10 GHz to 13.5 GHz	21 (21)	17 (13)	15 (13)	±1.5	±1.5	-122
13.5 GHz to 16 GHz	20 (20)	16 (16)	15 (14)	±1.5	±1.5	-122
16 GHz to 20 GHz	20 (20)	15 (12)	15 (12)	±1.5	±1.5	-122
20 GHz to 24 GHz	19 (19)	13 (11)	13 (11)	±1.5	±1.5	-117
24 GHz to 26.5 GHz	20 (20)	13 (10)	13 (11)	±1.5	±1.5	-114

() With an LFE option installed.

¹ With an LFE option installed and LFE disabled, applied to frequencies ≤ 100 MHz. Above 100 MHz, performance is the same for both LFE enabled or disabled. For LFE enabled performance ≤ 100 MHz, see Table 22.

Table 22. Error Terms (dB), All Ports, All LFE Options (LFE Enabled)- Typical

Description	Directivity	Source Match	Load Match	Transmission Tracking	Reflection Tracking	Crosstalk
500 Hz to 900 Hz	--	--	--	--	--	-102
900 Hz to 1 kHz	4	8	9	±1.5	±1.5	-106
1 kHz to 10 kHz	5	9	8	±1.5	±1.5	-100
10 kHz to 100 kHz	23	19	23	±1.5	±1.5	-106
100 kHz to 1 MHz	23	19	23	±1.5	±1.5	-126
1 MHz to 5 MHz	26	13	14	±1.5	±1.5	-121
5 MHz to 10 MHz	11	9	10	±1.5	±1.5	-121
10 MHz to 50 MHz	11	9	10	±1.5	±1.5	-117
50 MHz to 100 MHz	11	11	11	±1.5	±1.5	-117

Test Port Output

See the block diagrams at the end of this document for all models and options.

Table 23. Frequency Information, All Options

Description	Specification	Typical
N5221B Frequency Range	10 MHz to 13.5 GHz	--
N5222B Frequency Range	10 MHz to 26.5 GHz	--
N5221B Frequency Range (LFE Options)	900 Hz to 13.5 GHz	500 Hz to 900 Hz
N5222B Frequency Range (LFE Options)	900 Hz to 26.5 GHz	500 Hz to 900 Hz
Frequency Resolution	1 Hz	--
Frequency Accuracy	±0.7 ppm	--
Initial Frequency Accuracy ¹	±0.2 ppm	±0.1 ppm
Frequency Stability	--	±0.05 ppm, -10° to 70° C ² ±0.5 (first year) ³

¹ Verified after Factory Frequency Reference adjustment, or after adjustment at a Keysight Service Center.

² Assumes no variation in time.

³ Assumes no variation in temperature.

Table 24. Maximum Levelled Power (dBm) - Specification

Description	Option 200, 400, 201, 401		Option 217, 417, 219, 419	
	Ports 1, 3	Ports 2, 4	Ports 1, 3	Ports 2, 4
10 MHz to 50 MHz	12	12	12	12
50 MHz to 16 GHz	13	13	13	13
16 GHz to 20 GHz	13	12	10	10
20 GHz to 24 GHz	13	10	10	7
24 GHz to 26.5 GHz	7	5	4	2

Table 25. Maximum Levelled Power (dBm) - Typical

Description	Option 200, 400, 201, 401		Option 217, 417, 219, 419	
	Ports 1, 3	Ports 2, 4	Ports 1, 3	Ports 2, 4
10 MHz to 50 MHz	20	17	20	17
50 MHz to 500 MHz	20	18	20	18
500 MHz to 1 GHz	20	20	19	20
1 GHz to 3.2 GHz	19	20	19	20
3.2 GHz to 10 GHz	22	21	22	21
10 GHz to 13.5 GHz	22	19	21	18
13.5 GHz to 16 GHz	20	18	19	17
16 GHz to 20 GHz	20	16	18	14
20 GHz to 24 GHz	18	14	16	12
24 GHz to 26.5 GHz	14	11	12	9

Table 26. Maximum Levelled Power (dBm) - Option 205, 405

Description	Specification		Typical	
	Ports 1, 3	Ports 2, 4	Ports 1, 3	Ports 2, 4
10 MHz to 50 MHz ¹	5	5	13	10
50 MHz to 500 MHz ¹	8	8	15	13
500 MHz to 3.2 GHz	9	9	15	16
3.2 GHz to 10 GHz	11	11	20	19
10 GHz to 13.5 GHz	11	11	20	17
13.5 GHz to 16 GHz	10	10	17	15
16 GHz to 20 GHz	10	9	17	13
20 GHz to 24 GHz	10	7	15	11
24 GHz to 26.5 GHz	5	2	12	8

¹ With option 205, 405 installed and LFE disabled, applied to frequencies ≤ 100 MHz. Above 100 MHz, performance is the same for both LFE enabled or disabled. For LFE enabled performance ≤ 100 MHz, see Table 28.

Table 27. Maximum Leveled Power (dBm) - Option 220, 420

Description	Specification		Typical	
	Ports 1, 3	Ports 2, 4	Ports 1, 3	Ports 2, 4
10 MHz to 50 MHz ¹	5	5	13	10
50 MHz to 500 MHz ¹	9	9	16	14
500 MHz to 3.2 GHz	10	10	16	17
3.2 GHz to 10 GHz	11	11	20	19
10 GHz to 13.5 GHz	11	11	19	16
13.5 GHz to 16 GHz	11	11	17	15
16 GHz to 20 GHz	8	8	16	12
20 GHz to 24 GHz	8	5	14	10
24 GHz to 26.5 GHz	2	0	10	7

¹ With option 220, 420 installed and LFE disabled, applied to frequencies ≤ 100 MHz. Above 100 MHz, performance is the same for both LFE enabled or disabled. For LFE enabled performance ≤ 100 MHz, see Table 28.

Table 28. Maximum Power (dBm), All Ports – All LFE Options (LFE Enabled)

Description	Specification	Typical ¹
500 Hz to 900 Hz	--	12
900 Hz to 1 kHz	10	13
1 kHz to 10 kHz	12	13
10 kHz to 100 kHz	12	14
100 kHz to 1 MHz	12	14
1 MHz to 5 MHz	10	13
5 MHz to 10 MHz	9	11
10 MHz to 50 MHz	8	10
50 MHz to 100 MHz	8	10

¹ Values apply to all ports. Ports 2 and 4 typically 1 dB higher.

Table 29. Power Level Accuracy (dB) at Nominal Power¹, All Options

Description	Specification	Typical ¹
10 MHz to 50 MHz ²	±1.5	±0.5
50 MHz to 500 MHz ²	±1.0	±0.2
500 MHz to 3.2 GHz	±1.0	±0.1
3.2 GHz to 10 GHz	±1.0	±0.2
10 GHz to 13.5 GHz	±1.2	±0.2
13.5 GHz to 18 GHz	±2.0	±0.3
18 GHz to 26.5 GHz	±2.5	±0.4

¹ Level accuracy at power other than nominal power, Power Level Accuracy (dB) at Nominal Power + Power Level Linearity (dB)

² With an LFE option installed and LFE disabled, applied to frequencies ≤ 100 MHz. Above 100 MHz, performance is the same for both LFE enabled or disabled. For LFE enabled performance ≤ 100 MHz, see Table 30.

Table 30. Power Level Accuracy (dB), All Ports, All LFE Options (LFE Enabled)

Description	Specification	Typical ¹
500 Hz to 900 Hz	--	± 0.1
900 Hz to 1 kHz	± 1.0	± 0.1
1 kHz to 10 kHz	± 1.0	± 0.1
10 kHz to 100 kHz	± 1.0	± 0.1
100 kHz to 1 MHz	± 1.0	± 0.15
1 MHz to 5 MHz	± 1.0	± 0.15
5 MHz to 10 MHz	± 1.0	± 0.2
10 MHz to 50 MHz	± 1.0	± 0.2
50 MHz to 100 MHz	± 1.0	± 0.2

Table 31. Power Level Linearity¹ (dB), All Options - Specification

Description	Ports 1, 3 ² -25 dBm ≤ P < -20 dBm	Ports 1, 3 ² -20 dBm ≤ P < -15 dBm	Ports 1, 3 ² P ≥ -15 dBm
10 MHz to 50 MHz ³	±2.0	±1.5	±1.5
50 MHz to 26.5 GHz ³	±1.5	±1.5	±1.5

¹ Referenced to nominal power.

² Either port can be used as the source port.

³ With an LFE option installed and LFE disabled, applied to frequencies ≤ 100 MHz. Above 100 MHz, performance is the same for both LFE enabled or disabled. For LFE enabled performance ≤ 100 MHz, see Table 33.

Table 32. Power Level Linearity¹ (dB), All Options - Specification

Description	Ports 2, 4 ² -25 dBm ≤ P < -20 dBm	Ports 2, 4 ² -20 dBm ≤ P < -15 dBm	Ports 2, 4 ² P ≥ -15 dBm
10 MHz to 50 MHz ³	±2.5	±1.5	±1.5
50 MHz to 500 MHz ³	±2.0	±1.5	±1.5
500 MHz to 26.5 GHz	±1.5	±1.5	±1.5

¹ Referenced to nominal power.

² Either port can be used as the source port.

³ With an LFE option installed and LFE disabled, applied to frequencies ≤ 100 MHz. Above 100 MHz, performance is the same for both LFE enabled or disabled. For LFE enabled performance ≤ 100 MHz, see Table 33.

Table 33. Power Level Linearity¹ (dB), All Ports, All LFE Options (LFE Enabled)

Description	Specification
500 Hz to 900 Hz	--
900 Hz to 100 MHz	±1.0

¹ Referenced to nominal power, from -25 dBm to max power.

Table 34. Power Sweep Range (dB) - Specification

Description	Option 200, 400, 201, 401		Option 217, 417, 219, 419	
	Ports 1, 3	Ports 2, 4	Ports 1, 3	Ports 2, 4
10 MHz to 50 MHz	37	37	37	37
50 MHz to 16 GHz	38	38	38	38
16 GHz to 20 GHz	38	37	35	35
20 GHz to 24 GHz	38	35	35	32
24 GHz to 26.5 GHz	32	30	29	27

Table 35. Power Sweep Range (dB), All Options - Typical

Description	Option 200, 400, 201, 401		Option 217, 417, 219, 419	
	Ports 1, 3	Ports 2, 4	Ports 1, 3	Ports 2, 4
10 MHz to 50 MHz	47	44	47	44
50 MHz to 500 MHz	47	45	47	45
500 MHz to 1 GHz	47	47	46	47
1 GHz to 3.2 GHz	46	47	46	47
3.2 GHz to 10 GHz	49	48	49	48
10 GHz to 13.5 GHz	49	46	48	45
13.5 GHz to 16 GHz	47	45	46	44
16 GHz to 20 GHz	47	43	45	41
20 GHz to 24 GHz	45	41	43	39
24 GHz to 26.5 GHz	41	38	39	36

Table 36. Power Sweep Range (dB), Option 205, 405

Description	Specification		Typical	
	Ports 1, 3	Ports 2, 4	Ports 1, 3	Ports 2, 4
10 MHz to 50 MHz ¹	30	30	40	37
50 MHz to 500 MHz ¹	33	33	42	40
500 MHz to 3.2 GHz	34	34	42	43
3.2 GHz to 10 GHz	36	36	47	46
10 GHz to 13.5 GHz	36	36	47	44
13.5 GHz to 16 GHz	35	35	44	42
16 GHz to 20 GHz	35	34	44	40
20 GHz to 24 GHz	35	32	42	38
24 GHz to 26.5 GHz	30	27	39	35

¹ With Option 205, 405 installed and LFE disabled, applied to frequencies <= 100 MHz. Above 100 MHz, performance is the same for both LFE enabled or disabled. For LFE enabled performance <= 100 MHz, see Table 38.

Table 37. Power Sweep Range (dB), Option 220, 420

Description	Specification		Typical	
	Ports 1, 3	Ports 2, 4	Ports 1, 3	Ports 2, 4
10 MHz to 50 MHz ¹	30	30	38	35
50 MHz to 500 MHz ¹	34	34	41	39
500 MHz to 3.2 GHz	35	35	41	42
3.2 GHz to 10 GHz	36	36	45	44
10 GHz to 13.5 GHz	36	36	44	41
13.5 GHz to 16 GHz	36	36	42	40
16 GHz to 20 GHz	33	33	41	37
20 GHz to 24 GHz	33	30	39	35
24 GHz to 26.5 GHz	27	25	35	42

¹ With Option 220, 420 installed and LFE disabled, applied to frequencies <= 100 MHz. Above 100 MHz, performance is the same for both LFE enabled or disabled. For LFE enabled performance <= 100 MHz, see Table 38.

Table 38. Power Sweep Range (dB) –All LFE Options (LFE Enabled)

Description	Specification	Typical ¹
500 Hz to 900 Hz	--	39
900 Hz to 1 kHz	35	40
1 kHz to 10 kHz	37	40
10 kHz to 100 kHz	37	41
100 kHz to 1 MHz	37	41
1 MHz to 5 MHz	35	40
5 MHz to 10 MHz	34	38
10 MHz to 50 MHz	33	37
50 MHz to 100 MHz	33	37

Table 39. Nominal Power (Preset Power, dBm)

Description	Option 200, 201, 205, 400, 401, 405	Option 217, 219, 220, 417, 419, 420
Preset Power	0	-5

Table 40. Power Resolution and Maximum/Minimum Settable Power, All Ports¹

Description	Specification (dB)	Typical (dBm)
Power Resolution	0.01	--
Maximum Settable Power	--	30
Minimum Settable Power		
Option 200, 201, 205, 400, 401, 405	--	-30
Option 217, 219, 220, 417, 419, 420	--	-95

Table 41. 2nd and 3rd Harmonics at Max Specified Power (dBc), All Options - Typical

Listed frequency is fundamental frequency; test at max specified power.

Description	2nd Harmonic	3rd Harmonic
10 MHz to 50 MHz ¹	-16	-15
50 MHz to 2 GHz	-23	-17
2 GHz to 8.85 GHz	-17	-19
8.85 GHz to 13.25 GHz	-17	--

¹ With an LFE option installed and LFE disabled, applied to frequencies ≤ 100 MHz. Above 100 MHz, performance is the same for both LFE enabled or disabled. For LFE enabled performance ≤ 100 MHz, see Table 42.

Table 42. 2nd and 3rd Harmonics at Max Specified Power (dBc), All Ports, All LFE Options (LFE Enabled) - Typical

Listed frequency is fundamental frequency; test at max specified power.

Description	2nd Harmonic	3rd Harmonic
500 Hz to 900 Hz	-32	-31
900 Hz to 1 kHz	-22	-23
1 kHz to 10 kHz	-22	-23
10 kHz to 100 kHz	-22	-23
100 kHz to 1 MHz	-25	-22
1 MHz to 5 MHz	-28	-24
5 MHz to 10 MHz	-27	-22
10 MHz to 33 MHz	-28	-21
33 MHz to 50 MHz	-28	--

Table 43. Non-Harmonic Spurs¹ at Nominal Power (dBc), All Options – Typical

Listed frequency is Source CW frequency, tested at 0 dBm.

Description	Non-Harmonic	±600 MHz Tracking Spur
10 MHz to 1 GHz	-80	-80
1 GHz to 10 GHz	-85	-81
10 GHz to 20 GHz	-82	-75
20 GHz to 26.5 GHz	-80	-70

¹ Non-harmonic spurs are negligible with Option 425 installed and LFE enabled.

Tracking Spurs (Linear Frequency Scale)

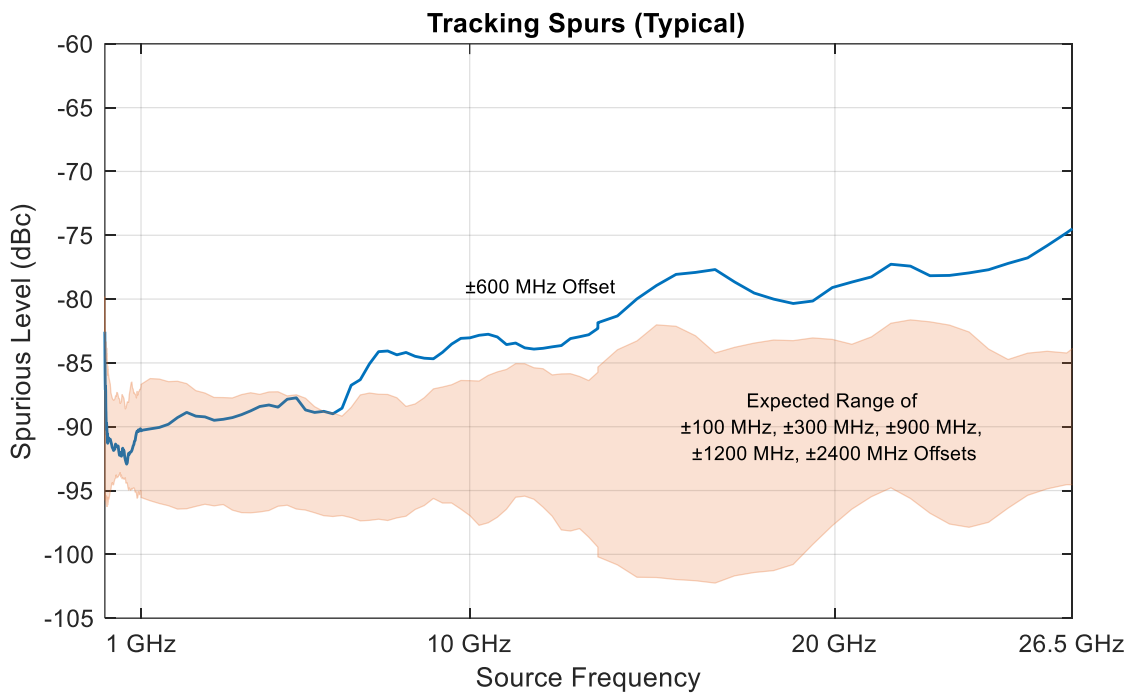

Tracking Spurs (Logarithmic Frequency Scale)

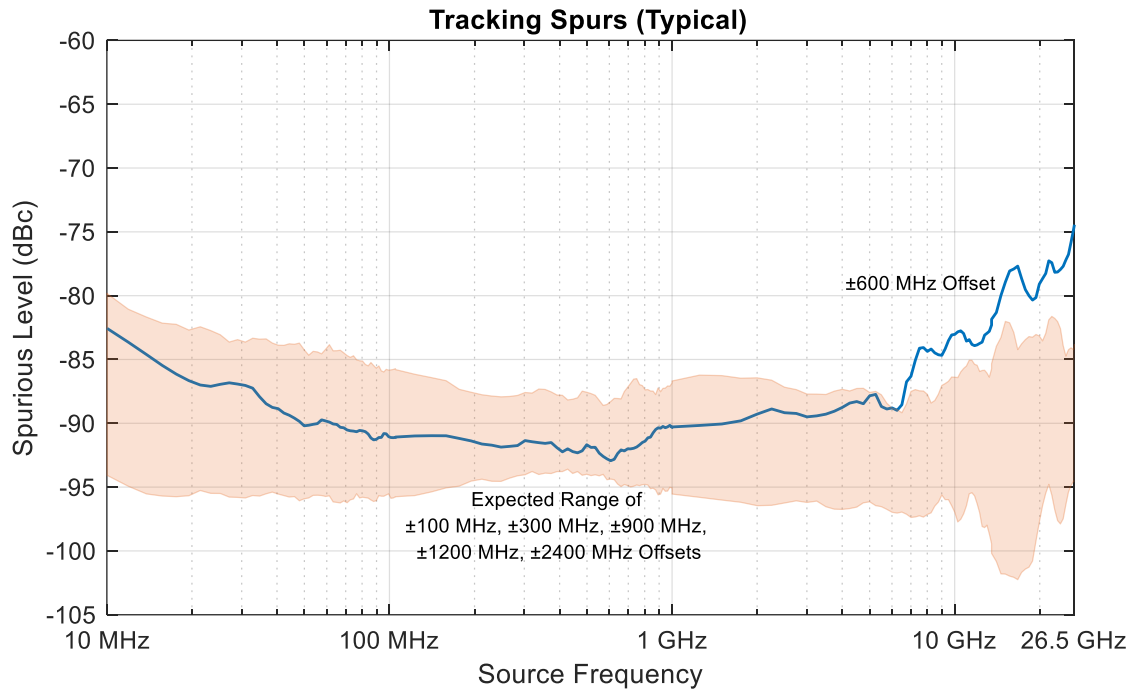

Table 44. Phase Noise (dBc/Hz), All Options, with UNY, Port 1, 3 - Typical

CW Frequency	100 Hz Offset	1 kHz Offset	10 kHz Offset	100 kHz Offset	1 MHz Offset	10 MHz Offset
1 GHz	-112	-132	-137	-143	-145	-144
5 GHz	-103	-123	-132	-135	-147	-150
10 GHz	-96	-116	-126	-130	-142	-146
20 GHz	-91	-111	-118	-123	-135	-139
26.5 GHz	-87	-106	-115	-121	-131	-135

Table 45. Phase Noise (dBc/Hz), All Options, with UNY, Port 2, 4 - Typical

CW Frequency	100 Hz Offset	1 kHz Offset	10 kHz Offset	100 kHz Offset	1 MHz Offset	10 MHz Offset
1 GHz	-111	-121	-132	-145	-149	-149
5 GHz	-103	-122	-128	-134	-145	-149
10 GHz	-96	-112	-120	-127	-140	-147
20 GHz	-90	-108	-116	-123	-134	-139
26.5 GHz	-86	-106	-114	-121	-131	-135

Phase Noise with Option UNY

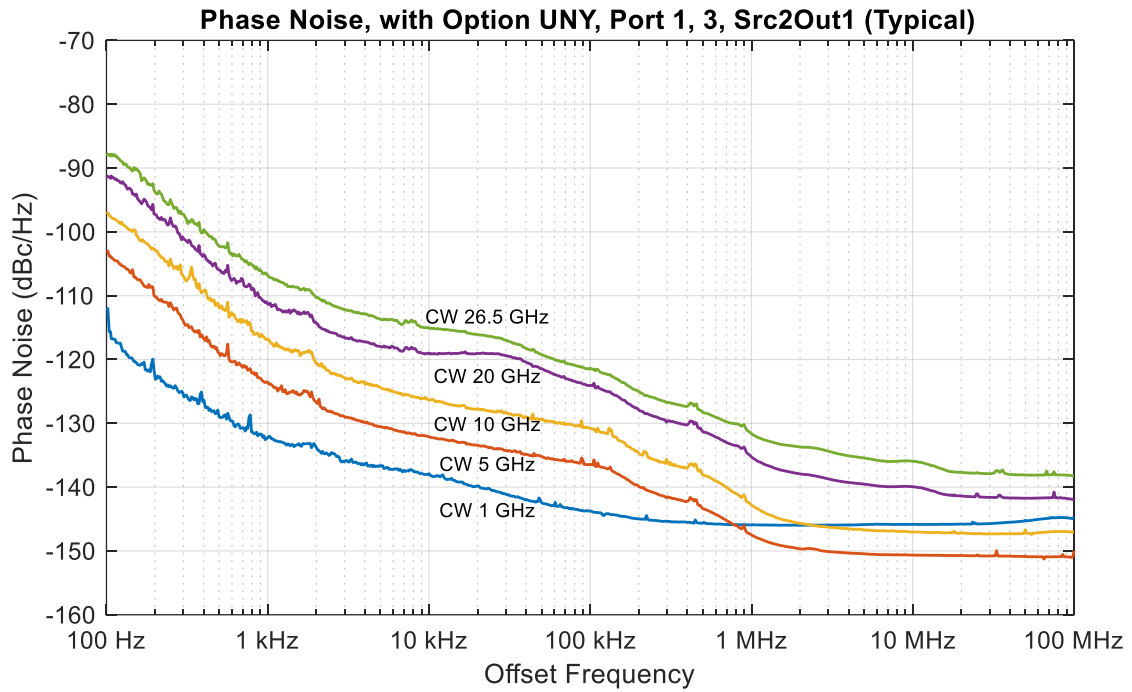

Table 46. Phase Noise (dBc/Hz), All LFE Options (LFE Enabled), with UNY, All Ports - Typical

Description	1 kHz Offset	10 kHz Offset	100 kHz Offset	1 MHz Offset
500 Hz to 100 MHz	-120	-130	-125	-135

Table 47. Phase Noise (dBc/Hz), All Options, without UNY, All Ports - Typical

CW Frequency	100 Hz Offset	1 kHz Offset	10 kHz Offset	100 kHz Offset	1 MHz Offset	10 MHz Offset
1 GHz	-94	-116	-130	-141	-145	-146
5 GHz	-83	-106	-119	-128	-139	-147
10 GHz	-78	-100	-113	-122	-133	-142
20 GHz	-72	-94	-107	-116	-127	-135
26.5 GHz	-67	-90	-104	-114	-124	-132

Phase Noise, CW 10 GHz, with Option UNY and without Option UNY

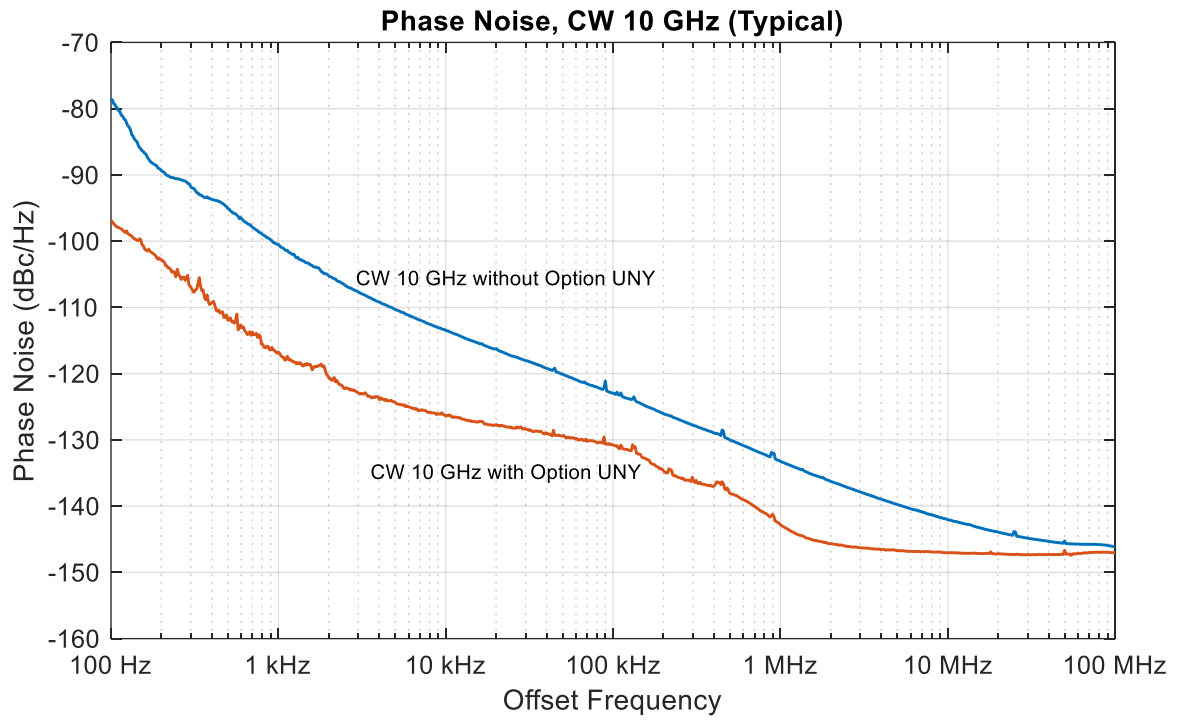

Test Port Input

Table 48. Test Port Noise Floor (dBm) @ 10 Hz IFBW, All Options

Total average (rms) noise power calculated as the mean value of a linear magnitude trace expressed in dBm.

May typically be degraded at particular frequencies below 500 MHz due to spurious receiver residuals.

Description	Specification		Typical	
	N5221B	N5222B	N5221B	N5222B
10 MHz to 50 MHz ¹	-82	-82	-88	-88
50 MHz to 100 MHz ¹	-95	-95	-103	-103
100 MHz to 500 MHz	-105	-105	-110	-110
500 MHz to 2 GHz	-114	-114	-118	-118
2 GHz to 13.5 GHz	-114	-114	-119	-119
13.5 GHz to 20 GHz	--	-114	--	-120
20 GHz to 24 GHz	--	-111	--	-118
24 GHz to 26.5 GHz	--	-107	--	-116

¹ With an LFE option installed and LFE disabled, applied to frequencies \leq 100 MHz. Above 100 MHz, performance is the same for both LFE enabled or disabled. For LFE enabled performance \leq 100 MHz, see Table 49.

Table 49. Noise Floor (dBm) @ 10 Hz IFBW, All LFE Options (LFE Enabled)

Description	Specification	Typical
500 Hz to 900 Hz	--	-93
900 Hz to 1 kHz	-90	-96
1 kHz to 10 kHz	-91	-96
10 kHz to 100 kHz	-101	-105
100 kHz to 1 MHz	-107	-110
1 MHz to 5 MHz	-108	-112
5 MHz to 10 MHz	-102	-106
10 MHz to 50 MHz	-102	-106
50 MHz to 100 MHz ¹	-102	-106

¹May be degraded at 100 MHz due to spurious receiver residuals.

Table 50. Direct Receiver Access Input Noise Floor (dBm), Options 201, 205, 217, 219, 220, 401, 405, 417, 419, 420

Total average (rms) noise power calculated as the mean value of a linear magnitude trace expressed in dBm.

May typically be degraded at particular frequencies below 500 MHz due to spurious receiver residuals.

Description	Specification		Typical	
	N5221B	N5222B	N5221B	N5222B
10 MHz to 50 MHz	-118	-118	-133	-133
50 MHz to 100 MHz	-107	-107	-129	-129
100 MHz to 250 MHz	-117	-117	-136	-136
250 MHz to 500 MHz	-117	-117	-130	-130
500 MHz to 2 GHz	-126	-126	-133	-133
2 GHz to 13.5 GHz	-126	-126	-134	-134
13.5 GHz to 20 GHz	--	-126	--	-135
20 GHz to 24 GHz	--	-123	--	-133
24 GHz to 26.5 GHz	--	-119	--	-131

Table 51. 0.1 dB Compression, Option 201, 217, 219, 220, 401, 417, 419, and All LFE Options - Typical

Description	N5221B	N5222B
	Test Port Power (dBm)	Test Port Power (dBm)
10 MHz to 100 MHz ¹	15	15
100 MHz to 13.5 GHz	12	12
13.5 GHz to 20 GHz	--	12
20 GHz to 26.5 GHz	--	10

¹ With an LFE option installed and LFE disabled, applied to frequencies ≤ 100 MHz. Above 100 MHz, performance is the same for both LFE enabled or disabled. For LFE enabled performance ≤ 100 MHz, see Table Table 52.

Table 52. 0.1 dB Compression, All Ports, All LFE Options (LFE Enabled) - Typical

Description	Test Port Power (dBm)
500 Hz to 900 Hz	13
900 Hz to 1 kHz	13
1 kHz to 10 kHz	13
10 kHz to 100 kHz	13
100 kHz to 1 MHz	13
1 MHz to 5 MHz	11
5 MHz to 10 MHz	13
10 MHz to 50 MHz	14
50 MHz to 100 MHz	14

Table 53. Compression - Specification

Description	Test Port Power (dBm)			Receiver Compression	
	Option 200, 400			Magnitude (dB)	Phase (degrees)
10 MHz to 500 MHz ¹	--			--	--
500 MHz to 16 GHz	8			0.21	1.60
16 GHz to 24 GHz	8			0.24	1.73
24 GHz to 26.5 GHz	8			0.42	2.51

¹ Test port receiver compression at specified input levels below 500 MHz due to coupler roll off in this frequency range.

Table 54. Compression - Specification

Description	Test Port Power (dBm)			Receiver Compression	
	Option 201, 205, 401	Option 217, 417	Option 219, 419	Magnitude (dB)	Phase (degrees)
10 MHz to 500 MHz ¹	--	--	--	--	--
500 MHz to 16 GHz	8	8	8	0.17	0.97
16 GHz to 24 GHz	8	8	8	0.23	1.20
24 GHz to 26.5 GHz	8	8	8	0.29	1.74

¹ Test port receiver compression at specified input levels below 500 MHz due to coupler roll off in this frequency range.

Table 55. Compression, All Ports, All LFE Options (LFE Enabled) - Specification

Description	Test Port Power (dBm)		
	Receiver Compression		
	All Options	Magnitude (dB)	Phase (degrees)
500 Hz to 900 Hz	--	--	--
900 Hz to 1 kHz	10	0.2	1
1 kHz to 10 kHz	12	0.2	1
10 kHz to 100 kHz	12	0.2	1
100 kHz to 1 MHz	12	0.2	1
1 MHz to 5 MHz	10	0.2	1
5 MHz to 10 MHz	9	0.2	1
10 MHz to 50 MHz	8	0.2	1
50 MHz to 100 MHz	8	0.2	1

Table 56. Trace Noise¹ Magnitude (dB rms), All Options

Description	Specification			
	Typical			
	1 kHz IFBW	1 kHz IFBW	100 kHz IFBW	600 kHz IFBW
10 MHz to 100 MHz ²	0.007	0.0036	0.053	0.103
100 MHz to 13.5 GHz ²	0.002	0.0005	0.004	0.010
13.5 GHz to 16 GHz	0.002	0.0003	0.003	0.007
16 GHz to 22.5 GHz	0.002	0.0005	0.003	0.007
22.5 GHz to 24 GHz	0.003	0.0008	0.004	0.011
24 GHz to 26.5 GHz	0.005	0.0012	0.007	0.017

¹ Ratioed measurement, nominal power at test port.

² With an LFE option installed and LFE disabled, applied to frequencies ≤ 100 MHz. Above 100 MHz, performance is the same for both LFE enabled or disabled. For LFE enabled performance ≤ 100 MHz, see Table 57.

Table 57. Trace Noise¹ Magnitude (dB rms), All Ports, All LFE Options (LFE Enabled)

Description	Specification		Typical			
	100 Hz IFBW	1 kHz IFBW	100 Hz IFBW	1 kHz IFBW	100 kHz IFBW	600 kHz IFBW
500 Hz to 900 Hz	--	--	0.002	--	--	--
900 Hz to 4 kHz	0.004	--	0.001	--	--	--
4 kHz to 300 kHz	--	0.004	--	0.002	--	--
300 kHz to 2 MHz	--	0.004	--	0.001	0.01	--
2 MHz to 100 MHz	--	0.004	--	0.001	0.01	0.025

¹ Ratioed measurement, nominal power at test port.

Table 58. Trace Noise¹ Phase (deg rms), All Options

Description	Specification			
	1 kHz IFBW	1 kHz IFBW	100 kHz IFBW	600 kHz IFBW
10 MHz to 100 MHz ²	0.051	0.0237	0.341	0.663
100 MHz to 13.5 GHz ²	0.015	0.0045	0.027	0.067
13.5 GHz to 16 GHz	0.042	0.0045	0.019	0.042
16 GHz to 22.5 GHz	0.042	0.0075	0.024	0.050
22.5 GHz to 24 GHz	0.054	0.0080	0.031	0.073
24 GHz to 26.5 GHz	0.054	0.0128	0.049	0.118

¹ Ratioed measurement, nominal power at test port.

² With an LFE option installed and LFE disabled, applied to frequencies ≤ 100 MHz. Above 100 MHz, performance is the same for both LFE enabled or disabled. For LFE enabled performance ≤ 100 MHz, see Table 59.

Table 59. Trace Noise¹ Phase (deg rms), All Ports, All LFE Options (LFE Enabled)

Description	Specification		Typical			
	100 Hz IFBW	1 kHz IFBW	100 Hz IFBW	1 kHz IFBW	100 kHz IFBW	600 kHz IFBW
500 Hz to 900 Hz	--	--	0.012	--	--	--
900 Hz to 4 kHz	0.03	--	0.008	--	--	--
4 kHz to 300 kHz	--	0.03	--	0.014	--	--
300 kHz to 2 MHz	--	0.03	--	0.007	0.064	--
2 MHz to 100 MHz	--	0.03	--	0.007	0.068	0.166

¹ Ratioed measurement, nominal power at test port.

Table 60. Reference Level Magnitude, All Options - Specification

Description	Magnitude (dB)	Phase (°)
Range	±500	±500
Resolution	0.001	0.01

Table 61. Stability¹, All Options - Typical

Description	Magnitude (dB/°C)	Phase (°/°C)
10 MHz to 50 MHz ²	0.010	0.180
50 MHz to 500 MHz ²	0.010	0.060
500 MHz to 3.2 GHz	0.010	0.080
3.2 GHz to 10 GHz	0.020	0.130
10 GHz to 13.5 GHz	0.020	0.160
13.5 GHz to 16 GHz	0.020	0.300
16 GHz to 20 GHz	0.020	0.400
20 GHz to 24 GHz	0.030	0.500
24 GHz to 26.5 GHz	0.030	0.560

¹ Stability is defined as a ratio measurement made at the test port.

² With an LFE option installed and LFE disabled, applied to frequencies ≤ 100 MHz. Above 100 MHz, performance is the same for both LFE enabled or disabled. For LFE enabled performance ≤ 100 MHz, see Table 62.

Table 62. Stability¹, All LFE Options (LFE Enabled) - Typical

Description	Magnitude (dB/°C)	Phase (°/°C)
500 Hz to 900 Hz	0.010	0.2
900 Hz to 1 kHz	0.010	0.2
1 kHz to 10 kHz	0.010	0.2
10 kHz to 100 kHz	0.010	0.2
100 kHz to 1 MHz	0.010	0.1
1 MHz to 5 MHz	0.010	0.1
5 MHz to 10 MHz	0.010	0.1
10 MHz to 50 MHz	0.010	0.1
50 MHz to 100 MHz	0.020	0.1

¹ Stability is defined as a ratio measurement made at the test port.

Table 63. Damage Input Level, All Options - Specification

Description	Option 200, 201, 219, 400, 401, 419	Option 217, 417	All LFE Options
RF, DC	30 dBm, 40 V	30 dBm, 7 V	20 dBm, 50 V

Phase Noise Measurement Performance (with S930317B phase noise measurement application)¹

- Offset frequency range: 0.1 Hz to 10 MHz
- Sweep speed (typical): 34 seconds (1 Hz to 10 MHz offset in Normal mode)

Table 64. Absolute Phase Noise Sensitivity (dBc/Hz), in Best mode - Supplemental Performance Data ²

Input Power level: +5 dBm (-5 dBm at 50 GHz)

Phase Noise	Offset Frequency								
Input Frequency	1 Hz	10 Hz	100 Hz	1 kHz	10 kHz	100 kHz	300 kHz	1 MHz	10 MHz
1 GHz	-55	-88	-112	-127	-132	-134	-134	-134	-134
10 GHz	-36	-69	-97	-117	-124	-130	-132	-136	-137
20 GHz	-31	-64	-90	-111	-120	-124	-125	-132	-134
40 GHz	-23	-58	-84	-104	-113	-117	-123	-125	-129
50 GHz	-18	-54	-81	-100	-109	-113	-116	-121	-123

Table 65. Absolute AM Noise Sensitivity (dBc/Hz), in Best mode - Supplemental Performance Data

Input Power level: +5 dBm (-5 dBm at 50 GHz)

AM Noise	Offset Frequency								
Input Frequency	1 Hz	10 Hz	100 Hz	1 kHz	10 kHz	100 kHz	300 kHz	1 MHz	10 MHz
1 GHz	-96	-104	-110	-119	-128	-132	-132	-135	-137
10 GHz	-97	-104	-110	-118	-128	-134	-135	-138	-139
20 GHz	-96	-104	-112	-116	-125	-132	-129	-136	-136
40 GHz	-93	-102	-109	-114	-123	-127	-130	-130	-132
50 GHz	-91	-96	-105	-114	-119	-122	-117	-125	-122

¹ The input frequency in the sensitivity tables in this section is limited to the highest frequency of the PNA model.

² For embedded-LO frequency converters, the frequency used for the table should be that of the embedded-LO.

Absolute Phase Noise Sensitivity (dBc/Hz) - Supplemental Performance Data

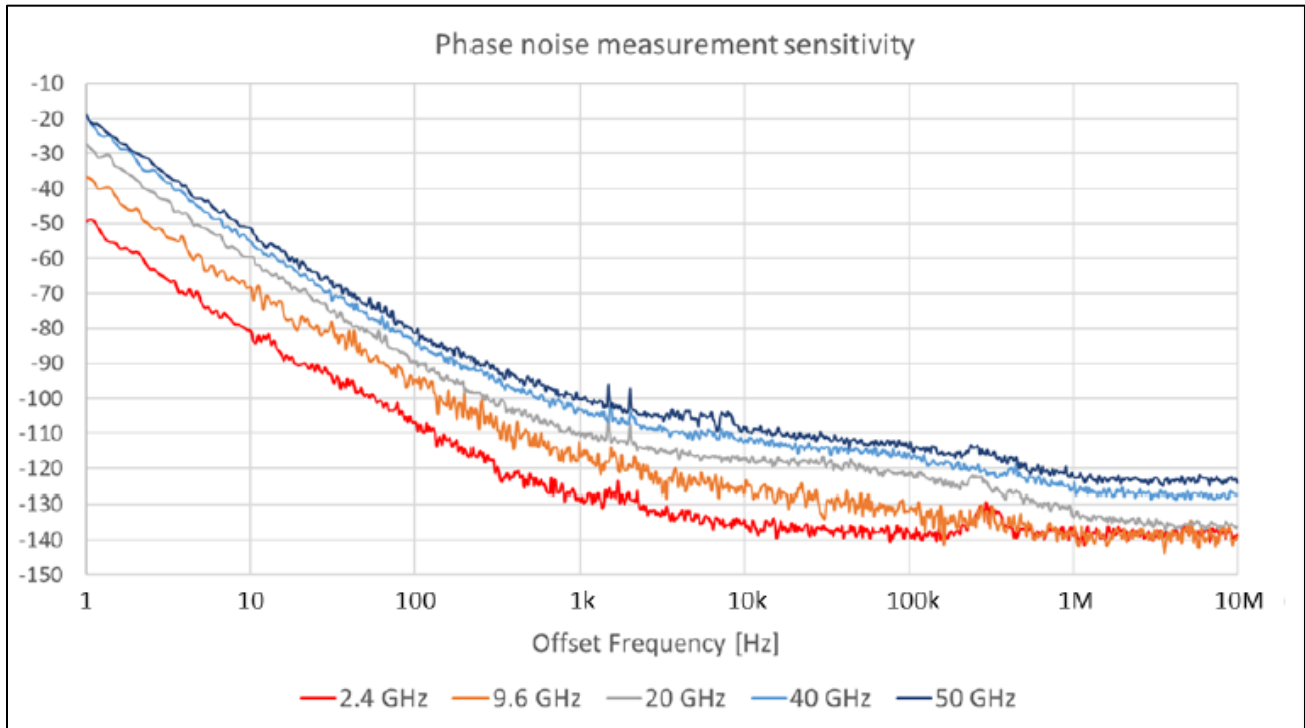

Single-Channel Residual Noise Measurement ³

Table 66. Single-Channel Residual Phase Noise Sensitivity (dBc/Hz), with Option UNY in Best mode - Supplemental Performance Data

Input Power level: +10 dBm (+6 dBm at 40 GHz, -2 dBm at 50 GHz)

Residual Phase Noise	Offset Frequency								
	1 Hz	10 Hz	100 Hz	1 kHz	10 kHz	100 kHz	300 kHz	1 MHz	10 MHz
Input Frequency									
1 GHz	-102	-110	-115	-123	-131	-136	-136	-137	-137
10 GHz	-92	-99	-105	-113	-122	-131	-134	-139	-140
20 GHz	-83	-93	-100	-112	-118	-125	-124	-132	-136
40 GHz	-78	-85	-93	-106	-110	-122	-126	-128	-129
50 GHz	-75	-81	-91	-102	-110	-120	-119	-125	-125

Table 67. Single-Channel Residual AM Noise Sensitivity (dBc/Hz), with Option UNY in Best mode - Supplemental Performance Data

Input Power level: +10 dBm (+6 dBm at 40 GHz, -2 dBm at 50 GHz)

Residual AM Noise	Offset Frequency								
	1 Hz	10 Hz	100 Hz	1 kHz	10 kHz	100 kHz	300 kHz	1 MHz	10 MHz
Input Frequency									
1 GHz	-97	-104	-112	-120	-117	-128	-130	-134	-138
10 GHz	-97	-106	-111	-120	-121	-129	-134	-137	-142
20 GHz	-99	-104	-112	-120	-123	-120	-123	-130	-136
40 GHz	-96	-102	-110	-117	-118	-128	-132	-131	-133
50 GHz	-91	-99	-109	-114	-120	-125	-118	-125	-127

³ The data is when a THRU device is connected, in other words, when the input and output frequencies are the same. The single-channel residual noise measurement is used for the phase noise measurements for frequency converting devices, and the sensitivity is determined as the absolute phase noise sensitivity at the embedded-LO frequency (Table 64). In the single-channel residual noise measurement mode, the phase or AM noise of the DUT input signal is not measured. The measurement can be done when the phase or AM noise of the signal generated by the DUT is larger than that of the DUT input signal supplied by the PNA internal signal source.

Single-Channel Residual Phase Noise Sensitivity (dBc/Hz) - Supplemental Performance Data

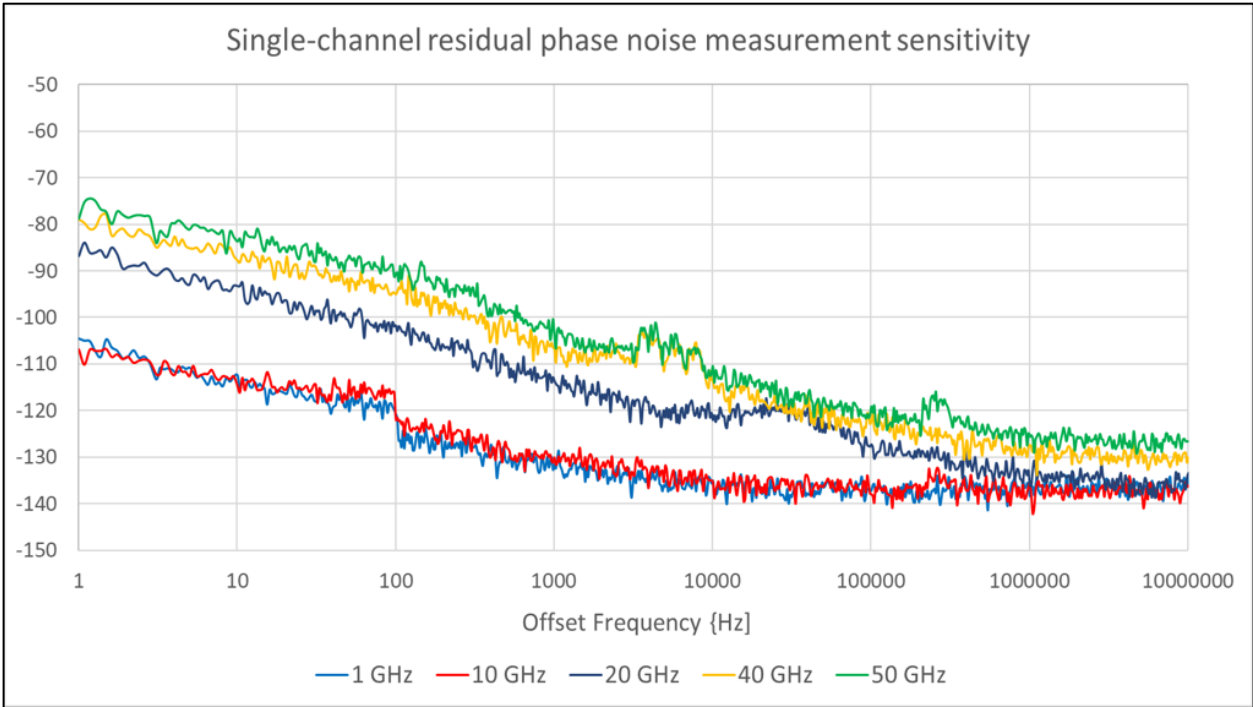

Table 68. Single-Channel Residual Phase Noise Sensitivity (dBc/Hz), without Option UNY in Best mode - Supplemental Performance Data ⁴

Input Power level: +10 dBm (+6 dBm at 40 GHz, 0 dBm at 50 GHz)

Residual Phase Noise	Offset Frequency								
	Input Frequency	1 Hz	10 Hz	100 Hz	1 kHz	10 kHz	100 kHz	300 kHz	1 MHz
1 GHz	-94	-95	-100	-120	-133	-136	-138	-137	-136
10 GHz	-77	-78	-83	-102	-114	-124	-129	-135	-138
20 GHz	-70	-74	-75	-95	-109	-118	-127	-128	-133
40 GHz	-64	-67	-70	-92	-102	-112	-116	-121	-128
50 GHz	-61	-63	-66	-87	-101	-109	-113	-119	-125

Table 69. Single-Channel Residual AM Noise Sensitivity (dBc/Hz), without Option UNY in Best mode - Supplemental Performance Data

Input Power level: +10 dBm (+6 dBm at 40 GHz, 0 dBm at 50 GHz)

Residual AM Noise	Offset Frequency								
	Input Frequency	1 Hz	10 Hz	100 Hz	1 kHz	10 kHz	100 kHz	300 kHz	1 MHz
1 GHz	-105	-110	-123	-125	-134	-138	-139	-143	-138
10 GHz	-104	-110	-116	-125	-133	-134	-133	-141	-141
20 GHz	-104	-109	-116	-127	-127	-126	-128	-133	-137
40 GHz	-103	-110	-115	-125	-120	-130	-126	-130	-132
50 GHz	-98	-106	-111	-121	-124	-125	-122	-129	-129

⁴ The data is when a THRU device is connected, in other words, when the input and output frequencies are the same. The single-channel residual noise measurement is used for the phase noise measurements for frequency converting devices, and the sensitivity is determined as the absolute phase noise sensitivity at the embedded-LO frequency (Table 64). In the single-channel residual noise measurement mode, the phase or AM noise of the DUT input signal is not measured. The measurement can be done when the phase or AM noise of the signal generated by the DUT is larger than that of the DUT input signal supplied by the PNA internal signal source.

2-Channel Residual Noise Measurement for Non-Frequency Converting Devices⁵

Table 70. 2-Channel Residual Phase Noise Sensitivity (dBc/Hz) in Best mode - Supplemental Performance Data

Input Power level: +10 dBm (+6 dBm at 40 GHz, -3 dBm at 50 GHz)

Residual Phase Noise	Offset Frequency								
	1 Hz	10 Hz	100 Hz	1 kHz	10 kHz	100 kHz	300 kHz	1 MHz	10 MHz
1 GHz	-107	-116	-127	-134	-132	-134	-131	-133	-132
10 GHz	-101	-110	-120	-126	-134	-135	-134	-138	-136
20 GHz	-99	-105	-113	-120	-128	-131	-129	-134	-135
40 GHz	-93	-101	-109	-115	-121	-124	-125	-126	-127
50 GHz	-90	-99	-106	-113	-117	-118	-119	-120	-120

Table 71. 2-Channel Residual AM Noise Sensitivity (dBc/Hz) in Best mode - Supplemental Performance Data

Input Power level: +10 dBm (+6 dBm at 40 GHz, -3 dBm at 50 GHz)

Residual AM Noise	Offset Frequency								
	1 Hz	10 Hz	100 Hz	1 kHz	10 kHz	100 kHz	300 kHz	1 MHz	10 MHz
1 GHz	-99	-106	-109	-120	-131	-133	-138	-137	-134
10 GHz	-95	-105	-113	-121	-130	-134	-136	-139	-139
20 GHz	-96	-104	-113	-120	-129	-128	-129	-136	-136
40 GHz	-98	-107	-112	-118	-120	-127	-129	-130	-131
50 GHz	-93	-102	-110	-115	-120	-121	-119	-122	-122

⁵ Both the phase or AM noise of the DUT input signal and that of the DUT output signal are measured.

2-Channel Residual Phase Noise Sensitivity (dBc/Hz) - Supplemental Performance Data

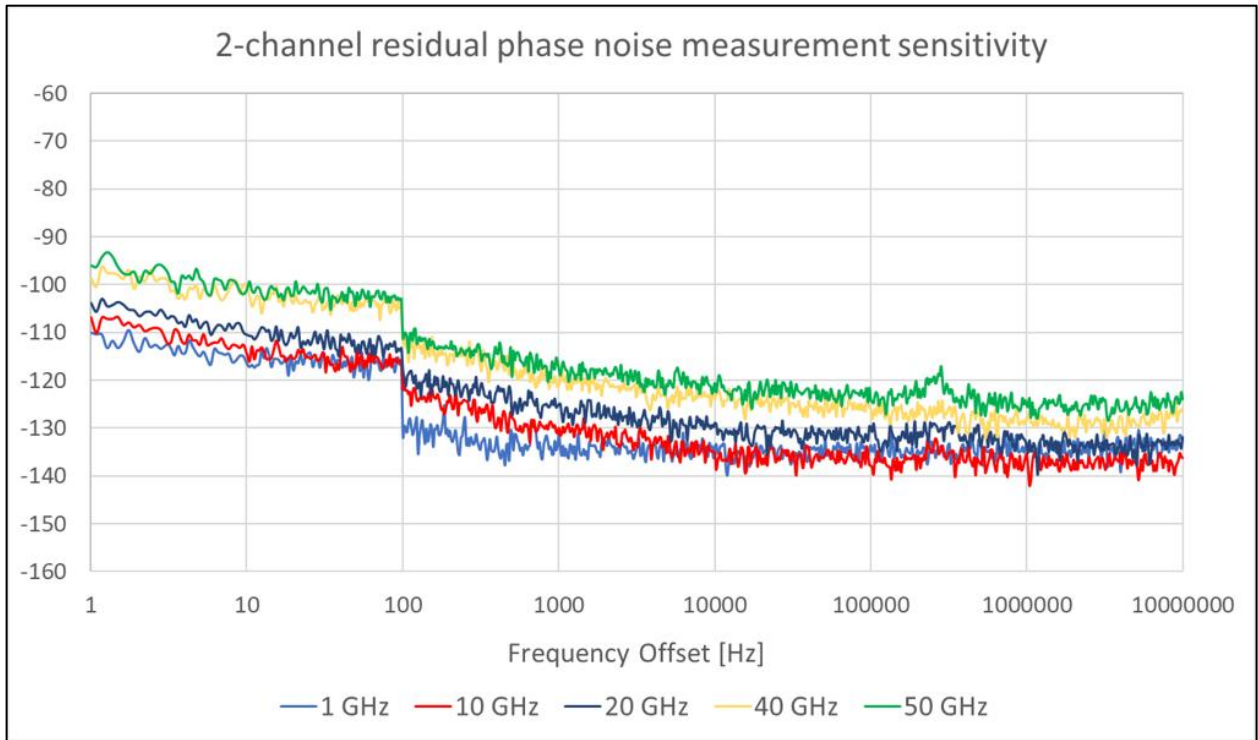

Dynamic Accuracy

Standard receiver accuracy of the test port input power reading relative to the reference input power level. It is verified with the following measurements:

- Compression over frequency

IF linearity at a single frequency of either 99.6 MHz or 1.998765 GHz using a reference level of -20 dBm for an input power range of 0 to -60 dBm. For value below -60 dBm, refer to [VNA Receiver Dynamic Accuracy Specifications and Uncertainties](#).

Please download our free Uncertainty Calculator from http://www.keysight.com/find/na_calculator to generate the curves for your PNA.

Table 72. N5221B and N5222B Dynamic Accuracy - Specification

N5221B/22B Dynamic Accuracy, 900 Hz, All LFE Options (LFE Enabled) - Specification

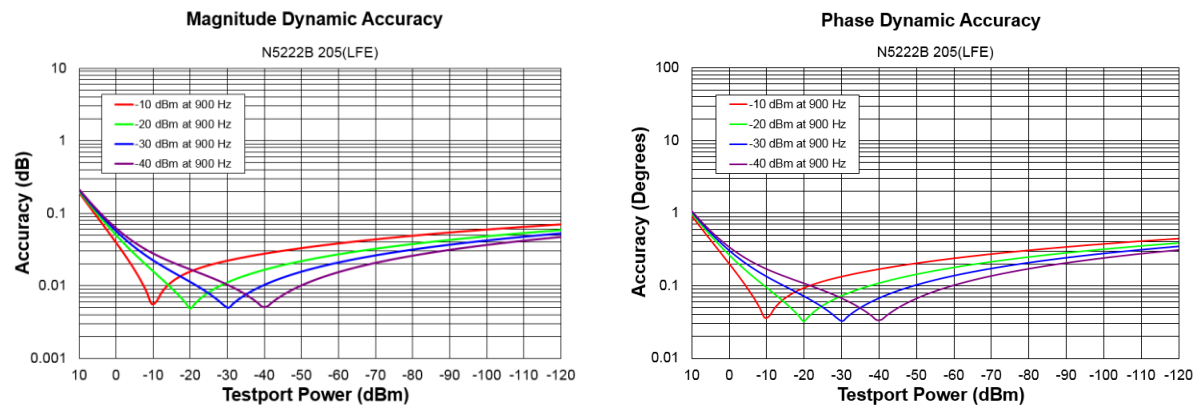

N5221B/22B Dynamic Accuracy, 10 MHz, All LFE Options (LFE Enabled) - Specification

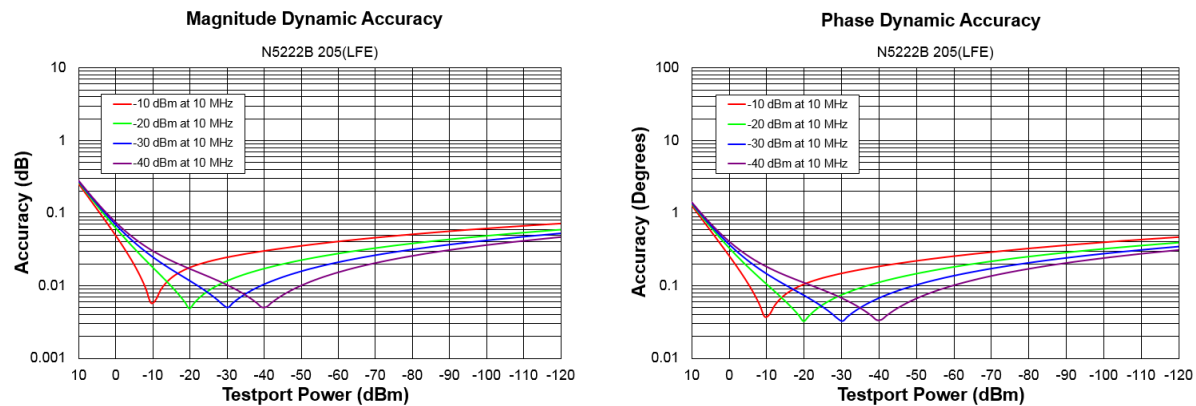

N5221B/22B Dynamic Accuracy, 100 MHz, All LFE Options (LFE Enabled) - Specification

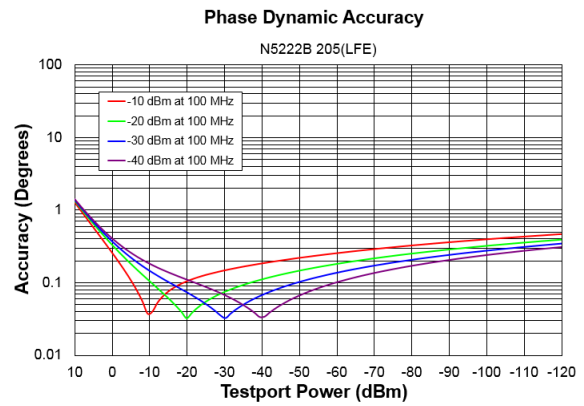
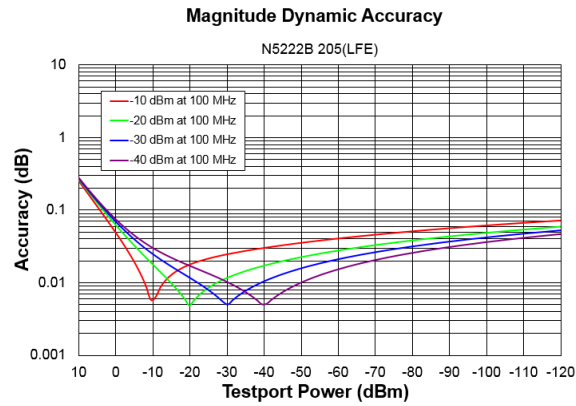

N5221B/22B Dynamic Accuracy, 10 MHz to 50 MHz - Specification

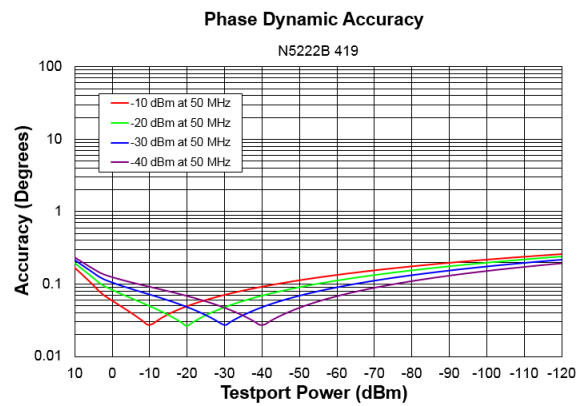
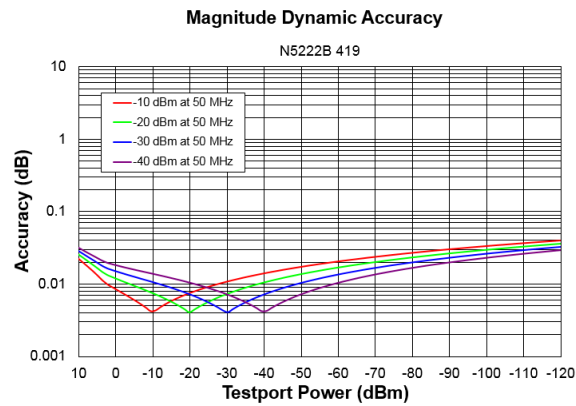

N5221B/22B Dynamic Accuracy, 50 MHz to 500 MHz - Specification

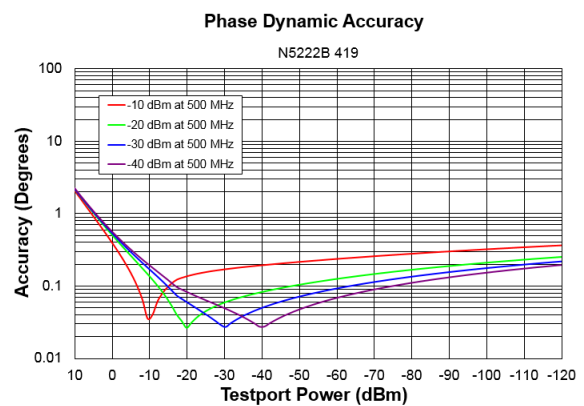
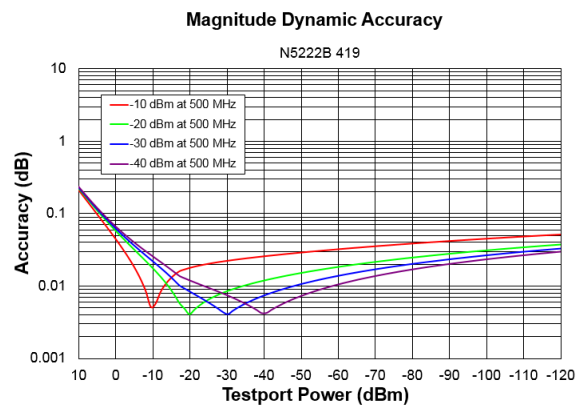

N5221B/22B Dynamic Accuracy, 500 MHz to 1 GHz - Specification

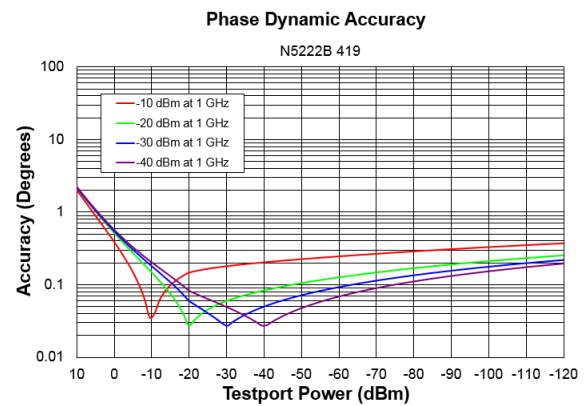
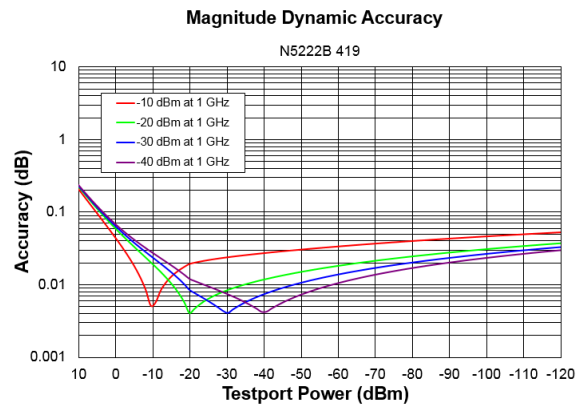

N5221B/22B Dynamic Accuracy, 1 GHz to 2 GHz - Specification

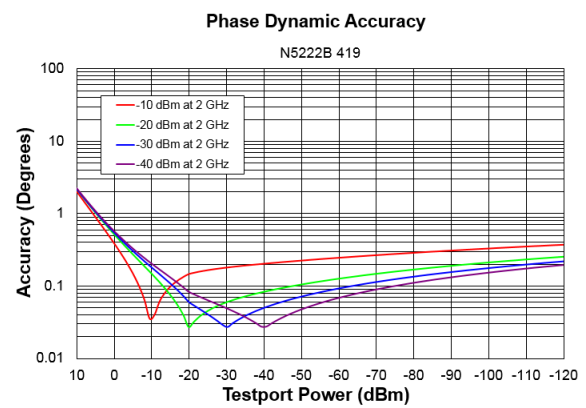
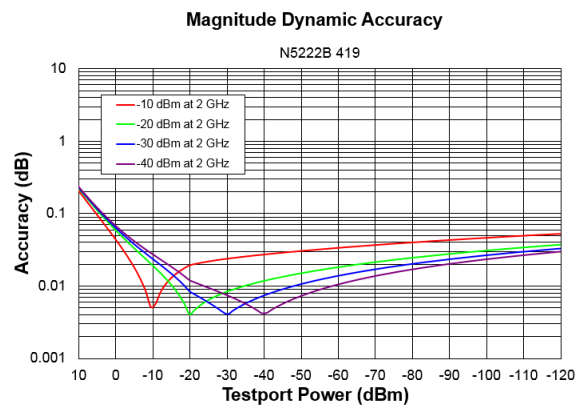

N5221B/22B Dynamic Accuracy, 2 GHz to 20 GHz - Specification

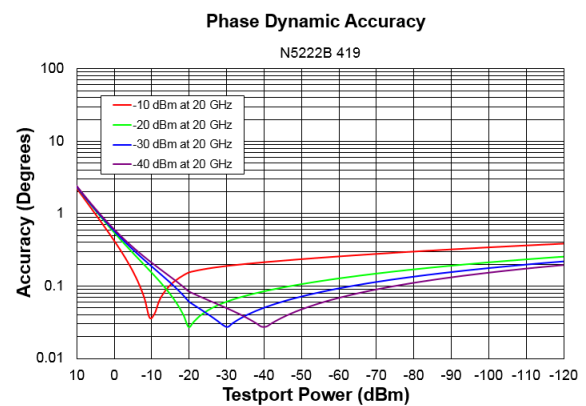
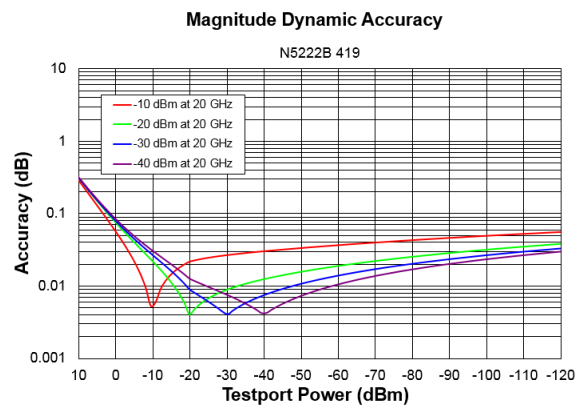

N5221B/22B Dynamic Accuracy, 20 GHz to 26.5 GHz - Specification

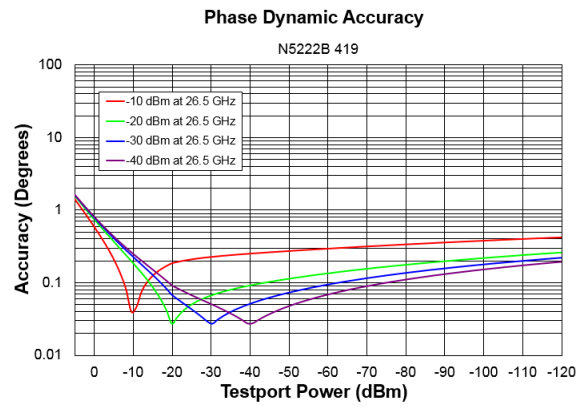
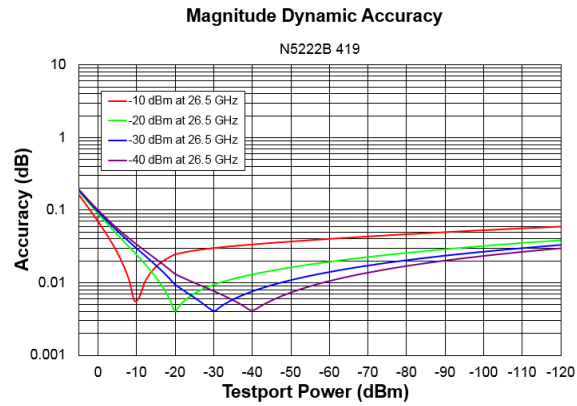
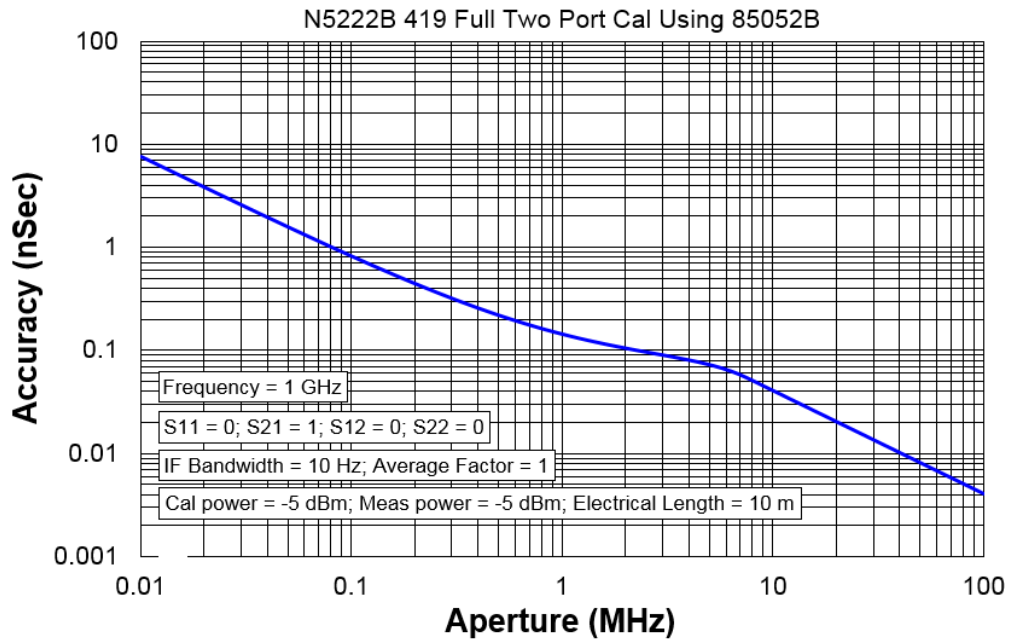

Table 73. Group Delay¹ - Typical

Description	Typical Performance
Aperture (selectable)	(frequency span)/(number of points -1)
Maximum Aperture	20% of frequency span
Range	0.5 x (1/minimum aperture)
Maximum Delay	Limited to measuring no more than 180° of phase change within the minimum aperture.)
Accuracy	See graph below. Char.

The following graph shows characteristic group delay accuracy with full 2-port calibration and a 10 Hz IF bandwidth. Insertion loss is assumed to be < 2 dB and electrical length to be ten meters.
 For any S_{ij} Group Delay measurement, S_{ii} = 0, S_{ij} = 1, S_{ji} = 0, S_{kl} = 0 for all kl ≠ ij

Group Delay Accuracy (Typical)



In general, the following formula can be used to determine the accuracy, in seconds, of specific group delay measurement:
 $\pm \text{Phase Accuracy (deg)} / [360 \times \text{Aperture (Hz)}]$
 Depending on the aperture and device length, the phase accuracy used is either incremental phase accuracy or worst-case phase accuracy.

¹ Group delay is computed by measuring the phase change within a specified frequency step (determined by the frequency span and the number of points per sweep).

General Information

Table 74. Miscellaneous Information

Description	Supplemental Information	
System IF Bandwidth Range	1 Hz to 15 MHz, nominal	
CPU	For the latest information on CPUs and associated hard drives, visit: <u>PNA Hard Drives and CPUs (keysight.com)</u>	
LXI	CPU version 7.0, 8.0	CPU version 9.0
	Class C	LXI 1.5 Extended Functions: HiSLIP; VSI-11 Discovery and Identification
Maximum Number of Points	100003	

Table 75. Front Panel Information, All Options

Description	Typical Performance
RF Connectors	
Type	3.5 mm (male), 50 ohm (nominal)
Center Pin Recession	0.002 in. (characteristic)
USB 2.0 Ports - Primary (4 ports)	
Standard	Compatible with USB 2.0
Connector	USB Type-A female
Display	
Size	31 cm (12.1 in) diagonal color active matrix LCD; 1280 (horizontal) X 800 (vertical) resolution
Refresh Rate	Vertical 60 Hz; Horizontal 49.31 kHz
Pixels	Any of the following would cause a display to be considered faulty: <ul style="list-style-type: none"> • A complete row or column consists of “stuck” or “dark” pixels. • More than six “stuck on” pixels (but not more than three green) or more than 0.002% of the total pixels are within the LCD specifications. • More than twelve “dark” pixels (but no more than seven of the same color) or more than 0.004% of the total pixels are within the LCD specifications. • Two or more consecutive “stuck on” pixels or three or more consecutive “dark” pixel (but no more than one set of two consecutive dark pixels). • “Stuck on” pixels or more than two “dark” pixels less than 6.5 mm apart (excluding consecutive pixels).

Description	Typical Performance
Display Range	
Magnitude	± 2500 dB (at 500 dB/div), max
Phase	$\pm 2500^\circ$ (at 500 degrees/div), max
Polar	10 pUnits, min 10,000 Units, max
Display Resolution	
Magnitude	0.001 dB/div, min
Phase	0.01°/div, min
Marker Resolution	
Magnitude	0.001 dB, min
Phase	0.01°, min
Polar	10 pUnit, min

Table 76. Rear Panel Information, All Options

Description	Typical Performance
10 MHz Reference In	
Connector	BNC, female
Input Frequency	10 MHz ± 1 ppm, 100 MHz ± 1 ppm 20 MHz ± 1 ppm, 80 MHz ± 1 ppm
Input Level	10 MHz: -15 dBm to +20 dBm 100 MHz: -10 dBm to +20 dBm
Input Impedance	50 Ω , nom.
10 MHz Reference Out	
Connector	BNC, female
Output Frequency	10 MHz ± 0.7 ppm, 100 MHz ± 0.7 ppm
Signal Type	Sine Wave
Output Level	+10 dBm ± 4 dB into 50 Ω
Output Impedance	50 Ω , nominal
Harmonics	<-40 dBc, typical
External IF Inputs	
Function	Allows use of external IF signals from remote mixers, bypassing the PNA's first converters
Connectors	SMA (female); A, B, C, D, R (4-port); A, B, R1, R2 (2-port)

Description	Typical Performance
Input Frequency Normal IF path	RF < 53 MHz: IF = 826.446 KHz RF >= 53 MHz: IF = 7.438 MHz
Narrowband IF path	IF = 10.70 MHz
Input Impedance	50 Ω
RF Damage Level	+23 dBm
DC Damage Level	5.5 VDC
0.1 dB Compression Point Normal IF path Narrowband IF path	-9.0 dBm at 7.438 MHz -17 dBm at 10.70 MHz
Pulse I/O Connector	15-pin mini D-sub (for pin assignment information, refer to the PNA online help)
Pulse Inputs (IF Gates)	
Function	Internal receiver gates used for point-in-pulse and pulse-profile measurements
Input Impedance	1 K Ohm
Minimum Pulse Width, Source Modulators	20 ns
Minimum Pulse Width, Receiver Gates	20 ns
DC Damage Level	5.5 VDC
Drive Voltage	0 V (off), +3.3 V (on), nominal
RF Pulse Modulator Input (Source Modulator)	
On/Off Ratio	
10 MHz to 3.2 GHz	-64 dB
3.2 GHz to 26.5 GHz	-80 dB
Pulse Period	
Minimum	20 ns
Maximum	70 s
Pulse Outputs	
Voltage (TTL)	High: 3.3V to 3.5V Low: <1V
Impedance	50 Ohm
External Test Set Driver	
Function	Used for driving remote mixers
Connections	3.5 (female)
RF Output Frequency Range	3.2 GHz to 19 GHz
LO Output Frequency Range	0.01 to 26.5 GHz

Description	Typical Performance	
Rear Panel LO Power	Upper Limit, Typical (dBm)	Lower Limit, Typical (dBm)
10 MHz to 1.7 GHz	--	--
1.7 GHz to 16 GHz	0	-10
16 GHz to 21 GHz	4	-6
21 GHz to 26.5 GHz	6	-4
Rear Panel RF Power	Upper Limit, Typical (dBm)	Lower Limit, Typical (dBm)
3.2 GHz to 19 GHz	-3	-8
Bias Tee Inputs		
Connectors	BNC(f) for ports 1, 2, 3 and 4	
Fuse	500 mA, bi-pin style	
Maximum Bias Current	±200 mA with no degradation of RF specifications	
Maximum Bias Voltage	±40 VDC	
Other Rear Panel Interface		
Trigger Inputs/Outputs	BNC(f), TTL/CMOS compatible	
Test Set IO	25-pin D-Sub connector, available for external test set control	
Power IO	9-pin D-Sub, female; analog and digital IO	
Handler IO	36-pin parallel I/O port; all input/output signals are default set to negative logic; can be reset to positive logic via GPIB command	
GPIB	Two ports - dedicated controller and dedicated talker/listener. 24-pin D-sub (Type D-24), female; compatible with IEEE-488	
CPU Version	CPU version 7.0, 8.0	CPU version 9.0
PCIe	Cabled PCIe x4 connector is a 4-lane slot	N/A
USB Ports	Two SuperSpeed USB ports (900 mA each), one USB port below LAN connector, and one USB device port. There are also four USB ports (500 mA each) on the front panel. The total current limit for all rear panel USB ports is 2.3 amps. The total current limit for all front panel USB ports is 2 amps.	Four SuperSpeed USB ports (900 mA each) and one USB device port. There are also four USB ports (500 mA each) on the front panel. The total current limit for all rear panel USB ports is 3.6 amps. The total current limit for all front panel USB ports is 2 amps.

Description	Typical Performance	
USB-C (Host)	N/A	Two USB-C connectors with support for USB-3.1 (max Power Delivery of 5V@1A), Thunderbolt3 (max Power Delivery of 5V@1A) ¹ , and Display Port (port TB1 only)
LAN	1G port; 10/100/1000 BaseT Ethernet, 8-pin configuration; auto selects between the data rates	1G and 10G ports; 10GBASE-T, Ethernet, 8-pin configuration; auto selects between the data rates. Works with Cat6/Cat7 cable.
VGA Video Output	15-pin mini D-Sub; Drives VGA compatible monitors	N/A
Mini DisplayPort	Miniature DisplayPort connector for connection to external displays	N/A
DisplayPort	N/A	Standard DisplayPort connector for connection to external displays
Line Power		
Frequency, Voltage	50/60/400 Hz for 100/120 VAC 50/60 Hz for 220/240 VAC	
	Power supply is auto switching	
Max	575 watts	

¹ High power devices require external power supply

Table 77. Analyzer Dimensions and Weight

All models are shipped with bottom feet, handles, and front and rear hardware.

Cabinet Dimensions	Metric (mm)	Imperial (inches)
Height		
Without bottom feet:EIA RU ¹ = 6	266.1	10.5
With bottom feet	279.1	11.0
Width		
Without handles or rack-mount flanges	425.6	16.8
With handles, without rack-mount flanges	458.7	18.1
With handles and rack-mount flanges	482.9	19.0
Depth		
Without front and rear panel hardware	533.0	21.0
With front and rear panel hardware, handles	578.0	22.7
Weight (nominal)	Net	Shipping
2-port models	27 kg (60 lb)	43 kg (95 lb)
4-port models	36.7 kg (81 lb)	51 kg (112 lb)

¹ Electronics Industry Association rack units. 1 RU = 1.75 in.

Regulatory and Environmental Information

For Regulatory and Environmental information, refer to the PNA Series Installation and Quick Start Guide, located online at <http://literature.cdn.keysight.com/litweb/pdf/E8356-90001.pdf>.

Measurement Throughput Summary

Cycle time Includes sweep time, retrace time and band-crossing time. Analyzer display turned off with DISPLAY:ENABLE OFF. Add 21 ms for display on. Data for one trace (S11) measurement. LF Auto BW off.

Table 78. Cycle Time (ms) for Measurement Completion, All Models, All Options - Typical

Sweep Range	IF Bandwidth		Number of Points				
			201	401	1601	16001	32001
50 kHz to 100 MHz	10 kHz	Uncorrected	66.8	129.3	529	4870	9988
		2-Port cal	133	255.3	984	9919	19707
	1 kHz	Uncorrected	289.7	574	2282	22831	45609
		2-Port cal	580	1148	4564	45746	91737
	100 Hz	Uncorrected	2562	5044	20143	201207	402348
		2-Port cal	5056	10087	40291	402482	805000
9 GHz to 10 GHz	600 kHz	Uncorrected	3.7	4.2	8.1	54	109.7
		2-Port cal	7.6	8.7	16.6	109	216.8
	10 kHz	Uncorrected	29.8	53.2	201.8	1990	3998
		2-Port cal	61.2	107.4	404	3978	7981
	1 kHz	Uncorrected	201.8	399	1585	15812	31643
		2-Port cal	403	798	3169	31664	63412
10 GHz to 20 GHz	600 kHz	Uncorrected	14.6	13.6	14.7	59.3	110.2
		2-Port cal	26.6	27	29.2	120.1	256.5
	10 kHz	Uncorrected	43.8	82.3	223	1995	3983
		2-Port cal	104	163.2	412	4002	7962
	1 kHz	Uncorrected	212	402	1588	15816	31625
		2-Port cal	409	804	3198	31636	63376

Table 79. N5221B Cycle Time (ms) for Full-Span Measurement Completion - Typical

10 MHz to 13.5 GHz		Number of Points				
IF Bandwidth		201	401	1601	16001	32001
600 kHz	Uncorrected	23.6	32.7	44.4	89.3	141.9
	2-Port cal	47.6	65.2	82	177.4	301.3
10 kHz	Uncorrected	51.4	94.3	306	2155	4030
	2-Port cal	104.8	188.4	611	4321	8098
1 kHz	Uncorrected	212.3	416	1641	16200	32388
	2-Port cal	424	829	3296	32397	64922

Table 80. N5222B Cycle Time (ms) for Full-Span Measurement Completion - Typical

10 MHz to 26.5 GHz		Number of Points				
IF Bandwidth		201	401	1601	16001	32001
600 kHz	Uncorrected	27.5	39	57	98.2	145.2
	2-Port cal	55.2	80.6	115	184.4	289.7
10 kHz	Uncorrected	53.6	95.1	337	2295	4103
	2-Port cal	107.1	189.4	697	4560	8203
1 kHz	Uncorrected	214.5	415	1645	16018	32021
	2-Port cal	431	854	3232	32035	64221

Table 81. Cycle Time vs. IF Bandwidth - Typical

Applies to the **Preset condition** (201 points, correction off) except for the following changes:

- CF = 10 GHz
- Span = 100 MHz
- Display off (add 21 ms for display on)

Cycle time includes sweep and retrace time.

Description	N5221B/22B	
	IF Bandwidth (Hz)	Cycle Time (ms)
600,000	2.4	0.0045
100,000	3.5	0.0018
30,000	6.9	0.0011
10,000	26.8	0.0006
3,000	71.7	0.0004
1,000	206.5	0.0003
300	616	0.0002
100	1798	0.0002
30	5954	0.0002
10	17803	0.0002
3	59247	0.0002

Table 82. Cycle Time (ms) vs. Number of Points - Typical

Applies to the **Preset condition** (correction off) except for the following changes:

- CF = 10 GHz
- Span = 100 MHz
- Display off (add 21 ms for display on)

Cycle time includes sweep and retrace time.

Description	IF Bandwidth (Hz)			
	1,000	10,000	30,000	600,000
Number of Points				
3	4.7	2.2	2	1.9
11	12.7	3.9	2.7	2.1
51	53.2	8.1	3.1	1.9
101	101.7	14.4	4.8	2.8
201	205	26.9	6.9	2.4
401	398	51.7	12	3.3
801	813	104.7	22	4.4
1,601	1584	200.8	42.5	7.4
6,401	6326	824	162.8	22.3
16,001	15811	1989	401	59.3
32,001	31642	3975	803	106.9

Table 83. Data Transfer Time¹ (ms) - Typical

NOTE

The following was measured on a unit with Synthesizer 6.

Description	Number of Points				
	201	401	1601	16,001	32,001
SCPI over GPIB (Program executed on external PC ²)					
32-bit floating point	4.6	9.3	38	352	720
64-bit floating point	9.4	18.8	73.4	730	1455
ASCII	36.7	72.5	288	2882	5762
SCPI over SICL/LAN or TCP/IP Socket (Program executed in the analyzer)					
32-bit floating point	<1	<1	<1	1.2	2.4
64-bit floating point	<1	<1	<1	2.3	4.6
ASCII	2.1	4	15	148	295
COM ³ (Program executed in the analyzer)					
32-bit floating point	<1	<1	<1	<1	<1
Variant type	<1	<1	1.4	12.4	25.5
DCOM over LAN ³ (Program executed on external PC)					
32-bit floating point	<1	<1	<1	2.3	4.4
Variant type	<1	1.6	5.3	52	105.5

¹ Measured with the analyzer display off. Values will increase slightly if the analyzer display is on.

² Measured when using the SCPI command DISPlay: VISible OFF.

³ Values are for real and imaginary pairs, with the analyzer display off.

NOTE

Specifications for Recall & Sweep Speed are not provided for the N522xB analyzers.

Front-Panel Jumpers

NOTE

The following options have front-panel jumpers for each port:
201, 205, 217, 219, 220, 401, 405, 417, 419, 420

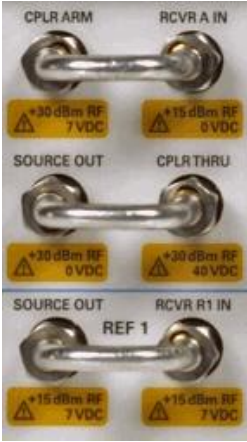

Table 84. Measurement Receiver Inputs (dBm) - Typical

(RCVR A, B, C, D IN) @ 0.1dB Typical Compression

Description	All Options
10 MHz to 500 MHz	-4
500 MHz to 3.2 GHz	-2
3.2 GHz to 10 GHz	-3
10 GHz to 13.5 GHz	-4
13.5 GHz to 26.5 GHz	-5

Table 85. Reference Receiver Inputs and Reference Source Outputs (dBm) - Typical

(RCVR R1 IN, REF 1 SOURCE OUT) @ Max Specified Output Power

Description	Option 201, 401	Option 217, 219, 417, 419
10 MHz to 50 MHz	-4	-4
50 MHz to 10 GHz	-3	-2
10 GHz to 16 GHz	-4	-2
16 GHz to 20 GHz	-5	-6
20 GHz to 24 GHz	-6	-7
24 GHz to 26.5 GHz	-14	-14

Table 86. Reference Receiver Inputs and Reference Source Outputs (dBm) - Typical

(RCVR R2 IN, RCVR R3 IN, RCVR R4 IN, REF 2 SOURCE OUT, REF 3 SOURCE OUT, REF 4 SOURCE OUT) @ Max Specified Output Power

Description	Option 201, 401		Option 401		Option 217, 219, 417, 419	
	RCVR R2 IN, RCVR R4 IN, REF 2 SOURCE OUT, REF 4 SOURCE OUT	RCVR R3 IN, REF 3 SOURCE OUT	RCVR R2 IN, RCVR R4 IN, REF 2 SOURCE OUT, REF 4 SOURCE OUT	RCVR R3 IN, REF 3 SOURCE OUT		
10 MHz to 50 MHz	-2	-2	-2	-2	-2	-2
50 MHz to 500 MHz	-1	-1	-1	-1	-1	-1
500 MHz to 3.2 GHz	-1	-1	-1	-1	0	0
3.2 GHz to 10 GHz	0	0	0	0	+1	+1
10 GHz to 16 GHz	0	0	0	0	+2	+2
16 GHz to 20 GHz	0	+1	+1	+1	-1	-1
20 GHz to 24 GHz	-2	+1	+1	+1	-3	0
24 GHz to 26.5 GHz	-8	-6	-6	-6	-9	-7

Table 87. Source Outputs (dBm) - Typical

(PORT 1 SOURCE OUT, PORT 2 SOURCE OUT, PORT 3 SOURCE OUT, PORT 4 SOURCE OUT) @ Max Specified Output Power

Description	Option 201, 401		Option 217, 219, 417, 419	
	PORT 1 SOURCE OUT, PORT 3 SOURCE OUT	PORT 2 SOURCE OUT, PORT 4 SOURCE OUT	PORT 1 SOURCE OUT, PORT 3 SOURCE OUT	PORT 2 SOURCE OUT, PORT 4 SOURCE OUT
10 MHz to 50 MHz	+12	+12	+12	+12
50 MHz to 500 MHz	+13	+13	+13	+13
500 MHz to 3.2 GHz	+13	+13	+14	+14
3.2 GHz to 10 GHz	+14	+14	+14	+14
10 GHz to 16 GHz	+14	+14	+15	+15
16 GHz to 20 GHz	+14	+13	+12	+12
20 GHz to 24 GHz	+14	+11	+12	+9
24 GHz to 26.5 GHz	+8	+6	+6	+4

Table 88. Coupler Inputs (dB) - Typical

(PORT 1 CPLR THRU, PORT 2 CPLR THRU, PORT 3 CPLR THRU, PORT 4 CPLR THRU) Insertion Loss of Coupler Thru

Description	Options 201, 401	Option 217, 219, 417, 419
10 MHz to 50 MHz	0	-0.50
50 MHz to 100 MHz	-0.25	-0.50
100 MHz to 500 MHz	-0.25	-1.00
500 MHz to 3.2 GHz	-0.50	-1.00
3.2 GHz to 10 GHz	-0.75	-1.25
10 GHz to 13.5 GHz	-1.00	-1.75
13.5 GHz to 16 GHz	-1.00	-2.00
16 GHz to 20 GHz	-1.20	-2.00
20 GHz to 24 GHz	-1.30	-2.50
24 GHz to 26.5 GHz	-1.50	-2.50

Table 89. Damage Level - Typical

Description	RF (dBm)	DC (v)
RCVR A, B, C, D IN	15	7
RCVR R1, R2, R3, R4 IN	15	7
REF 1 SOURCE OUT	15	7
REF 2, 3, 4 SOURCE OUT	30	7
PORT 1, 2, 3, 4 SOURCE OUT	30	7
PORT 1, 2, 3, 4 CPLR THRU	30 (20 ¹)	40 (50 ¹) (7 ²)
PORT 1, 2, 3, 4 CPLR ARM	30	7

¹ With an LFE option installed.

² With a thru connection between test ports of option 217, 222, 417 or 422 configuration, 7 VDC input to CPLR THRU ports damages the source attenuator on the connected port.

Test Set Block Diagrams

NOTE

For best readability, use a color printer for printing the following graphics.

Legend

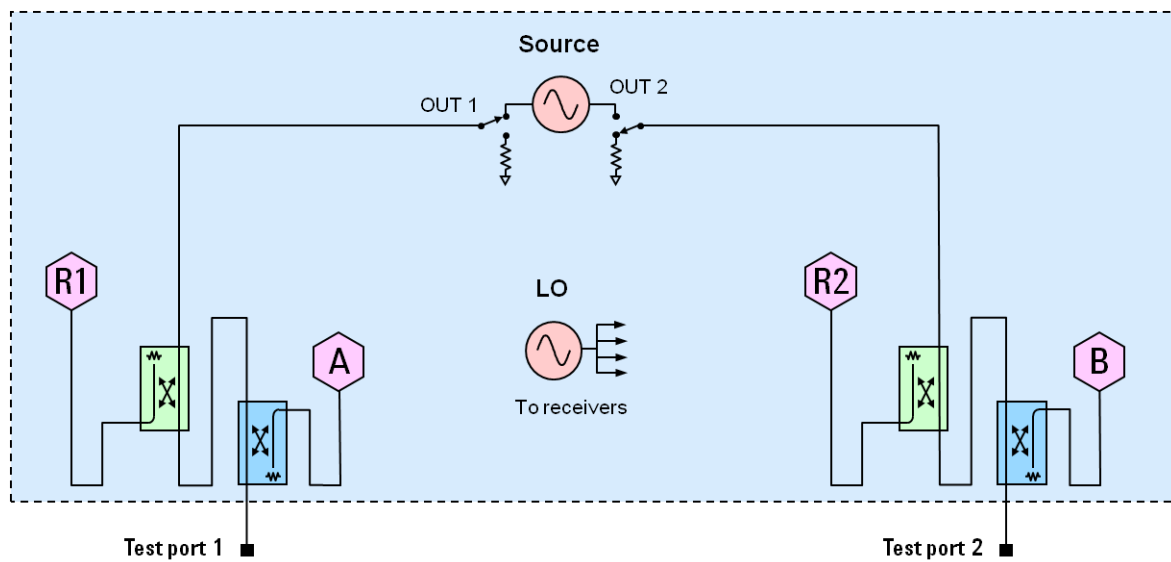
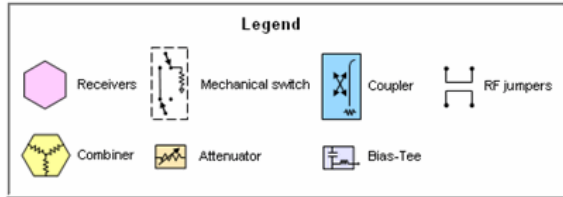

Figure 1. N5221B and N5222B Option 200 (2-port base model)

To base model, adds front-panel jumpers and R1 receiver switch

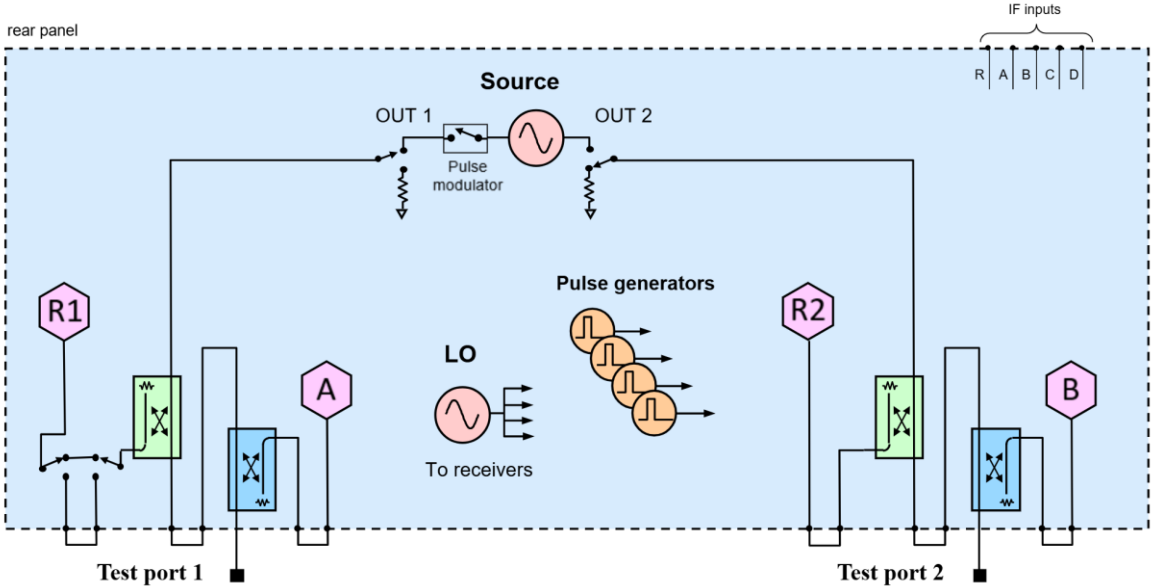

Figure 2. N5221B and N5222B Option 201

The following LFE block diagram shows how the low-frequency hardware is configured for a single test port. The other ports are configured similarly.

NOTE The attenuators do not apply to Options 205 and 405.

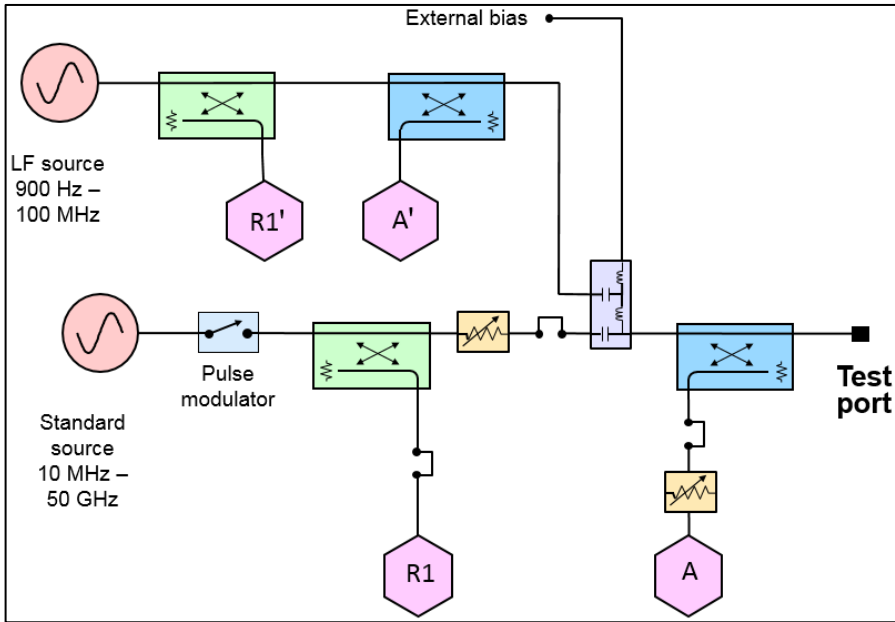

Figure 3. N5221B and N5222B LFE Options

To base model, adds front-panel jumpers, R1 receiver switch, and source and receiver attenuators (extended power range).

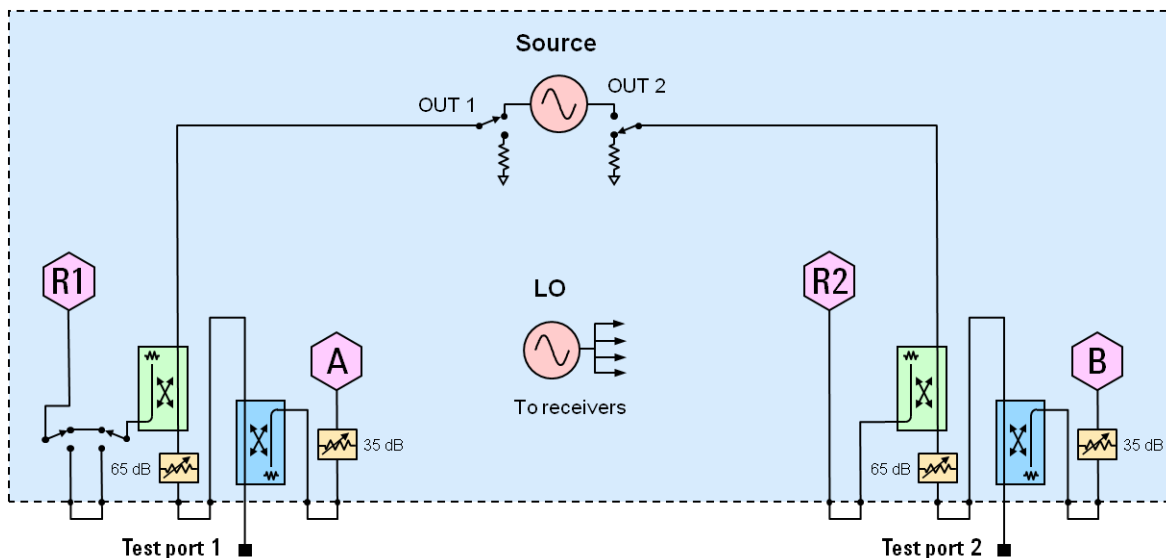

Figure 4. N5221B and N5222B Option 217

To base model, adds front-panel jumpers, R1 receiver switch, source and receiver attenuators (extended power range), and bias-tees.

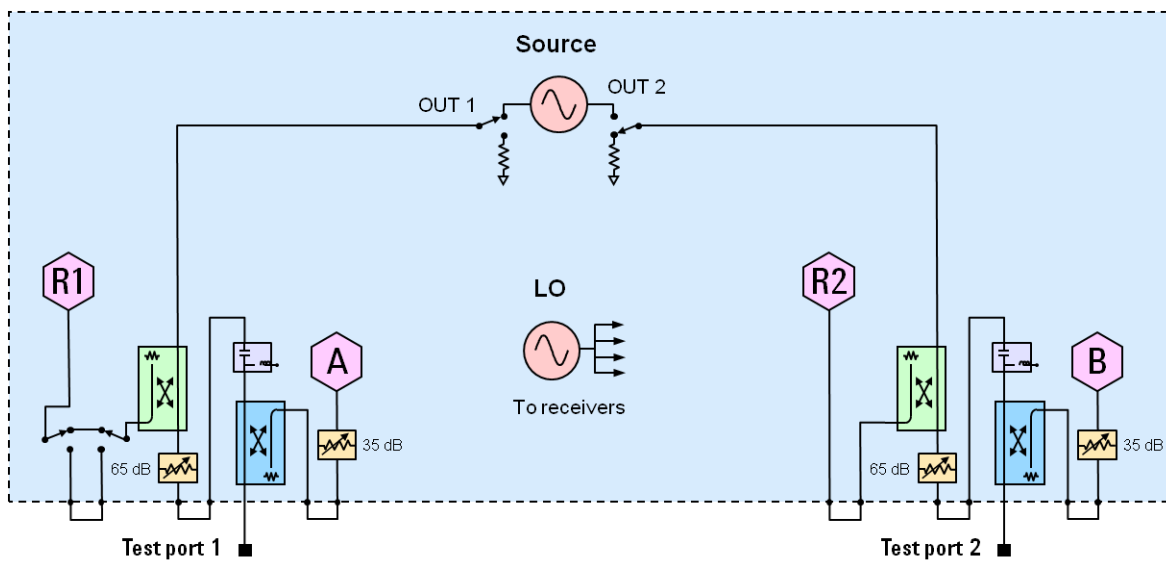

Figure 5. N5221B and N5222B Option 219

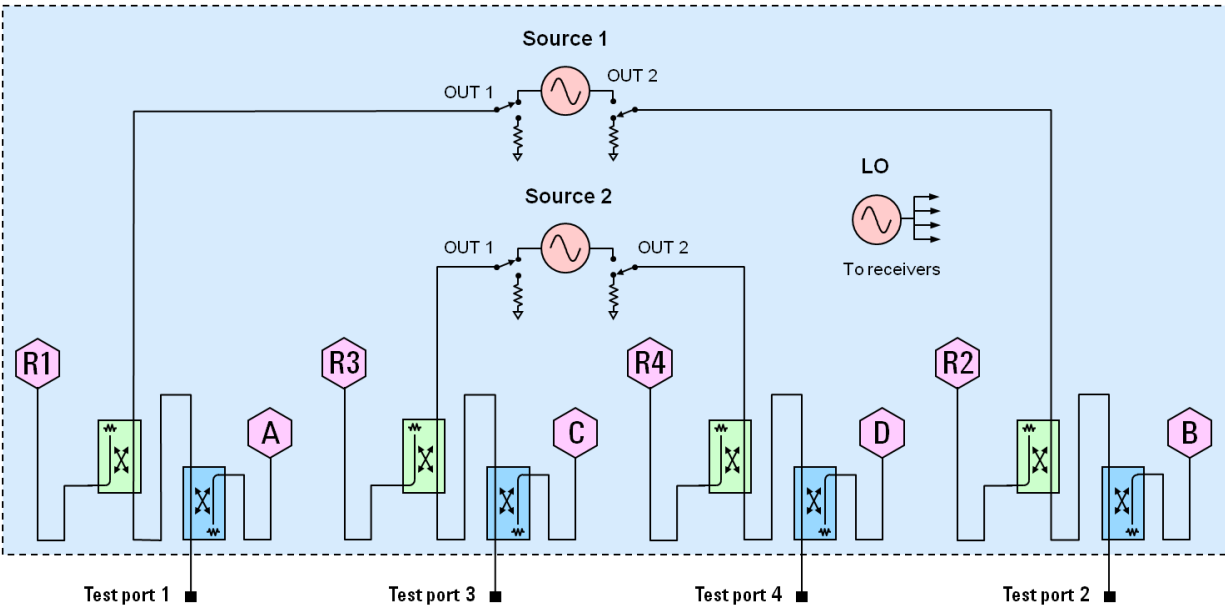

Figure 6. N5221B and N5222B Option 400 (4-port base model)

To base model, adds front-panel jumpers and R1 receiver switch

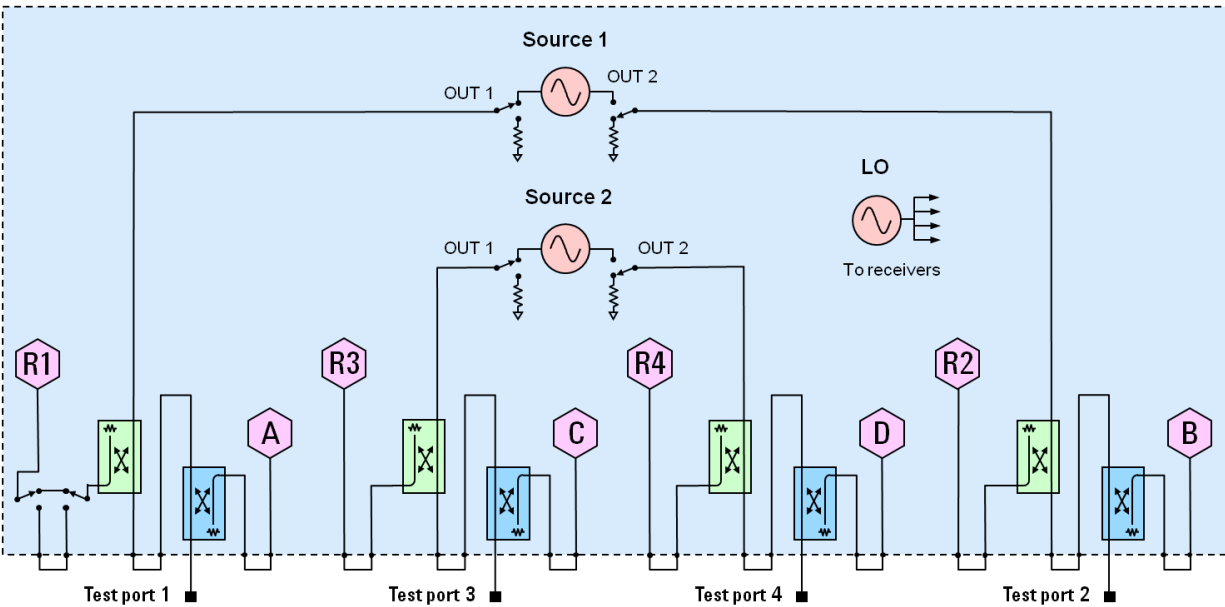

Figure 7. N5221B and N5222B Option 401

To base model, adds front-panel jumpers, R1 receiver switch, and source and receiver attenuators (extended power range).

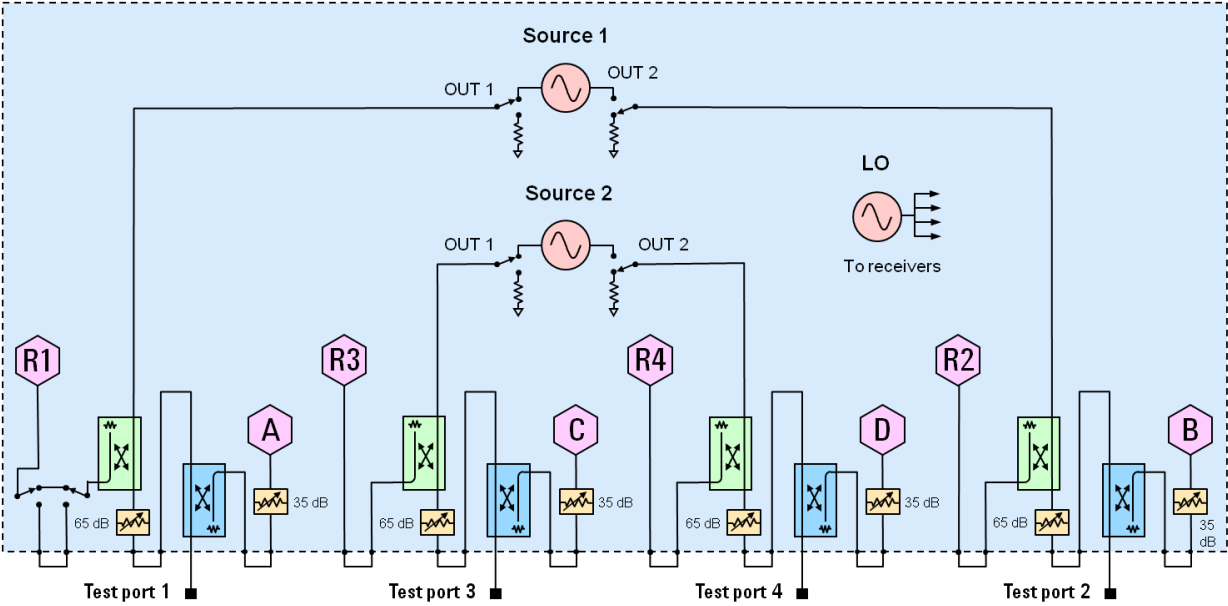

Figure 8. N5221B and N5222B Option 417

To base model, adds front-panel jumpers, R1 receiver switch, source and receiver attenuators (extended power range), and bias-tees.

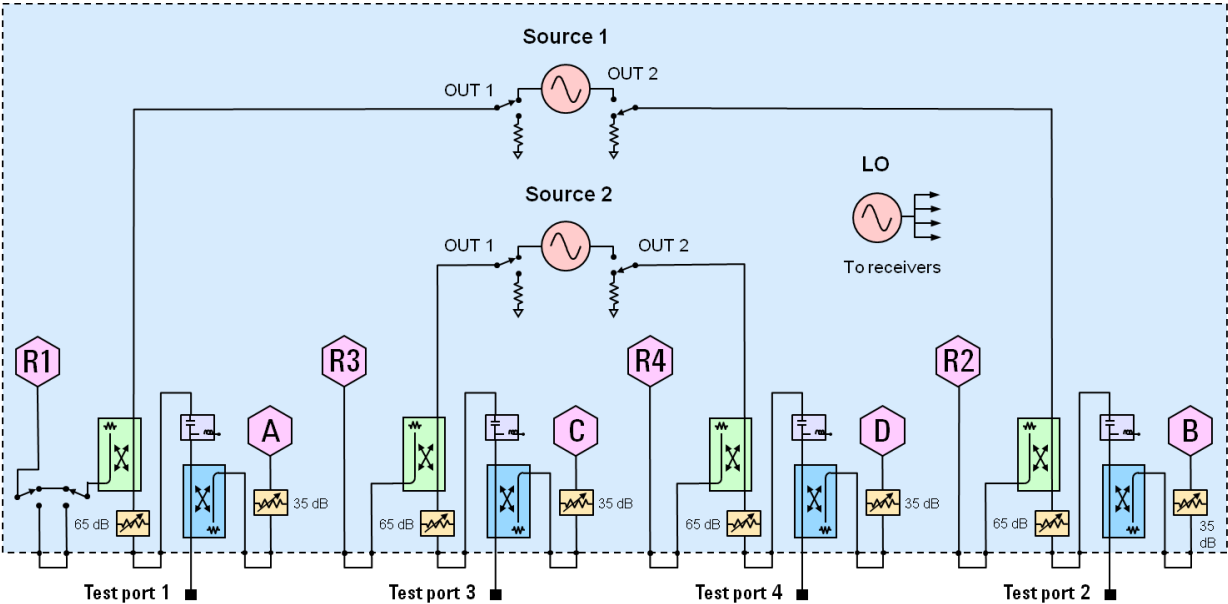

Figure 9. N5221B and N5222B Option 419

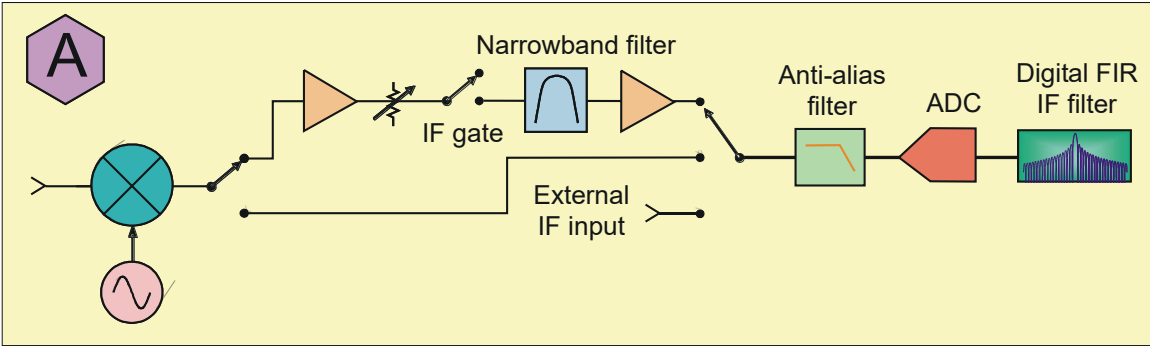

Figure 10. Receiver Block Diagram

This information is subject to change without notice.
© Keysight Technologies 2017-2026
N5221-90003
Print Date: April 1, 2026