

Banded Millimeter Wave Network Analysis

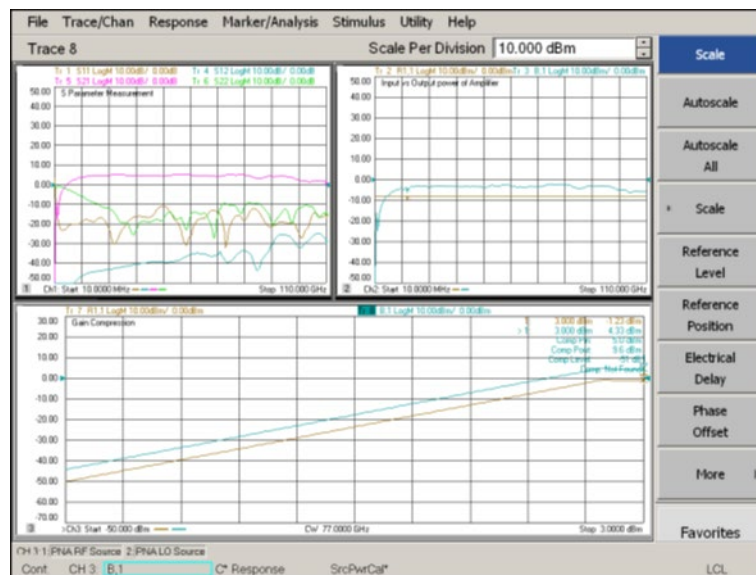
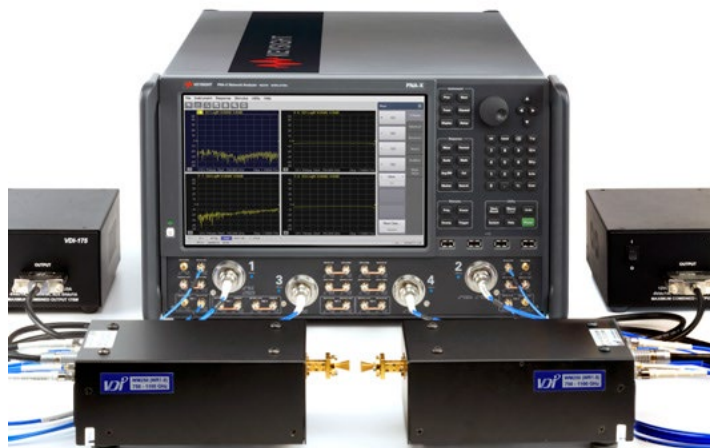

Table of Contents

Banded Measurement Solutions to 1.5 THz	3
PNA Test Set Controller Configuration	6
PNA Direct Connect Configuration	10
PNA Test Set Controller and PNA Direct Connect - Supported Configurations	14
Millimeter-wave Modules.....	16
Power Meter.....	22
USB/Thunderbolt Streamline or PXI VNA with N5252APXI Test Set Configuration	23
N5253E4 E/V/W-Band Streamline VNA Bundle Using N5252APXI Test Set Adapter ¹	27
USB/Thunderbolt Streamline or PXI VNA Direct Connect Configuration	29
N5253E5/E6/E7 V/E/W-Band Streamline VNA Bundles.....	30
Configuring a Module.....	37
Measurement Accessories.....	39
Key Web Resources	40
Confidently Covered by Keysight Services	40

Banded Measurement Solutions to 1.5 THz

Keysight offers a variety of banded millimeter-wave solutions that enable Keysight network analyzers to make component measurements up to 1.5 THz. These four solutions are easily configurable with frequency extenders from Virginia Diodes Inc. Supported solutions through Keysight may be configured with or without a test set controller, depending on the measurements required and the frequency extenders being used.

High performance solutions with PNAs

1. **PNA test set controller configuration:**
N522xB/4xB PNA/PNA-X with N5292A test set and N5256/62 frequency extenders
2. **PNA direct connect configuration:**
N522xB/4xB PNA/PNA-X with N5256/62 frequency extenders

Affordable solutions with Streamline or PXI VNAs

For higher measurement performance, frequency offset or other measurement applications, the PNA/-X based banded configuration is required.

3. **USB/Thunderbolt Streamline or PXI VNA with N5252APXI test set configuration:**
P93xxA/B and P50xxA/B Streamline VNA or M937xA/M980xA PXI-VNA with N5262BW frequency extenders and N5252APXI test set (frequency extender adapter) up to WR2.2 bands (P937xA or M937xA can be used up to D-band).
4. **USB/Thunderbolt Streamline or PXI VNA direct connect configuration:**
P93xxA/B and P50xxA/B Streamline VNA or M937xA/M980xA PXI-VNA with N5252AW frequency extenders for V, E, W and D bands

Supported measurement capability

You can make S-parameters, power measurement and sweep ⁸, and antenna measurements with both test set controller and direct control configurations. This table is a summary of available measurement application software. (S93xxxB/S94xxxB that are not on this list are not supported.)

VNA		N522xB PNA/N524xB PNA-X		P93xxA/B and P50xxA/B Streamline VNA			M937xA/M980xA PXI-VNA		
Frequency extender		N5256XXxx, N5262AWxx/BWxx		N5262BWxx		N5252AWxx	N5262BWxx		N5252AWxx
Supported bands		Up to 1.5 THz	Up to 1.5 THz		Up to WR3.4 ⁷	V,E,W and D bands only		Up to WR3.4 ⁷	V,E,W and D bands only
Application description	Application software product	PNA Test set controller configuration	PNA Direct connect configuration	Application software product	Streamline or PXI VNA with N5252APXI test set configuration	Streamline or PXI VNA direct connect configuration	Application software product	Streamline or PXI VNA with N5252APXI test set configuration	Streamline or PXI VNA direct connect configuration
Automatic fixture removal	S93007B	Yes ²	No	S97007B	Yes	Yes	S95007B	Yes	Yes
Time domain analysis	S93010B	Yes	Yes	S97010B	Yes	Yes	S95010B	Yes	Yes
Basic pulsed-RF measurements	S93025B ³	Yes	Yes	S97025B ³	Yes ⁶	Yes ⁶	S95025B ³	Yes ⁶	Yes ⁶
Advanced pulsed-RF measurements	S93026B ^{3,4}	Yes	Yes	N/A	No	No	N/A	No	No
Frequency-offset measurements	S93080B	Yes	No	N/A	No	No	N/A	No	No
Scalar mixer/converter measurements	S93082B	Yes	No	S97082B	No	No	S95082B	No	No
Vector mixer/converter measurements	S93083B	Yes ¹⁰	No	S97083B	No	No	S95083B	No	No
Intermodulation Distortion	S93087B	No ⁵	No	S97087B	No	No	S95087B	No	No
Spectrum analysis up to 90 GHz	S930909B	Yes	No	N/A	No	No	N/A	No	No
Spectrum analysis up to 125 GHz	S93093B	Yes	No	N/A	No	No	N/A	No	No
Spectrum analysis beyond 125 GHz	S93094B	Yes	No	N/A	No	No	N/A	No	No
Fast CW mode	S93118B	Yes	No	N/A	No	No	N/A	No	No
True mode stimulus	S93460B	Yes	No	S97460B	No	No	S95460B	No	No
Materials Measurements	N1500A	Yes	Yes	N1500A	Yes	Yes	N1500A	Yes	Yes
DMX limit assistant	S94602B	Yes	Yes	S94602B	Yes	Yes	S94602B	Yes	Yes
Operation with N5252AW /N5262BW frequency extenders	N/A	N/A	N/A	S97560B	Required ⁹	Required ⁹	S95560B	Required ⁹	Required ⁹

- S9xxxxBs that are not on this list are not supported.
- Band pass mode only.
- Pulse requires hardware Options 021 and 022 on the PNA or PNA-X and Option 021 on the Streamline or PXI VNA.
- S93026B limited to wideband pulse.
- IMD measurement may be done with S9309xB when using IMD module with PNA test set controller configuration.
- Available only with M980xA or P50xxA. (Not available with M937xA or P937xA).
- M937xA and P937xA can be used in D-band (WR06) or lower frequency bands only.
- When PNA-X with a built-in combiner is used, pulse and RF power leveling are available with the rear panel switched outputs; otherwise the front panel connection is required for pulse and RF power leveling.
- The software is not required for the use with P937xA or M937xA.
- Use a known mixer and information about the delay of the mixer.

Measurement performance comparison for WR15 to WR2.2 bands

VDI frequency extenders¹

Waveguide band	Frequency coverage (GHz)		Test Port Power (dBm typical)	Limit (estimate, dBm, damage)		N522xB PNA / N524xB PNA-X with N5262BWxx		P50xxA/B Streamline VNA / M980xA PXI VNA with N5252AWxx ³ or N5262BWxx with N5252APXI				P93xxA/B Streamline VNA / M937xA PXI VNA with N5252AWxx ³ or N5262BWxx with N5252APXI					
	Standard	Extended ²		Directivity (dB)	Dynamic range (BW = 10 Hz, dB)		Stability		Dynamic range (BW = 10 Hz, dB)		Stability		Dynamic range (BW = 10 Hz, dB)		Stability		
					Typical	Minimum	Magnitude (± dB)	Phase (± deg)	Typical	Minimum	Magnitude (± dB)	Phase (± deg)	Typical	Minimum	Magnitude (± dB)	Phase (± deg)	
WR15	50-75	47-77	13	30	30	120	110	0.1	1.5	110	100	0.15	2	105	95	0.15	2
WR15-P	50-75	-	13	30	30	-	-	-	-	105	95	0.15	2	105	95	0.15	2
WR12	60-90	55-95	18	30	30	120	110	0.1	1.5	110	100	0.15	2	105	95	0.15	2
WR12 SE Option	60-90	55-90	13	30	30	120	110	0.1	1.5	110	100	0.15	2	105	95	0.15	2
WR12-P	60-90	-	13	30	30	-	-	-	-	105	95	0.15	2	105	95	0.15	2
WR10	75-110	67-115	18	30	30	120	110	0.1	1.5	110	100	0.15	2	105	95	0.15	2
WR10 SE Option	75-110	67-110	-1	20	30	120	110	0.1	1.5	110	100	0.15	2	105	95	0.15	2
WR10-P	75-110	-	13	20	30	-	-	-	-	105	95	0.15	2	105	95	0.15	2
WR10-P SE Option	75-110	-	-1	20	30	-	-	-	-	105	95	0.15	2	105	95	0.15	2
WR8.0	90-140	-	16	30	30	120	110	0.15	2	110	100	0.2	2.5	95	85	0.4	6
WR6.5	110-170	-	13	30	30	120	110	0.25	4	110	100	0.3	4.5	95	85	0.4	6
WR6.5-P	110-170	-	13	30	30	-	-	-	-	95	85	0.4	6	95	85	0.4	6
WR5.1	140-220	-	6	30	30	120	110	0.25	4	110	100	0.3	4.5	N/A	N/A	N/A	N/A
WR4.3	170-260	-	4	28	30	115	110	0.3	4	110	100	0.35	4.5	N/A	N/A	N/A	N/A
WR3.4	220-330	-	1	26	30	115	105	0.3	6	110	100	0.35	6.5	N/A	N/A	N/A	N/A
WR2.2	330-500	325-500	-3	10	10	110	100	0.5	6	105	95	0.6	7	N/A	N/A	N/A	N/A

1. Please refer to the VDI web page at <https://www.vadiodes.com/en/products/vector-network-analyzer-extension-modules> for specification tables, product manuals, mechanical drawings and the other information and also for the measurement performance in the other bands.
2. N5252AWxx (WRxx-P) is available for WR15, WR12, WR10, and WR6.5 only. Extended Frequency coverage not specified for this configuration.
3. Standard VDI VNA extension modules (N5262BWxx) can be used with P50xxA/B/M980xA/P937xA/B/M937xA/B with N5252APXI adapter module.

PNA Test Set Controller Configuration



Key features

- Uses the N5292A test set controller to connect banded waveguide frequency extenders to the PNA/PNA-X.
- The N5292A test set controller enables to configure a 2-port millimeter-wave system with a single source PNA.
- The N5292A test set controller enables to configure a 4-port millimeter-wave system with a dual source PNA.
- The built-in millimeter wave dialog allows users to easily switch between different waveguide band frequency extenders connected to the test set controllers.
- Supports the connection of VDI frequency extenders that cover waveguide bands from 26.5 GHz to 1.5 THz.
- The 4-port N5292A Option 400 test controllers support differential and converter measurements using the VDI frequency converters.
- Keysight test set controller with the PNA/PNA-X can be used to calibrate and control the power at the waveguide.

Test set controller based solutions performance

The test set controller based solutions offer not only the highest frequency coverage up to 1.5 THz but have also shown the best dynamic range in the industry. The following is an example of a WR2.2 frequency extender dynamic range using a PNA/PNA-X network analyzer, and a N5262A test set controller with a typical performance of 100 dB in a 10 Hz IFBW.

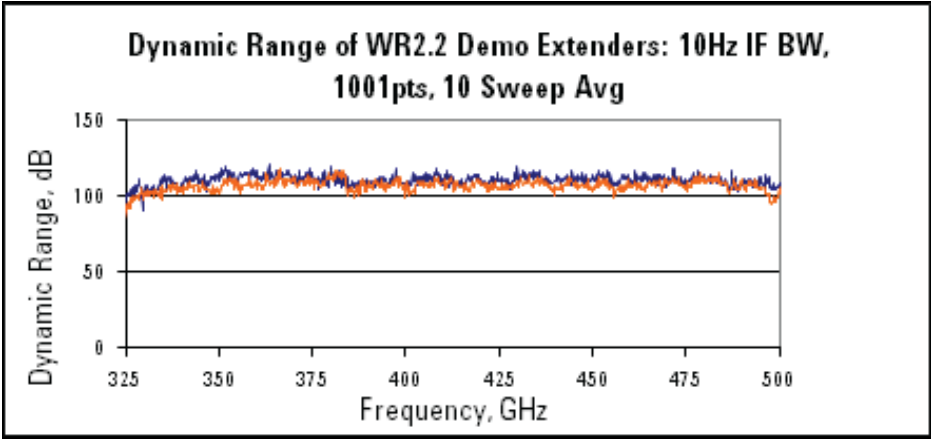

Figure 1. Dynamic range of a 325 to 500 GHz WR 2.2 VDI frequency extender

Ease-of-use

The banded millimeter-wave system uses built-in firmware, allowing you to leverage the built in software features of the PNA and PNA-X Series network analyzers. Regardless of the frequency range of your measurements, you can manually control the instrument from the front panel or use a mouse to access the simple pull-down menus. In addition, you can utilize Cal Wizard to guide you step-by-step through the most complicated of calibrations.

The banded millimeter-wave system can easily be configured using the dialogue box shown in Figure 2. Multiple system configurations can be added to the list, but only one is active at a time. Creating a banded configuration is easy, simply enter the start and stop frequencies and the multipliers for RF and LO frequency ranges (the values are located on the test head modules). Once a configuration has been added to the list, simply highlight the setup of choice and then click Activate Selected Config to apply.

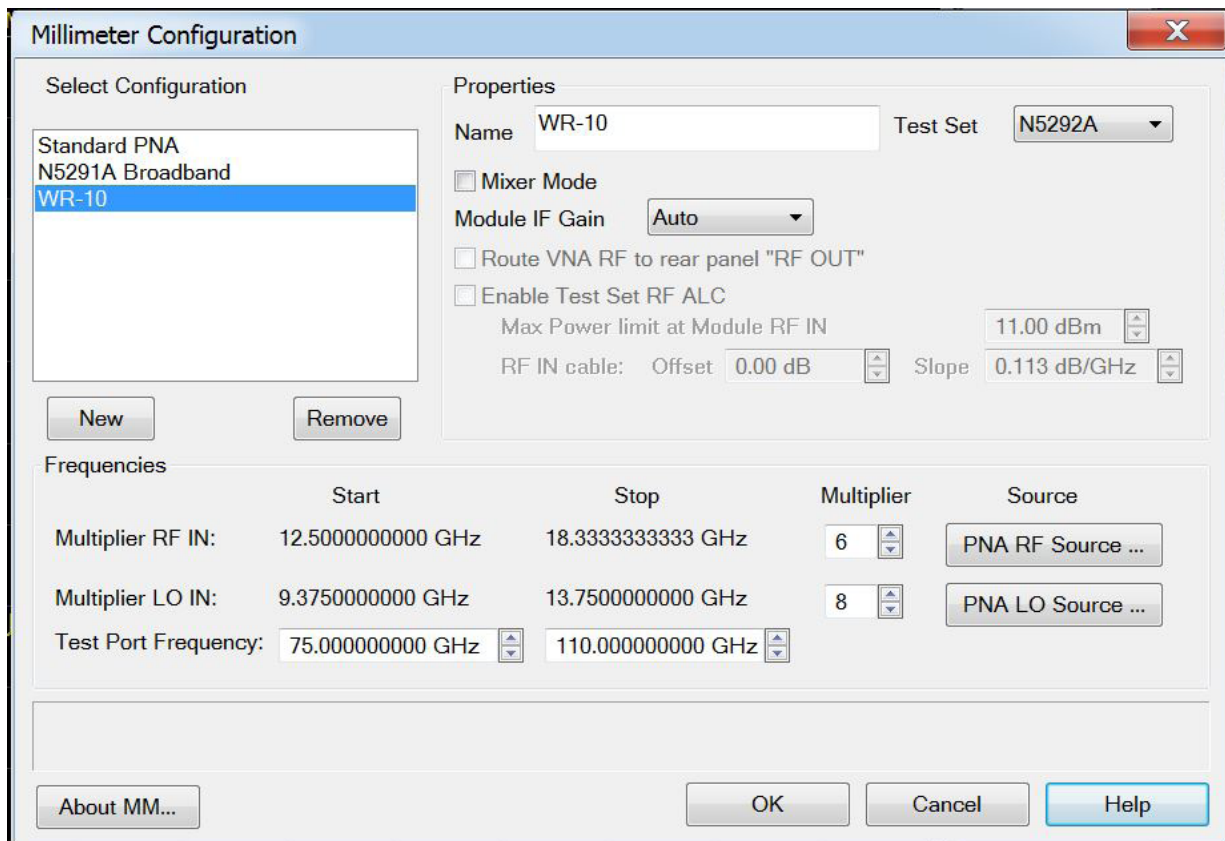
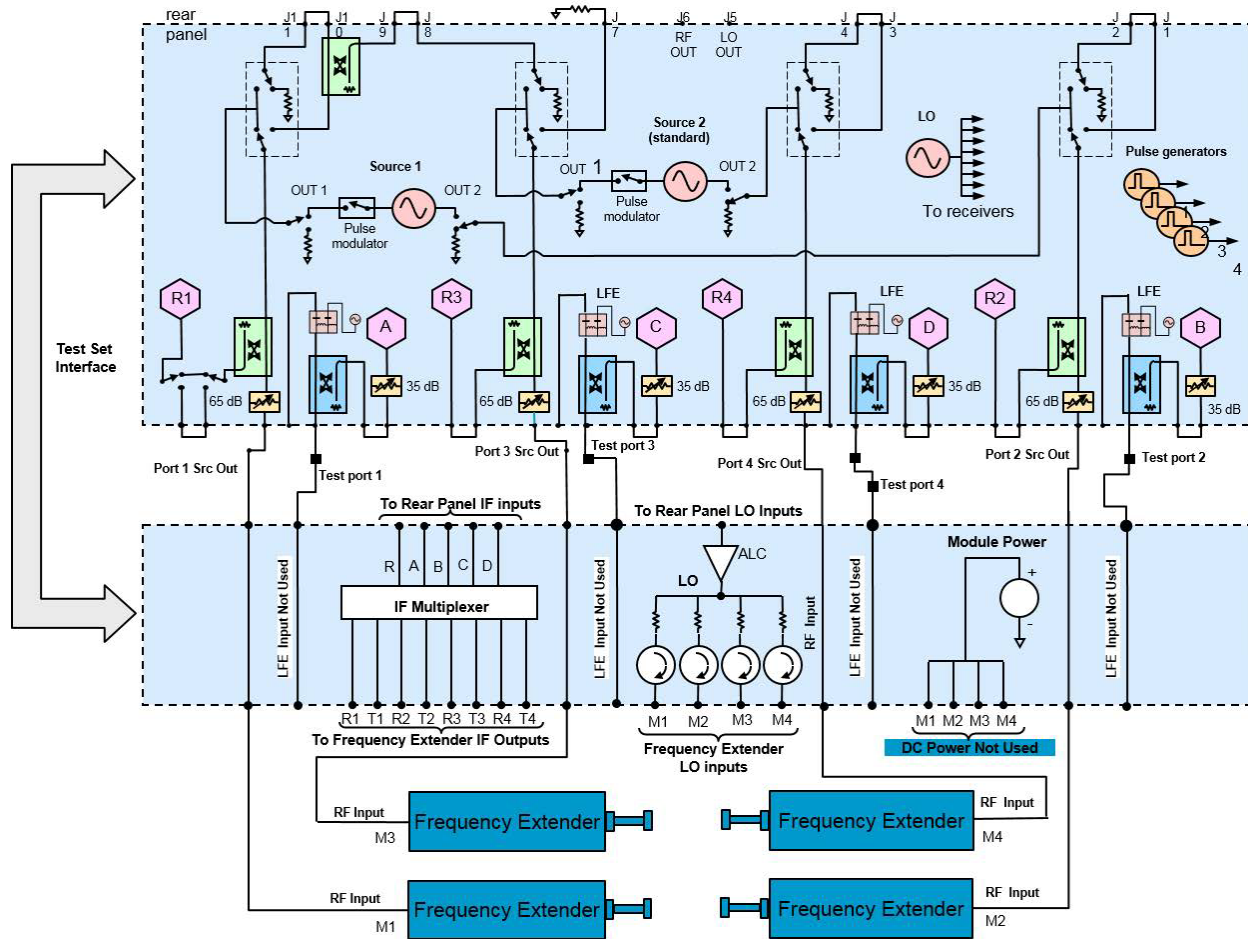

Figure 2. Millimeter-wave VNA configuration dialogue box

Test set controller based solution block diagram (N5292A)



PNA Direct Connect Configuration

These solutions do not require a millimeter-wave test set controller as they connect directly to the front panel of a dual source PNA or PNA-X. VDI frequency extenders are supported with this configuration. Here is an example of a set of VDI modules that are directly connected to a dual source PNA.



Key features

- This configuration does not require a test set controller.
- Requires a dual source PNA/PNA-X network analyzer with configurable test set option and the frequency offset mode (S93080B) to provide separate RF and LO signals to the frequency extenders.
- Supports full 2-Port S-parameter measurements within a waveguide.
- The direct connection supports power calibration and power sweep.
- Allows for the use of a higher IF frequency for test and reference signals.
- Can be driven with either a 26.5, 43.5, 50, or 70 GHz PNA/PNA-X.
- A macro which simplifies the setup of the frequency offset mode can be downloaded from this page. <https://www.keysight.com/us/en/lib/software-detail/computer-software/pna-service-applications.html>.

The direct connection configuration is currently supported using the frequency offset mode of the PNA/PNA-X and requires at least two sources to be able to do complete 2-port S-parameter measurements. The RF signal for the frequency extenders are supplied via the PNA/PNA-X port 1 and port 2 while the LO is supplied with the second source that drives the PNA/PNA-X ports 3 and 4. With this hardware configuration, the frequency offset mode can be used to set the RF source to sweep the frequency range of the waveguide band while the LO sweeps the mixers in the extenders to produce the IF signals required to make S-parameter measurements.

Key performance

Calibration technology is built into the PNA/PNA-X that enables the most accurate measurements. The following are a few of the performance characteristics of the system. Figure 3 is a demonstration of the achievable stability of this system; it shows the vector magnitude stability of a 500 to 750 GHz solution over a period of 24 hours under typical laboratory conditions of 25 °C.

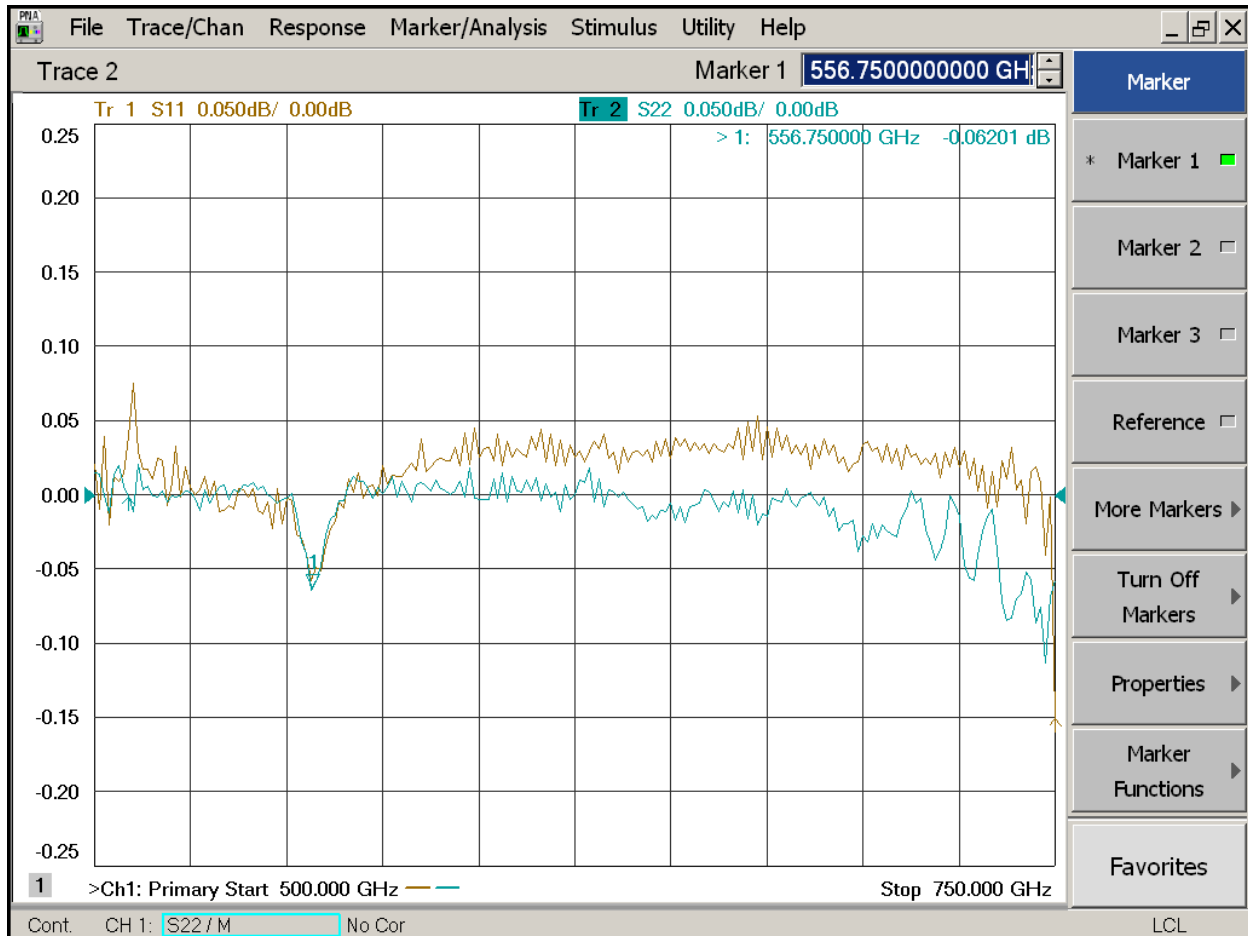

Figure 3. Typical drift performance of the PNA/PNA-X solution at 500 to 750 GHz with Virginia Diodes frequency extenders

Notice the excellent performance of less than 0.15 dB of both the short terminated ports relative to memory over a period of 24 hours. The key performance characteristic is the excellent dynamic range as illustrated by the 500 to 750 GHz.

500 GHz - 750 GHz WR1.5 Dynamic Range

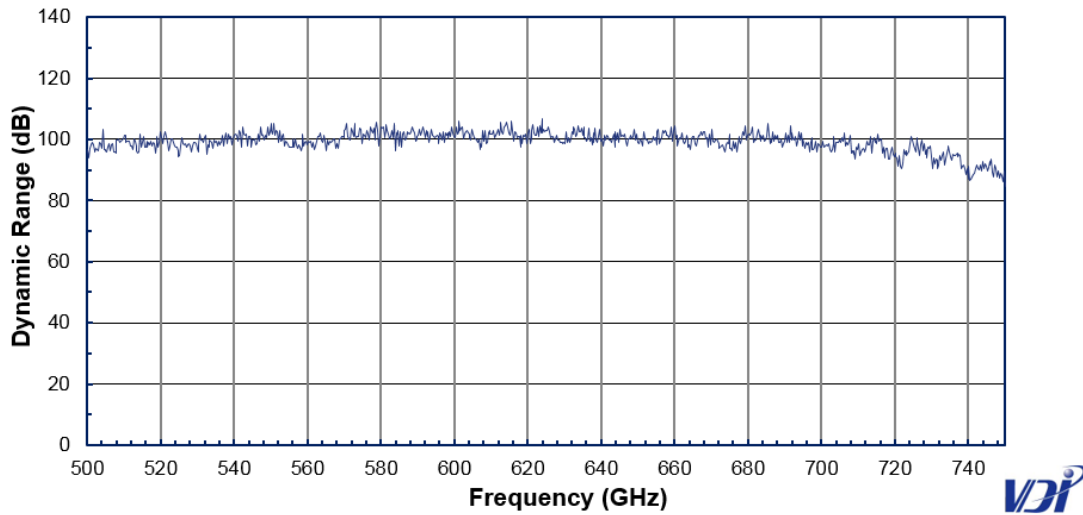
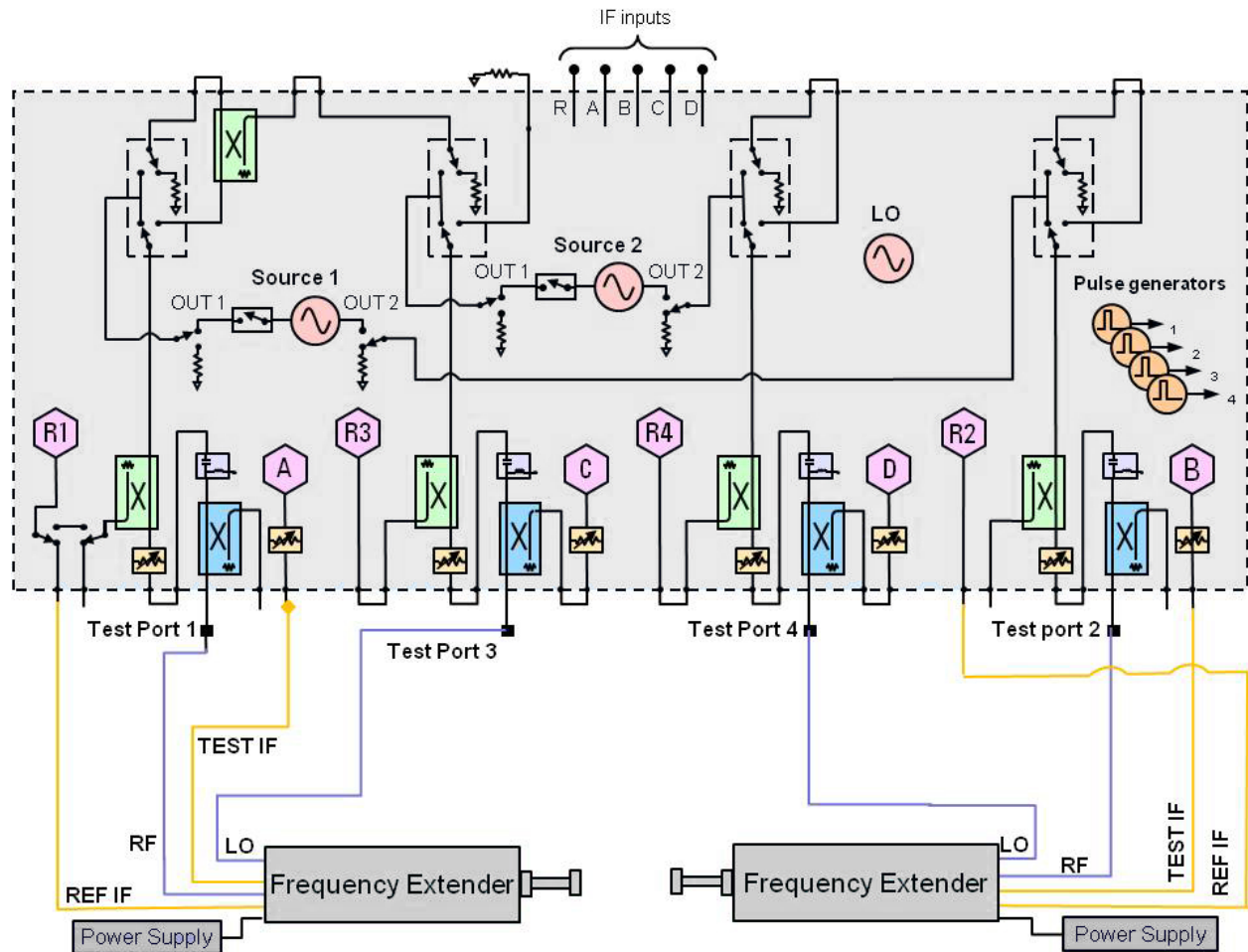

Figure 4. WR1.5 Dynamic range measurements VDI frequency extenders with a PNA-X

This solution provides unsurpassed dynamic range performance as shown in the Figure 4 plot of a 500 to 750 GHz dynamic range measurement using a direct connection of VDI extenders to a PNA/PNA-X. Note the typical performance is around 100 dB of dynamic range.

Direct connect solution block diagram

This configuration of the PNA/PNA-X with frequency extenders offers the ability to directly connect frequency extenders to a 4-port PNA/PNA-X or a 2-port PNA-X with a second source. This enables vector network analysis measurements up to 1.5 THz.



PNA Test Set Controller and PNA Direct Connect - Supported Configurations

Configuration of a banded solution is similar to configuration of a single sweep solution using separate components. With the support of several frequency extenders and vector network analyzer options, the banded solutions, offer industry leading flexibility and extensibility for measurements to 1.5 THz.

To configure hardware for a particular solution select the following components:

- PNA or PNA-X network analyzer configured to support either a test set controller or direct connection of the frequency extenders.
- 2- or 4-port millimeter test set controller, not required for direct connection. See page 4 for Supported measurement capability.
- Frequency extenders for the frequency coverage required, see pages 15 to 20 for VDI extenders (Refer to Configuring a module on page 36).
- Calibration kit for the frequency coverage required, see page 19 (VDI Cal kits).

Supported PNA and PNA-X configurations for banded waveguide

Product model and description	Minimum option required for N5292A test set controller connection	Minimum option required for direct connection
N5222/4/5/7B 2-port PNA Network Analyzer	Options 2xx (excluding 200 and 210), and 020	Unsupported
N5222/4/5/7B 4-port PNA Network Analyzer	Options 4xx (excluding 400 and 410), and 020	Option 401, 405, 417, 419 or 420 and S93080B
N5242/4/5/7B 2-port PNA-X Network Analyzer	Options 2xx and 020	Option 22x and S93080B
N5242/4/5/7B 4-port PNA-X Network Analyzer	Options 4xx and 020	Option 4xx and S93080B

Millimeter-wave test set controllers for banded configuration

N5292A-200 2-Port millimeter-wave test set controller ¹

N5292A-222	Interconnect Kit for 2 Port Test Set and 2 Port VNA with 3.5 mm Ports
N5292A-224	Interconnect Kit for 2 Port Test Set and 2 Port VNA with 2.4 mm Ports
N5292A-242	Interconnect Kit for 2 Port Test Set and 4 Port VNA with 3.5 mm Ports
N5292A-244	Interconnect Kit for 2 Port Test Set and 4 Port VNA with 2.4 mm Ports
N5290A304	Cable Adapter for VDI Frequency Extenders

N5292A-400 4-Port millimeter-wave test set controller ¹

N5292A-422	Interconnect Kit for 4 Port Test Set and 2 Port VNA with 3.5 mm Ports
N5292A-424	Interconnect Kit for 4 Port Test Set and 2 Port VNA with 2.4 mm Ports
N5292A-442	Interconnect Kit for 4 Port Test Set and 4 Port VNA with 3.5 mm Ports
N5292A-444	Interconnect Kit for 4 Port Test Set and 4 Port VNA with 2.4 mm Ports
N5290A304	Cable Adapter for VDI Frequency Extenders



1. The N5290A304 interface cable is required for each VDI module for both the 2- and 4-port N5292A. This cable adapter includes a 1.2 m length cable with an interface to the N5292A and 3.5 mm (m) connectors for the RF, LO and IF connection to the frequency extenders. If you need longer than 1.2 m, you can use an N5260/2AKCBL cable kit and four 3.5mm f-f adapters as the cable extension of the N5290A304.

Please refer to the “*Millimeter Wave Network Analyzer (N5290A/91A) – Configuration Guide*”, literature number: 5992-2179EN, for more details and required interconnect options to connect the N5292A to the PNA and PNA-X network analyzers.

Module types

- Transmission/reflection modules
 - TxRx modules (VDI) that have both a receiver and a transmitter and can perform both transmission and reflection measurements.
- Transmitter modules
 - TxRef modules (VDI) that have a transmitter source and a reference output.
- Receiver-only modules
 - Rx modules (VDI) that only have a receiver, and require a transmission/reflection module or a TxRef module to perform transmission measurements. Rx modules cannot perform reflection measurements.

Millimeter-wave Modules

VDI modules and accessories

Several modules are available and other special options may be configured on request. Select the appropriate quantity of modules required for the measurement set up. To request a specially configured test module, contact your local Keysight sales representative.

Cable sets can be purchased with modules. See cable options section.

Transmission/reflection mini-modules (Virginia Diodes VNAX models)

Waveguide flange	Frequency GHz	Standard transmission reflection modules	Transmission reflection modules with 0 to 30 dB micrometer driven attenuator
WR28	26.5 to 40	N5262BW28-STD	N5262BW28-001
WR19	40 to 60	N5262BW19-STD	N5262BW19-001
WR15 ¹	47 to 77	N5262BW15-STD	N5262BW15-001
WR12 ^{1,2}	55 to 95	N5262BW12-STD	N5262BW12-001
WR10 ^{1,2}	67 to 115	N5262BW10-STD	N5262BW10-001
WR8.0	90 to 140	N5262BW08-STD	N5262BW08-001
WR6.5	110 to 170	N5262BW06-STD	N5262BW06-001
WR5.1	140 to 220	N5262BW05-STD	N5262BW05-001
WR4.3	170 to 260	N5262BW04-STD	N5262BW04-001
WR3.4	220 to 330	N5262BW03-STD	N5262BW03-001
WR2.8	260 to 400	N5262BW2B-STD	N5262BW2B-001
WR2.2	330 to 500	N5262BW02-STD	N5262BW02-001
WR1.5	500 to 750	N5262BW1B-STD	N5262BW1B-001
WR1.0	750 to 1100	N5262BW01-STD	N/A

- A power supply is included with each module ordered. N5262BPSU Power Supply for VNAX SAX SGX CCU CCD mini modules is available for purchase as a spare power supply.
- All modules are compatible with PNA/PNA-X or test set controller and have cable options for direct connection or test set connections.
- RF/LO input power options
 - Option 120: Require +10 dBm at the module input. Recommended for use with 1.2m cable set.
 - Option 500: Require +2 dBm at the module input. Recommended for use with 5 m cable set. The RF and LO test set power level is +10 dBm. If option 500 modules are connected using 1.2 m cables, an 8 to 10 dB attenuator must be placed on each RF and LO cable connected to the modules; otherwise the VNA port power driving the RF and LO must be set to the nominal +2 dBm.
- Cable set options
 - Cable sets are available for purchase with cable options of the modules. Refer to Section, Configuring a module: Ordering a VDI VNAX mini-module, N526xBxx cable options on page 37.

1. TxRx Mini VNAX modules with extended frequency range.

- These special options are also available.
 - N5262BW10-DS0³ Dual source for IMD, WR10+, 67 to 115 GHz
 - N5262BW10-DS1³ Dual source for IMD with 0 to 30 dB attenuator WR10+, 67 to 115 GHz
 - N5262BW10-SE0 Function-restricted option, TPP< 0 dBm, Maximum Frequency < 110 GHz
 - N5262BW10-SE1 Function-restricted option, TPP< 0 dBm, Maximum Frequency < 110 GHz with 0 to 30 dB attenuator
 - N5262BW12-DS0³ Dual Source module for IMD WR12+ 55 to 95 GHz
 - N5262BW12-DS1³ Dual Source for IMD with 0 to 30 dB attenuator WR12+ 55 to 95 GHz
 - N5262BW12-SE0 Function-restricted option, 60 to 90 GHz < 15 dBm
 - N5262BW12-SE1 Function-restricted option, 60 to 90 GHz < 15 dBm with 0 to 30 dB attenuator
- Recommend to use with a dual source PNA/PNA-X, an N5292A-400 test set controller and S9309xB Spectrum Analysis application software for simple IMD measurements.

Transmission/reflection mini-modules with wideband modulation signal input (Virginia Diodes VNAX models)

Waveguide flange	Frequency GHz	Standard transmission reflection modules	Transmission reflection modules with 0 to 30 dB micrometer driven attenuator
WR10 ¹	67 to 115	N5262CW10-STD	N5262CW10-001
WR6.5	110 to 170	N5262CW06-STD	N5262CW06-001
WR4.3	170 to 260	N5262CW04-STD	N5262CW04-001
WR3.4	220 to 330	N5262CW03-STD	N5262CW03-001

The module consists of the N5262BW module and a waveguide connector for modulation signal input. The notes about the power supply, cable options, RF/LO input power options and cable set options for the N5262BWxx are also applicable to these modules. (Refer to [Technical Overview, 6G Vector Component Analysis, 3123-1405EN](#)) and the [N5262CWxx user's guide \(N5260-90086\)](#) for more information.)

- TxRx Mini VNAX modules with extended frequency range.

Transmission/reflection modules (Virginia Diodes VNAX-LG models)

Waveguide flange	Frequency GHz	Standard transmission/reflection modules	Transmission/reflection modules with 25 dB mechanical attenuator
WR0.65	1100 to 1500	N5262AW065-700	No Attenuator Option

- Each product number includes a single frequency extender that supports all PNA/PNA-X and test sets.
- A power supply is included with each module ordered. N5262APSU Power Supply for VDI Large Modules is available for purchase as a spare power supply.
- For full 2-Port S-parameter measurements order quantity 2 of the Tx/Rx modules listed above.

Transmitter and reference receiver modules (Virginia Diodes VNAX models)

Waveguide flange	Frequency GHz	Transmitter module	Transmitter/reference receiver modules with 0 to 30 dB attenuator
WR15 ¹	47 to 77	N5262BT15-STD	N5262BT15-001
WR12 ¹	55 to 95	N5262BT12-STD	N5262BT12-001
WR10 ¹	67 to 115	N5262BT10-STD	N5262BT10-001
WR8.0	90 to 140	N5262BT08-STD	N5262BT08-001

Waveguide flange	Frequency GHz	Transmitter module	Transmitter/reference receiver modules with 0 to 30 dB attenuator
WR6.5	110 to 170	N5262BT06-STD	N5262BT06-001
WR5.1	140 to 220	N5262BT05-STD	N5262BT05-001
WR4.3	170 to 260	N5262BT04-STD	N5262BT04-001
WR3.4	220 to 330	N5262BT03-STD	N5262BT03-001
WR2.2	330 to 500	N5262BT02-STD	N5262BT02-001
WR1.5	500 to 750	N5262BT1B-STD	N5262BT1B-001
WR1.0	750 to 1100	N5262BT01-STD	N5262BT01-001

1. We may be able to provide the modules for some other bands. Please check with your Keysight sales representative.

Receiver mini-modules (Virginia Diodes VNAX models)

Waveguide flange	Frequency GHz	High sensitivity receive only module with external fixed attenuator	High sensitivity dual receiver for antenna measurements
WR19	40 to 60	Not available	N5262DR19-STD
WR15 ¹	47 to 77	N5262BR15-001	N5262DR15-STD
WR12 ¹	55 to 95	N5262BR12-001	N5262DR12-STD
WR10 ¹	67 to 115	N5262BR10-001	N5262DR10-STD
WR8.0	90 to 140	N5262BR08-001	N5262DR08-STD
WR6.5	110 to 170	N5262BR06-001	N5262DR06-STD
WR5.1	140 to 220	N5262BR05-001	N5262DR05-STD
WR4.3	170 to 260	N5262BR04-001	N5262DR04-STD
WR3.4	220 to 330	N5262BR03-001	N5262DR03-STD
WR2.8	260 to 400	N5262BR2B-001	N5262DR2B-STD
WR2.2	330 to 500	N5262BR02-001	N5262DR02-STD
WR1.5	500 to 750	N5262BR1B-001	N5262DR1B-STD
WR1.0	750 to 1100	N5262BR01-001	N5262DR01-STD

- A power supply is included with each module ordered. N5262BPSU Power Supply for VNAX SAX SGX CCU CCD mini modules is available for purchase as a spare power supply.
- All modules are compatible with PNA/PNA-X or test set controller and have cable options for direct connection or test set connections.
- RF/LO input power options
 - Option 120: Require +10 dBm at the module input. Recommended for use with 1.2m cable set.
 - Option 500: Require +2 dBm at the module input. Recommended for use with 5 m cable set. The RF and LO test set power level is +10 dBm. If option 500 modules are connected using 1.2 m cables, an 8 to 10 dB attenuator must be placed on each RF and LO cable connected to the modules; otherwise the VNA port power driving the RF and LO must be set to the nominal +2 dBm.
- Cable sets options
 - Cable sets are available for purchase with cable options of the modules. Refer to Section, Configuring a module: Ordering a VDI VNAX mini-module, N526xBxx cable options on page 40.

1. TxRx Mini VNAX modules with extended frequency range.

For more information on VDI mini modules, please refer to the product note, “N5262BWxx, N5262BTxx, and N5262BRxx Mini VNA Extension Modules,” N5262-90002.

Receiver modules (Virginia Diodes VNAX-LG models)

Waveguide flange	Frequency GHz	Standard receiver only modules	High sensitivity receive only module with external fixed attenuator
WR0.65	1100 to 1500	N5262AR065-700	N5262AR065-701

- Each product number includes a single frequency extender that supports all PNA/PNA-X and test sets.
- A power supply is included with each module ordered. N5262APSU Power Supply for VDI Large Modules is available for purchase as a spare power supply.
- The receiver module requires a transmission module.

Dimensions for waveguide transmission/reflection modules (Virginia Diodes Inc.)

Module	Width	Length	Height
Standard	5.0 inches	15.275 inches including waveguide, WR1.5 to WR15	3.5 inches (feet adjust +1.25 inches)
		10.25 inches including waveguide WR1.0	
Mini-modules	3.0 inches	8.5 inches, N5262BWxx and N5262BTxx	1.5 inches (feet adjust +0.75 inches)
	3.0 inches	3.75 inches, N5262BRxx	1.5 inches (feet adjust +0.75 inches)

Calibration kits (Virginia Diodes Inc.)

Waveguide flange	Frequency GHz	Calibration kit
WR28	26.5 to 40	N5260AC28
WR19	40 to 60	N5262AC19
WR15	50 to 75	N5262AC15
WR12	60 to 90	N5262AC12
WR10	75 to 110	N5262AC10
WR8.0	90 to 140	N5262AC08
WR6.5	110 to 170	N5262AC06
WR5.1	140 to 220	N5262AC05
WR4.3	170 to 260	N5262AC04
WR3.4	220 to 330	N5262AC03
WR2.8	260 to 400	N5262AC28
WR2.2	330 to 500	N5262AC02
WR1.5	500 to 750	N5260AC01
WR1.0	750 to 1100	N5262AC01
WR0.65	1100 to 1500	N5262AC065

Cable Options (Virginia Diodes Inc.)

These cable sets work for both VNAX and VNAX-LG frequency extenders, and these are available for separate purchase as options of N5262AKCBL Cable kits for mm-wave systems with VDI modules.

Cable option	Description
N5260AWCBL-201	1.2 m cable set for N5262BWxx Tx/Rx modules for direct connect to 26.5 GHz PNA/PNA-X. (1 RF, 1 LO and 2 IF cables with 2.92 mm connectors)
N5260AWCBL-205	5 m cable set for N5262BWxx Tx/Rx modules for direct connect to 26.5 GHz PNA/PNA-X. (1 RF, 1 LO and 2 IF cables with 2.92 mm connectors)
N5260AWCBL-401	1.2 m cables set for N5262BWxx Tx/Rx modules for direct connect to > 43.5 GHz PNA/PNA-X. (1 RF, 1 LO and 2 IF cables with 1.85 mm connectors)
N5262AWCBL-701	1.2 m cable set for N5262AW065 Tx/Rx modules for direct connect to > 43.5 GHz PNA/PNA-X (2 RF, 1 LO and 2 IF cables with 1.85 mm connectors. One of the two RF cables is for connection to the RF-H port on the module, and it has 2.4 mm (m) on one end and 1.85mm (f) on the other end.)
N5260AW-405	5 m cables set for N5262BWxx Tx/Rx modules for direct connect to > 43.5 GHz PNA/PNA-X. (1 RF, 1 LO and 2 IF cables with 1.85 mm connectors)
N5260AWCBL-501	1.2 m cable set for N5262BWxx Tx/Rx modules to connect N5252APXI test set adapter. (1 RF, 1 LO and 2 IF cables with 2.92 mm connectors)
N5260AWCBL-505	5 m cable set for N5262BWxx Tx /Rx modules to connect N5252APXI test set adapter (1 RF, 1 LO and 2 IF cables with 2.92 mm connectors)
N5260ARCBL-201	1.2 m cable set for N5262BRxx Rx-only modules for direct connect to 26.5 GHz PNA/PNA-X. (1 LO and 1 IF cables with 2.92 mm connectors)
N5260ARCBL-205	5 m cable set for N5262BRxx Rx-only modules for direct connect to 26.5 GHz PNA/PNA-X. (1 LO and 1 IF cables with 2.92 mm connectors)
N5260ARCBL-401	1.2 m cable set for N5262BRxx Rx-only modules for direct connect to > 43.5 GHz PNA/PNA-X. (1 LO and 1 IF cables with 1.85 mm connectors)
N5260AR-405	5 m cable set for N5262BRxx Rx-only modules for direct connect to > 43.5 GHz PNA/PNA-X. (1 LO and 1 IF cables with 1.85 mm connectors)
N5260ARCBL-501	1.2 m cable set for N5262BRxx Rx-only modules to connect N5252APXI test set adapter. (1 LO and 1 IF cables with 2.92 mm connectors)
N5260ARCBL-505	5 m cable set for N5262BRxx Rx-only modules to connect N5252APXI test set adapter. (1 LO and 1 IF cables with 2.92 mm connectors)

Note:

- N5290A304 1.2m cable is required for the use with the N5292A test set.
- One end of the cables is 2.92mm (m) for the frequency extender port connection. The other end of the RF and LO cables for the PNA-PNA-X direct connect is either 2.92mm or 1.85mm female and the connector of the IF cables is either 2.92mm or 1.85mm male. The other end of the cables for the N5252APXI connection is 2.92mm male.

Waveguide designation equivalent table (supplemental information)

MIL-DTL-85/3C	IEEE Std 1785.1	Frequency range
WR-15	WM-3759	50 GHz to 75 GHz
WR-12	WM-3099	60 GHz to 90 GHz
WR-10	WM-2540	75 GHz to 110 GHz
WR-08 (WR8.0) ¹	WM-2032	90 GHz to 140 GHz
WR-06 (WR6.5) ¹	WM-1651	110 GHz to 170 GHz
WR-05 (WR5.1) ¹	WM-1295	140 GHz to 220 GHz
WR-04 (WR4.3) ¹	WM-1092	170 GHz to 260 GHz
WR-03 (WR3.4) ¹	WM-864	220 GHz to 330 GHz
WR-02 (WR2.8) ¹	WM-710	260 GHz to 400 GHz
WR-02 (WR2.2) ¹	WM-570	330 GHz to 500 GHz
WR-1.5	WM-380	500 GHz to 750 GHz
WR-1.0	WM-250	750 GHz to 1.1 THz
WR-0.65	WM-164	1.1 THz to 1.5 THz

Reference: IEEE Standard for Rectangular Metallic Waveguides and Their Interfaces for Frequencies of 110 GHz and Above — Part 1: Frequency Bands and Waveguide Dimensions.

1. VDI band designation.

Power Meter

N1913PM5B calorimetric power meter (Virginia Diodes Inc.)¹

The N1913PM5B can be controlled by a PNA/PNA-X or the N5252A for source power calibration within mm-wave frequency ranges. It can be operated manually or with supplied GUI computer software to measure the power of banded VDI mm-wave network analyzer frequency extenders or signal source frequency extension modules E8257DVxx or E8257DSxx with waveguide test ports. Tapers² are available for mm-wave frequency bands up to 1.5 THz.

Waveguide flange	Frequency [GHz]	Power meter
WR10	75 to 110	N1913PM5B N1913PM5B-701 (mandatory option)

Waveguide flange	Frequency [GHz]	Power meter
WR8.0	90 to 140	N1913PM5B-008
WR6.5	110 to 170	N1913PM5B-006
WR5.1	140 to 220	N1913PM5B-005
WR4.3	170 to 260	N1913PM5B-004
WR3.4	220 to 330	N1913PM5B-003
WR2.8	260 to 400	N1913PM5B-02B
WR2.2	325 to 500	N1913PM5B-002
WR1.5	500 to 750	N1913PM5B-01B
WR1.0	750 to 1100	N1913PM5B-001
WR0.65	1100 to 1500	N1913PM5B-065

1. It includes a power meter and a power sensor for operation 75 to 110 GHz. (This does not support other Keysight power sensors.), a USB cable for connection to PC or PNA/PNAX, a user's guide from VDI with programming instructions. It comes in a Pelican case with optional tapers in a separate pelican case for safe transportation.
2. Tapers can also be ordered as options of N9029AV99 mmwave frequency extenders accessories.



USB/Thunderbolt Streamline or PXI VNA with N5252APXI Test Set Configuration

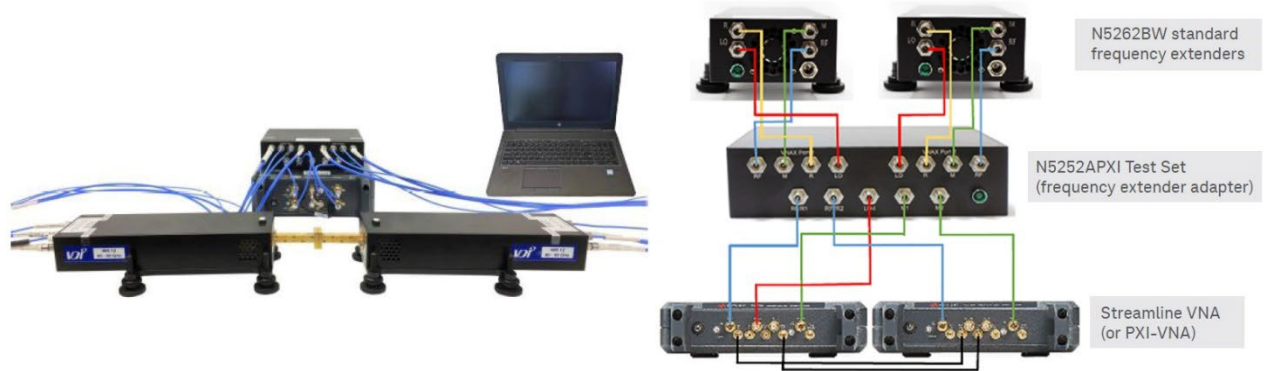

N5262BW Transmission/Reflection mini-modules (Virginia Diodes VNAX models) can be used with PXI-VNAs or Streamline VNAs with N5252APXI Test Set (Frequency Extender Adapter) from WR15 to WR2.2 bands.

Key features

- N5262BW frequency extenders can be used with the N5252APXI test set.
- More affordable than PNA-based configurations up to WR2.2 bands
- Full 2 or 4-port S-parameter measurements within a waveguide
- Configuration flexibility
 - Two 2-port VNAs or one 4-port VNA with one N5252APXI test set and a pair of N5262BW frequency extenders for 2-port configuration
 - Two 4-port Streamline VNAs or 8-port PXI-VNA configuration with two N5252APXI test sets and four N5262BW frequency extenders for 4-port configuration
- The use of the N5252APXI adapter test set allows use of 5m cable sets, available with the N5262BW frequency extenders with option 500
- Power calibration at test ports with an optional waveguide power sensor
- Small footprint

Available frequency extenders

Waveguide flange	Frequency GHz	Standard transmission reflection modules ³	Transmission reflection modules with 0 to 30 dB micrometer driven attenuator ³
WR15 ¹	47 to 77	N5262BW15-STD	N5262BW15-001
WR12 ^{1,2}	55 to 95	N5262BW12-STD	N5262BW12-001
WR10 ^{1,2}	67 to 115	N5262BW10-STD	N5262BW10-001
WR8.0	90 to 140	N5262BW08-STD	N5262BW08-001
WR6.5	110 to 170	N5262BW06-STD	N5262BW06-001
WR5.1	140 to 220	N5262BW05-STD	N5262BW05-001
WR4.3	170 to 260	N5262BW04-STD	N5262BW04-001
WR3.4	220 to 330	N5262BW03-STD	N5262BW03-001
WR2.2	330 to 500	N5262BW02-STD	N5262BW02-001

Module	Width	Length	Height
Mini-modules	3.0 inches	8.5 inches	1.5 inches (feet adjust +0.75 inches)

1. TxRx Mini VNAX modules with extended frequency range.
2. These special options are also available.
 - N5262BW10-SE0 Function-restricted option, TPP < 0 dBm, Maximum Frequency < 110 GHz
 - N5262BW10-SE1 Function-restricted option, TPP < 0 dBm, Maximum Frequency < 110 GHz with 0 to 30 dB attenuator
 - N5262BW12-SE0 Function-restricted option, 60 to 90 GHz < 15 dBm
 - N5262BW12-SE1 Function-restricted option, 60 to 90 GHz < 15 dBm with 0 to 30 dB attenuator
3. Options 120 and 501 are needed for connecting the frequency extenders and the N5252APXI test set with 1.2m cables, and options 500 and 505 are needed for connecting them with 5m cables. (RF/LO input power options. Option 120: Require +10 dBm at the module input. Recommended for use with the test set and 1.2 m cable set. Option 500: Require +2 dBm at the module input. Recommended for use with the test set and 5m cable set. If option 500 modules are connected using 1.2 m cables, an 8 to 10 dB attenuator must be placed on each RF and LO cable connected to the modules; otherwise the VNA port power driving the RF and LO must be set to the nominal +2 dBm.)

Cables

Options 120 and 501 are required for the N5262BWxx frequency extenders for connecting the N5262BWxx frequency extenders and the N5252APXI test set with 1.2m cables, and options 500 and 505 are required for connecting them with 5m cables. The five cables to connect the N5252APXI test set and the VNA(s) are included in the N5252APXI test set. The test cables for the VNA standalone use need to be purchased additionally. (Refer to the VNA configuration guide.)

N5260AWCBL cable sets are available for the purchase of spare cables for the N5262BW option 501 or 505.

Cable option	Description
N5260AWCBL-501	1.2m cable set for controller and Tx/Rx opt TST module (N5262AWCBL-501)
N5260AWCBL-505	5m cable set for controller and Tx/Rx opt TST module (N5262AWCBL-505)

Calibration kits (Virginia Diodes Inc.)

Waveguide flange	Frequency GHz	Calibration kit
WR15	50 to 75	N5262AC15
WR12	60 to 90	N5262AC12
WR10	75 to 110	N5262AC10
WR8.0	90 to 140	N5262AC08
WR6.5	110 to 170	N5262AC06
WR5.1	140 to 220	N5262AC05
WR4.3	170 to 260	N5262AC04
WR3.4	220 to 325	N5262AC03
WR2.2	325 to 500	N5262AC02

N1913PM5B Calorimetric power meter ¹

The N1913PM5B can be used for source power calibration within mw-wave frequency ranges. It can be operated manually or with supplied GUI computer software to measure the power of banded VDI frequency extenders. Tapers are also available.

Waveguide flange	Frequency [GHz]	Power meter
WR10	75 to 110	N1913PM5B

Waveguide flange	Frequency [GHz]	Waveguide taper options
WR8.0	90 to 140	N1913PM5B-008
WR6.5	110 to 170	N1913PM5B-006
WR5.1	140 to 220	N1913PM5B-005
WR4.3	170 to 260	N1913PM5B-004
WR3.4	220 to 330	N1913PM5B-003
WR2.2	325 to 500	N1913PM5B-002

1. It includes a power meter and a power sensor for operation 75 to 110 GHz. (This does not support other Keysight power sensors.), a USB cable for connection to PC or PNA/PNAX, a user's guide from VDI with programming instructions. It comes in a Pelican case with optional tapers in a separate pelican case for safe transportation.

Configurations with individual purchase

M937xA PXI-VNA based configuration	2-port	4-port
	Quantity	Quantity
M9005A PXIe chassis with Option 002	1	1
M9374A or 75A PXIe VNA (M9373A can also be used for V band)	2	4
Y1212A PXI slot blockers: qty 5	1	1
Y1213A PXI EMC filter panel kit: 5 slots	1	1
Y1242A multiport cable kit	1	3
Y1281A accessory and tool kit	1	1
M9374A-551 N-port calibrated measurement	1	1
N5262BWXX VDI VNAX frequency extenders	2	4
N5252APXI test set	1	2
N5262ACXX calibration kit or x11644A ² waveguide calibration kit for V or W band	1	1
Desktop computer	1	1

P937xA Streamline USB VNA based configuration	2-port
	Quantity
P9374A or 75A USB-VNA (P9373A can also be used for V band)	2
Y1701A with Option 001 and 101 multiple USB instruments configuration kit	1
Y1281A accessory and tool kit	1
S97551B multiple modules measurements	1
N5262BWXX VDI VNAX frequency extenders	2
N5252APXI test set	1
N5262ACXX calibration kit or x11644A ² waveguide calibration kit for V or W band	1
Laptop PC	1

M980xA PXI-VNA based configuration	2-port (configured with one 4 or 6-port PXI VNA)	2-port (configured with two 2-port PXI VNAs)	4-port
	Quantity	Quantity	Quantity
M9010A 10-slot chassis	1	1	1
IO card for desktop pc	1	1	1
Y1212A PXI slot blockers: qty 2	1	1	1
Y1213A PXI EMC filter panel kit: 5 slots x 2ea	1	1	1
M9804A with Option 400 or 600 (M9803A can also be used for V band) ¹	1	N/A	Depends on VNA cards used to configure an 8-port VNA
M9804A or higher frequency model with option 200 (M9803A can also be used for V band) ¹	N/A	2	
Y1730A-001 ³	0	1	
Y1730A-002 ³	0	0	
S95551B multiple instruments measurements	0	1	1
S95560B PXI-VNA mmWave operation with VDI frequency extenders	1	1	1
N5262BWXX VDI VNAX frequency extenders	2	2	4
N5252APXI test set	1	1	2
N5262ACXX calibration kit or x11644A ² waveguide calibration kit for V or W band	1	1	1
Desktop computer	1	1	1

1. Choose either of the VNA choices (of option 400/600 or option 200).
2. x: V or W
3. -001 when M980xA option 400 is selected, -002 when M980xAs option 200 are selected.

P50xxA/B and P93xxB Streamline VNA based configuration ⁶	2-port (configured with one 4 or 6-port Streamline VNA)	2-port (configured with two 2-port Streamline VNAs)	4-port
	Quantity	Quantity	Quantity
P5024A/B or higher frequency model with Option 400, P5024A/B with Option 600 or P9384B (P5023A/B can also be used for V band) ³	1	N/A	2 (or 1)
P5004A/B or higher frequency model with Option 200 or P9374/5/7B (P5003A/B or P9373B can also be used for V band) ³	N/A	2	0 (or 1)
11904C 2.4mm (m) to 2.92mm (f) adapters ²	0 or 4	total number of 2.4 or 1.85 mm test ports on VNAs (0, 2 or 4)	total number of 2.4 or 1.85 mm test ports on VNAs (0, 2, 4 or 8)
Y1701A-002 or 003 multiple instruments configuration kit ⁴	0	1	1
Y1701A-101 latch kit for connecting two 1-slot instruments	0	1	0
Y1701A-202 (or -102) Latch kit for connecting 2-slot (or 1-slot) and 2-slot instruments ⁵	0	0	1
S97551B multiple instruments measurements	0	1	1
S97560B Streamline VNA mmWave operation with VDI frequency extenders	1	1	1
N5262BWXX VDI VNAX frequency extenders	2	2	4
N5252APXI test set	1	1	2
N5262ACXX calibration kit or x11644A ¹ waveguide calibration kit for V or W band	1	1	1
Laptop PC	1	1	1

1. x: V or W
2. Not needed for P50x5A/B, P9375B or lower frequency models.
3. Choose either of the VNA choices of option 400/600 or option 200. For 4-port configuration with Streamline VNAs, you can't connect more than two VNAs, so if one of the two VNAs is with option 600, the other one can be one 2-port VNA; otherwise both VNAs should be P502xA/B.
4. This is not needed only when one Streamline VNA is used. Y1701A-002 is needed for two P50x4A/Bs, P9374Bs or lower frequency models. Y1701A-003 for two P9375Bs, P50x5A/Bs or higher frequency models.
5. Y1701A-102 is needed only when P500xA/B with option 200 and P502xA/B with Option 400 or 600 are connected.
6. P/N M9485-23001 (Socket, 5/16 inch) is recommended as a tool kit for P50xxA/B VNAs

For more information about the N5252APXI test set, refer to the product note, [N5252-90004](#)

For more ordering information about the PXI-VNAs and USB/Thunderbolt Streamline VNAs, refer to the configuration guides [5991-4885EN](#), [5992-3597EN](#), [5992-2823EN](#) and [3121-1254.EN](#).

N5253E4 V/E/W-Band Streamline VNA Bundle Using N5252APXI Test Set Adapter



Key features

- Affordable 2-port measurements in V, E or W-band than PNA-based banded VNA
- Standalone Streamline USB VNA P5024B allows you to make 4-port measurements up to 20 GHz
- Calibration with a furnished waveguide calibration kit
- Power calibration at test ports with an optional waveguide power sensor

Key measurement performance

- Frequency range: 50 GHz to 75 GHz (V-band), 60 GHz to 90 GHz (E-band), or 75 GHz to 110 GHz (W-band)
- Dynamic range (BW=10 Hz): 100 dB minimum/110 dB typical
- Test Port Power: +13 dBm typical
- Test Port Interface: WR-xx IEEE 1785-2a compatible with UG-387/UM

Configuration information

- One P5024B 20 GHz 4-Port Streamline Thunderbolt VNA
- One S97560B millimeter-wave operation with Streamline USB VNA
- One N5252APXI Test Set Adapter
- Two VDI N5262BWxx VNAX mini WR15, WR12 or WR10 millimeter-wave modules
- Two 5 m cable sets
- One N5262ACxx calibration kit for WR15, WR12 or WR10 (V, E or W-Band)
- Alternative items are not available for this bundle.
- A laptop pc is not included.

Optional items

Either of these two power sensors/meter combinations is required for power calibration.

Items	Description
A U8489A and an E281CS	120 GHz USB power sensor and 1.0 mm coax (f) to WR-12 waveguide adapter
An E8486A and a power meter	E-band waveguide power sensors and a power meter with USB, LAN or GPIB

USB/Thunderbolt Streamline or PXI VNA Direct Connect Configuration



Key features

- Most affordable configurations with N5252AW Frequency Extenders for V, E, W and D bands.
- Full 2 or 4-port S-parameter measurements
- Configuration flexibility
 - Two 2-port VNAs or one 4-port VNA with a pair of N5252AW frequency extenders for 2-port configuration
 - 8-port VNAs with two Streamline VNAs or multiple PXI-VNAs and two pairs of N5252AW frequency extenders for 4-port configuration
- The direct connection supports power calibration and power sweep.
- Small footprint

N5252AW Frequency Extenders for PXI-VNAs and USB/Thunderbolt Streamline VNAs

N5252AW VDI VNAX mini millimeter-wave frequency extenders for V, E, W and D bands allow you to configure your own 2 or 4-port millimeter-wave VNA system with PXI-VNAs or 2-port millimeter-wave VNA system with Streamline VNAs with individual purchase. Refer to the table on page 4 for measurements supported with the N5252AW frequency extenders. See [N5252-90003](#) Quick Start Guide for more information.

N5253E5/E6/E7 V/E/W-Band Streamline VNA Bundles



Key features

Affordable 2-port measurements in V, E or W-band than PNA-based banded VNA
Standalone Streamline USB VNA allows you to make:

- 4-port measurements up to 20 GHz (N5253E5)
- 4-port measurements up to 20 GHz and 2-port measurements up to 53 GHz (N5253E6)
- 4-port measurements up to 53 GHz (N5253E7)

Calibration with a furnished waveguide calibration kit

Power calibration at test ports with an optional waveguide power sensor

Key measurement performance

- Frequency range: 50 GHz to 75 GHz (V-band), 60 GHz to 90 GHz (E-band), or 75 GHz to 110 GHz (W-band)
- Dynamic range (BW=10 Hz): 100 dB minimum/110 dB typical
- Test Port Power: +13 dBm typical
- Test Port Interface: WR-xx IEEE 1785-2a compatible with UG-387/UM

Bundle configuration

- P5024A/B 20 GHz 4-Port Streamline USB VNA (N5253E5)
- P5004A/B 20 GHz 2-Port Streamline USB VNA and P5008A/B 53 GHz 2-Port Streamline USB VNA (N5253E6)
- P5028A/B 53 GHz 4-Port Streamline USB VNA (N5253E7)
- S97560B millimeter-wave operation with Streamline USB VNA
- S97551B multiple instrument measurements (N5253E6 only)
- Two VDI N5252AWxx VNAX mini WR15, WR12 or WR10 millimeter-wave modules
- Two 1.2 m cable sets
- One N5262ACxx calibration kit for WR15, WR12 or WR10 (V, E or W-Band)
- Alternative items are not available for these bundles.
- A laptop pc is not included.

Optional items

Either of these two power sensors/meter combinations is required for power calibration.

Items	Description
A U8489A and an E281CS	120 GHz USB power sensor and 1.0 mm coax (f) to WR-12 waveguide adapter
An E8486A and a power meter	E-band waveguide power sensors and a power meter with USB, LAN or GPIB

Optional software application ¹	Description
S97007B	Automatic Fixture Removal
S97010B	Time Domain
S97025B	Basic pulsed-RF measurements

System level calibration is not available. P50xxA Streamline VNA calibration options A6J/1A7 are available in these bundles.

1. See the configuration guide (5991-4885EN, 5992-3597EN, 5992-2823EN and 3121-1254.EN) for more available applications for the standalone use.

N5252AW frequency extenders for PXI-VNAs and Streamline VNAs for individual purchase

- N5252AW15 (50 GHz to 75 GHz)
- N5252AW12 (60 GHz to 90 GHz)
- N5252AW10 (75 GHz to 110 GHz)
- N5252AW10-SE2 (75 GHz to 110 GHz, function-restricted option, <0 dBm)
- N5252AW06 (110 GHz to 170 GHz)

N5252AWxx-201 provides a pair of frequency extenders, two sets of 1.2 meter cable sets, two power supplies, and two USB memory drives in a Pelican case. Refer to the Quick Startup Guide, [N5252-90003](#) for more information.



Figure 5. N5252AWxx-201 Contents

N5252AWxx-201 contents list

Items	Description
N5252-80002 ¹	Pair of N5252AW12 TxRx VNAX Modules, with 1.2 m cable sets (2 sets of 3), power supplies (2), and USB drives (2), in a Pelican case. 60 to 90 GHz.
N5252-80003 ¹	Pair of N5252AW10 TxRx VNAX modules, with 1.2 m cable sets (2 sets of 3), power supplies (2), and USB drives (2), in a Pelican case. 75 to 110 GHz.
N5252-80004 ¹	Pair of N5252AW15 TxRx VNAX modules, with 1.2 m cable sets (2 sets of 3), power supplies (2), and USB drives (2), in a Pelican case. 50 to 75 GHz.
N5252-80006 ¹	Pair of N5252AW06 TxRx VNAX modules, with 1.2 m cable sets (2 sets of 3), power supplies (2), and USB drives (2), in a Pelican case. 110 to 170 GHz.
N5252-90002	N5252A User's Guide
N5252-90003	Product Note - VNAX mm-Wave Extenders for PXI Network Analyzers
9320-6695	China RoHS Addendum for Test Accessories-RF and Microwave
9320-6797	Keysight Safety Leaflet

1. The item corresponding to the band selection is included.



Figure 6. P9375A Streamline USB VNA based E-band VNA setup

Configurations with Individual purchase

M937xA PXI-VNA based configuration	2-port	4-port
	Quantity	Quantity
M9005A PXIe chassis with Option 002	1	1
M9374A or 75A PXIe VNA (M9373A can also be used for V band)	2	4
Y1212A PXI slot blockers: qty 5	1	1
Y1213A PXI EMC filter panel kit: 5 slots	1	1
Y1242A multiport cable kit	1	3
Y1281A accessory and tool kit	1	1
M9374A-551 N-port calibrated measurement	1	1
N5252AWXX-201 ¹ a pair of VDI VNAX frequency extenders	1	2
N5262ACXX ¹ calibration kit or x11644A ² waveguide calibration kit for V or W band	1	1
Desktop computer	1	1

P937xA Streamline USB VNA based configuration	2-port
	Quantity
P9374A or 75A USB-VNA (P9373A can also be used for V band)	2
Y1701A with Options 001 and 101 multiple USB instruments configuration kit	1
Y1281A accessory and tool kit	1
S97551B multiple modules measurements	1
N5252AWXX-201 ¹ a pair of VDI VNAX frequency extenders	1
N5262ACXX ¹ calibration kit or x11644A ² waveguide calibration kit for V or W band	1
Laptop PC	1

M980xA PXI-VNA based configuration	2-port (configured with one 4 or 6-port PXI VNA)	2-port (configured with two 2-port PXI VNAs)	4-port
	Quantity	Quantity	Quantity
M9010A 10-slot chassis	1	1	1
IO card for desktop pc?	1	1	1
Y1212A PXI slot blockers: qty 2	1	1	1
Y1213A PXI EMC filter panel kit: 5 slots x 2ea	1	1	1
M9804A with Option 400 or 600 (M9803A can also be used for V band) ⁴	1	N/A	Depends on VNA cards used to configure an 8-port VNA
M9804A or higher frequency model with option 200 (M9803A can also be used for V band) ⁴	N/A	2	
Y1730A-001 ³	0	1	
Y1730A-002 ³	0	0	
S95551B multiple instruments measurements	0	1	1
S95560B PXI-VNA mmWave operation with VDI frequency extenders ⁵	1	1	1
N5252AWXX-201 ¹ a pair of VDI VNAX frequency extenders	1	1	2
N5262ACXX ¹ calibration kit or x11644A ² waveguide calibration kit for V or W band	1	1	1
Desktop computer	1	1	1

1. XX: 15, 12, 10 or 06
2. x: V or W
3. -001 when M980xA option 400 is selected, -002 when M980xAs option 200 are selected.
4. Choose either of the VNA choices (of option 400/600 or option 200).
5. A discount on the S95560B is available. (N5252AWBDL) Ask your Keysight sales representative.

**P50xxA/B and P93xxB
Streamline VNA based configuration ⁶**

	2-port (configured with one 4 or 6-port Streamline VNA)	2-port (configured with two 2-port Streamline VNAs)	4-port
	Quantity	Quantity	Quantity
P5024A/B or higher frequency model with option 400, P5024A/B with Option 600 or P9384B (P5023A/B can also be used for V band) ³	1	N/A	2 (or 1)
P5004A/B or higher frequency model with Option 200 or P9374/5/7B (P5003A/B or P9373B can also be used for V band) ³	N/A	2	0 (or 1)
11904C 2.4mm (m) to 2.92mm (f) adapters ²	0 or 4	total number of 2.4 or 1.85 mm test ports on VNAs (0, 2 or 4)	total number of 2.4 or 1.85 mm test ports on VNAs (0, 2, 4 or 8)
Y1701A-002 or 003 Multiple instruments configuration kit ⁴	0	1	1
Y1701A-101 Latch kit for connecting two 1-slot instruments	0	1	0
Y1701A-202 (or -102) Latch kit for connecting 2-slot (or 1-slot) and 2-slot instruments ⁵	0	0	1
S97551B Multiple instruments measurements	0	1	1
S97560B Streamline VNA mmWave operation with VDI frequency extenders ⁸	1	1	1
N5252AWXX-201 ¹ A pair of VDI VNAX frequency extenders	1	1	2
N5262ACXX ¹ Calibration kit or x11644A ⁷ Waveguide calibration kit for V or W band	1	1	1
Laptop PC	1	1	1

1. XX: 15, 12, 10 or 06
2. Not needed for P50x5A/B, P9375B or lower frequency models.
3. Choose either of the VNA choices (of Option 400/600 or Option 200). For 4-port configuration with Streamline VNAs, you can't connect more than two VNAs, so if one of the two VNAs is with Option 600, the other one can be one 2-port VNA otherwise, both VNAs should be P502xA/B.
4. This is not needed only when one Streamline VNA is used. Y1701A-002 is needed for two P50x4A/Bs, P9374Bs or lower frequency models. Y1701A-003 for two P9375Bs, P50x5A/Bs or higher frequency models.
5. Y1701A-102 is needed only when P500xA/B with option 200 and P502xA/B with Option 400 or 600 are connected.
6. P/N M9485-23001 (Socket, 5/16 inch) is recommended as a tool kit for P50xxA/B VNAs
7. x: V or W
8. A discount on S97560B is available. (N5252AWBDL) Ask your Keysight sales representative.

PC requirements for P50xxA/B and P93xxA/B

Either of these two power sensors/meter combinations is required for power calibration.

Operating systems	Windows 7 ¹ (Windows 7 SP1 ¹ for PXI) or Windows 10 or 11 (64-bit)
Processor speed	Intel i5 6th generation or newer/Intel Xeon E3 v3 or newer
Available memory	4 GB minimum, 16 GB recommended
Available disk space	2 GB available disk space minimum
Display resolution	1024 X 768 minimum
USB	USB 3.0 port directly connected to Intel chipset

1. For Windows 7 OS, SHA-2 code signing support must be installed.
2. Refer to "[Connecting Streamline Series VNA to host PC](#)" for compatible PCs.

PC requirements for M937xA/M980xA PXIe VNA control

Either of these two power sensors/meter combinations is required for power calibration.

Operating systems	Windows 7, 10 or 11 (64-bit)
Processor speed	2.4 GHz recommended, (1.5 GHz dual core x64 minimum)
Available memory	8 GB recommended; 1 GB minimum
Available disk space	1.5 GB available hard disk space minimum
Instrument driver	Keysight IO libraries Ver. 18.1.23218.2
One open PCIe slot	For Windows 7 OS, SHA-2 code signing support must be installed

For more ordering information about the PXI-VNAs and USB/Thunderbolt Streamline VNAs, refer to the configuration guides [5991-4885EN](#), [5992-3597EN](#), [5992-2823EN](#) and [3121-1254.EN](#).

For more information about the N5252AW frequency extenders, refer to the N5252A and N5253E user's guide, [N5252A-90002](#). and Quick Start Guide, [N5252-90003](#)

Configuring a Module

Ordering a VDI VNAX-LG module, N5256AW01 and N526xAxx

1. Select model for the frequency range of the module.
2. Select option 700 or Option 701 for module with adjustable attenuator.
3. Select the cable option. The cable option selected will set power input requirement.
 - **Option 201/401/501/701/N01**
for use with 1.2 m cables, RF/LO power input requirement is 10 dBm at module input. Recommend for use with test set.
 - **Option 205/405/505/N05**
for use with 5 m cables, RF/LO power input requirement is 2 dBm at module input. Recommended for direct connect. Option N05 can also work with 1.2 m cable, which can be ordered separately as the N5262AKCBL for a Wxx or Rxx module. See options -201, -401 or -501.
 - When the N5292A test set controller is used, select option N01 and order the N5290A304 (1.2m) cable adapter for each frequency extender.
4. Select the calibration kit and the N1913PM5B calorimetric power meter with Option 701 and a taper option for the frequency range of the module. For more information about VDI VNAX-LG modules, see the product note, N5256-90002.

Ordering a VDI VNAX mini-module, N526xBxx/Cxx

1. Select model for the frequency range of the module.
2. Select Option STD or Option 001 for module with adjustable attenuator. See other options available in table.
3. Select the input power Option 120 or 500. The option selected will set the RF/LO input power requirement.
 - **Option 120**
+10 dBm required at the module input. Recommend for use with 1.2 m cable set.
 - **Option 500**
+2 dBm required at the module input. Recommended for use with 5 m cable set. The RF and LO test set power level is +10 dBm. If option 500 modules are connected using 1.2m cables, an 8 to 10 dB attenuator (0955-0319 or 0955-0317) must be placed on each RF and LO cable connected to the modules; otherwise the VNA port power driving the RF and LO must be set to the nominal +2 dBm.

4. Select the cable set option.
 - **Option 201**
Include 1.2 m cables for direct connect to 26.5 GHz PNA/PNA-X (2.92 mm connectors)
 - **Option 205**
Include 5 m cables for direct connect to 26.5 GHz PNA/PNA-X (2.92 mm connectors)
 - **Option 401**
Include 1.2 m cables for direct connect to 43.5/50/67 GHz PNA/PNA-X (2.4 mm connectors)
 - **Option 405**
Include 5 m cables for direct connect to 43.5/50/67 GHz PNA/PNA-X (2.4 mm connectors)
 - **Option 501**
Include 1.2 m cable set for connecting to N5252APXI test set adapter (or discontinued N5261A/62A test set controller) (2.92 mm connectors)
 - **Option 505**
Include 5 m cable set for connecting to N5252APXI test set adapter, N5292A test set controller, or discontinued N5261A/62A test set controller. (2.92 mm connectors.)
When the N5292A test set controller is used, select option 505 and order the N5290A304 1.2 m cable adapter and four 2.92 (or 3.5) mm female-female adapters for each frequency extender for 5 m + 1.2 m connection.
 - **Option NOC**
No cables.
When the N5292A test set controller is used, select option NOC and order the N5290A304 1.2 m cable adapter for each frequency extender for 1.2 m connection.
5. Select the calibration kit and the N1913PM5B calorimetric power meter with Option 701 and a taper option for the frequency range of the module. For more information about VDI VNAX mini-modules, see the product note, N5262-90002.

Note:

- WR10 and WR12 modules have function-restricted options SE0 and SE1 for some export restricted countries.
- A and B models can be used together. Larger VNAX-LG modules will need to be placed with feet up to match the height of the VNAX mini module.

Ordering VDI N5252AW VNAX-P modules only for use with Streamline or PXI-VNAs

1. Select model for the frequency range of the module.
2. Select Option 201. A pair of frequency extenders, power supplies, 1.2 m cable sets are included.

For more information about N5252A VNAX-P modules, see the product note, [N5252-90002](#), and the quick start guide, [N5252-90003](#).

Measurement Accessories

Accessory type	Model number	Description
Calibration kit	85059B	DC to 120 GHz 1.0 mm calibration kit
Verification kit	85059V	1.0 mm verification kit
Power sensors 5	U8489A	DC to 120 GHz 1.0 mm USB power sensor ¹
	V8486A	50 to 75 GHz waveguide power sensor
	E8486A	60 to 90 GHz waveguide power sensor
	W8486A	75 to 110 GHz waveguide power sensor
Test port cables	11500JK10 ²	110 GHz, 1.0 mm (m-f) test port cable (10 cm) ³
	11500JK13 ²	110 GHz, 1.0 mm (m-f) test port cable (13 cm) ³
	11500I	110 GHz, 1.0 mm (f-f) test port cable (8.8 cm)
	11500J	110 GHz, 1.0 mm (m-f) test port cable (16 cm)
	11500K	110 GHz, 1.0 mm (m-f) test port cable (20 cm)
	11500L	110 GHz, 1.0 mm (m-f) test port cable (24 cm)
	11500JK07	110 GHz, 1.0 mm (m-m) test port cable (30.0 cm)
Waveguide adapters	V281C	1.0 mm (f) to V-band waveguide adapter
	V281CS	1.0 mm (f) to V-band waveguide adapter, In-line ⁴
	V281D	1.0 mm (m) to V-band waveguide adapter
	V281DS	1.0 mm (m) to V-band waveguide adapter, In-line ⁴
	E281CS	1.0 mm (f) to E-band waveguide adapter, In-line ⁴
	E281DS	1.0 mm (m) to E-band waveguide adapter, In-line ⁴
	W281C	1.0 mm (f) to W-band waveguide adapter
	W281CS	1.0 mm (f) to W-band waveguide adapter, In-line ⁴
	W281D	1.0 mm (m) to W-band waveguide adapter
	W281DS	1.0 mm (m) to W-band waveguide adapter, In-line ⁴
1.0 mm coaxial adapters	Y1910A	120 GHz, 1.0 mm (m) to 1.0 mm (m) standard adapter
	Y1910B	120 GHz, 1.0 mm (f) to 1.0 mm (f) standard adapter
	Y1910C	120 GHz, 1.0 mm (m) to 1.0 mm (f) standard adapter
1.85 mm coaxial adapters	11921E	1.0 mm (m) to 1.85 mm (m) adapter
	11921F	1.0 mm (f) to 1.85 mm (f) adapter
	11921G	1.0 mm (m) to 1.85 mm (f) adapter
	11921H	1.0 mm (f) to 1.85 mm (m) adapter
2.4 mm coaxial adapters	11922A	1.0 mm (m) to 2.4 mm (m) adapter
	11922B	1.0 mm (f) to 2.4 mm (f) adapter
	11922C	1.0 mm (m) to 2.4 mm (f) adapter
	11922D	1.0 mm (f) to 2.4 mm (m) adapter
Package launch	11923A	1.0 mm (f) microcircuit connector launch assembly

1. Recommended for use with N5290/91A millimeter wave network analyzer solution.
2. The 11500JKxx cable is recommended for use with the probe positioners on FormFactor's probe station.
3. These cables will operate to 120 GHz mode free even though they are specified to work to 110 GHz.
4. Supplied by Eravant.
5. See page 24 for N1913PM5B for higher frequency bands

Key Web Resources

For information about the frequency extender modules, go to the VDI website.

Virginia Diodes, Inc. www.vadiodes.com

Confidently Covered by Keysight Services

Prevent delays caused by technical questions, or system downtimes due to instrument maintenance and repairs with Keysight Services. Keysight Services are here to support your test needs with expert technical support, instrument repair and calibration, software support, training, alternative acquisition program options, and more.

A KeysightCare agreement provides dedicated, proactive support through a single point of contact for instruments, software, and solutions. KeysightCare covers an extensive group of instruments, application software, and solutions and ensures optimal uptime, faster response, faster access to experts, and faster resolution.

Keysight Services

Offering	Benefits
KeysightCare 	KeysightCare provides elevated support for Keysight instruments and software, with access to technical support experts that respond within a specified time and ensure committed repair and calibration turnaround times (TAT). KeysightCare offers multiple service agreement tiers, including KeysightCare Assured, Enhanced, and Application Software Support. See the KeysightCare data sheet for details.
KeysightCare Assured	KeysightCare Assured goes beyond basic warranty with repair services that include committed TAT and unlimited access to technical experts.
KeysightCare Enhanced	KeysightCare Enhanced includes all the benefits of KeysightCare Assured plus Keysight's accurate and reliable calibration services, accelerated, and committed TAT, and technical response.
Keysight Support Portal & Knowledge Center	All KeysightCare tiers include access to the Keysight Support Portal where you can manage support and service resources related to your assets such as service requests, and status, or browse the Knowledge Center.
Education Services	Build confidence and gain new skills to make accurate measurements, with flexible Education Services developed by Keysight experts. Including Start-up Assistance.
Alternative product acquisition	
KeysightAccess	Reduce budget challenges with a subscription service enabling you to get the instruments, software, and technical support you want for your test needs.

Recommended Services

Maximize your test system up-time by securing technical support, repair, and calibration services with committed response and turnaround times. 1-year KeysightCare Assured is included in every new instrument purchase. Obtain multi-year KeysightCare upfront to eliminate the need for lengthy and tedious paperwork and yearly requests for maintenance budget. Plus, you benefit from secured service for 2, 3, or 5 years.

Service	Function
KeysightCare Enhanced*	Includes Tech Support, Warranty and Calibration
R-55B-001-1	KeysightCare Enhanced – Upgrade 1 year
R-55B-001-2	KeysightCare Enhanced – Extend to 2 years
R-55B-001-3	KeysightCare Enhanced – Extend to 3 years (Recommended)
R-55B-001-5	KeysightCare Enhanced – Extend to 5 years (Recommended)
KeysightCare Assured	Includes Tech Support and Warranty
R-55A-001-2	KeysightCare Assured – Extend to 2 years
R-55A-001-3	KeysightCare Assured – Extend to 3 years
R-55A-001-5	KeysightCare Assured – Extend to 5 years
Start-Up Assistance	
PS-S10	Included – instrument fundamentals and operations starter
PS-S20	Optional, technology & measurement science standard learning

* Available in select countries. For details, please view the [datasheet](#). R-55B-001-2/3/5 must be ordered with R-55B-001-1.