

# **Agilent M9185A PXI D/A Converter**

## **Service Guide**



**Agilent Technologies**

# Notices

© Agilent Technologies, Inc. 2010-2011

No part of this manual may be reproduced in any form or by any means (including electronic storage and retrieval or translation into a foreign language) without prior agreement and written consent from Agilent Technologies, Inc. as governed by United States and international copyright laws.

## Manual Part Number

M9185-90010

## Edition

Fourth Edition, May 23, 2011

Agilent Technologies, Inc.  
5301 Stevens Creek Blvd.  
Santa Clara, CA 95051 USA

## Sales and Technical Support

To contact Agilent for sales and technical support, refer to the "support" links on the following Agilent web resources:

- [www.agilent.com/find/M9185A](http://www.agilent.com/find/M9185A)  
(product-specific information and support, software and documentation updates)
- [www.agilent.com/find/assist](http://www.agilent.com/find/assist)  
(worldwide contact information for repair and service)

Information on preventing damage to your Agilent equipment can be found at [www.agilent.com/find/tips](http://www.agilent.com/find/tips).

## Warranty

**The material contained in this document is provided "as is," and is subject to change, without notice, in future editions. Further, to the maximum extent permitted by the applicable law, Agilent disclaims all warranties, either express or implied, with regard to this manual and any information contained herein, including but not limited to the implied warranties of merchantability and fitness for a particular purpose. Agilent shall not be liable for errors or for incidental or consequential damages in connection with the furnishing, use, or performance of this document or of any information contained herein. Should Agilent and the user have a separate written agreement with warranty terms covering the material in this document that conflict with these terms, the warranty terms in the separate agreement shall control.**

## Technology Licenses

The hardware and/or software described in this document are furnished under a license and may be used or copied only in accordance with the terms of such license.

## Restricted Rights Legend

U.S. Government Restricted Rights. Software and technical data rights granted to the federal government include only those rights customarily provided to end user customers. Agilent provides this customary commercial license in Software and technical data pursuant to FAR 12.211 (Technical Data) and 12.212 (Computer Software) and, for the Department of Defense, DFARS 252.227-7015 (Technical Data - Commercial Items) and DFARS 227.7202-3 (Rights in Commercial Computer Software or Computer Software Documentation).

## Safety Notices

### CAUTION

A **CAUTION** notice denotes a hazard. It calls attention to an operating procedure, practice, or the likes of that, if not correctly performed or adhered to, could result in damage to the product or loss of important data. Do not proceed beyond a **CAUTION** notice until the indicated conditions are fully understood and met.

---

### WARNING

A **WARNING** notice denotes a hazard. It calls attention to an operating procedure, practice, or the likes of that, if not correctly performed or adhered to, could result in personal injury or death. Do not proceed beyond a **WARNING** notice until the indicated conditions are fully understood and met.

---

## WARNING

**If this product is not used as specified, the protection provided by the equipment could be impaired. This product must be used in a normal condition (in which all means for protection are intact) only.**

---

The types of product users are:

- Responsible body is the individual or group responsible for the use and maintenance of equipment, for ensuring that the equipment is operated within its specifications and operating limits, and for ensuring that operators are adequately trained.
- Operators use the product for its intended function. They must be trained in electrical safety procedures and proper use of the instrument. They must be protected from electric shock and contact with hazardous live circuits.
- Maintenance personnel perform routine procedures on the product to keep it operating properly (for example, setting the line voltage or replacing consumable materials). Maintenance procedures are described in the user documentation. The procedures explicitly state if the operator may perform them. Otherwise, they should be performed only by service personnel.
- Service personnel are trained to work on live circuits, perform safe installations, and repair products. Only properly trained service personnel may perform installation and service procedures.

Exercise extreme caution when a shock hazard is present. Lethal voltage may be present on cable connector jacks or test fixtures. The American National Standards Institute (ANSI) states that a shock hazard exists when voltage levels greater than 30V RMS, 42.4V peak, or 60VDC are present.

A good safety practice is to expect that hazardous voltage is present in any unknown circuit before measuring.

Operators of this product must be protected from electric shock at all times. The responsible body must ensure that operators are prevented access and/or insulated from every connection point. In some cases, connections must be exposed to potential human contact. Product operators in these circumstances must be trained to protect themselves from the risk of electric shock.

Before operating an instrument, ensure that the line cord is connected to a properly-grounded power receptacle. Inspect the connecting cables, test leads, and jumpers for possible wear, cracks, or breaks before each use.

When installing equipment where access to the main power cord is restricted, such as rack mounting, a separate main input power disconnect device must be provided in closed proximity to the equipment and within easy reach of the operator.

For maximum safety, do not touch the product, test cables, or any other instruments while power is applied to the circuit under test. ALWAYS remove power from the entire test system and discharge any capacitors before: connecting or disconnecting cables or jumpers, installing or removing switching cards, or making internal changes, such as installing or removing jumpers.

Do not touch any object that could provide a current path to the common side of the circuit under test or power line (earth) ground. Always make measurements with dry hands while standing on a dry, insulated surface capable of withstanding the voltage being measured.

The instrument and accessories must be used in accordance with its specifications and operating instructions, or the safety of the equipment may be impaired.

## CAUTION

- Do not exceed the maximum signal levels of the instruments and accessories, as defined in the specifications and operating information, and as shown on the instrument or test fixture panels, or switching card.
  - Chassis connections must only be used as shield connections for measuring circuits, NOT as safety earth ground connections.
  - If you are using a test fixture, keep the lid closed while power is applied to the device under test. Safe operation requires the use of a lid interlock.
  - Instrumentation and accessories shall not be connected to humans.
- 

To maintain protection from electric shock and fire, replacement components in mains circuits - including the power transformer, test leads, and input jacks - must be purchased from Agilent. Standard fuses with applicable national safety approvals may be used if the rating and type are the same. Other components that are not safety-related may be purchased from other suppliers as long as they are equivalent to the original component (note that selected parts should be purchased only through Agilent to maintain accuracy and functionality of the product). If you are unsure about the applicability of a replacement component, call an Agilent office for information.

## WARNING

**No operator serviceable parts inside. Refer servicing to qualified personnel. To prevent electrical shock do not remove covers.**

---

## Front and Rear Panels Symbols



The CE mark is a registered trademark of the European Community.



N10149

The C-Tick mark is a registered trademark of the Australian Spectrum Management Agency.



This symbol indicates product compliance with the Canadian Interference-Causing Equipment Standard (ICES-001). It also identifies the product is an Industrial Scientific and Medical Group 1 Class A product (CISPR 11, Clause 4).



This symbol indicates separate collection for electrical and electronic equipment, mandated under EU law as of August 13, 2005. All electric and electronic equipment are required to be separated from normal waste for disposal (Reference WEEE Directive, 2002/96/EC).



This symbol indicates the time period during which no hazardous or toxic substance elements are expected to leak or deteriorate during normal use. Forty years is the expected useful life of the product.

## Cleaning Precautions

### WARNING

**To prevent electrical shock, disconnect the Agilent Technologies instrument from mains before cleaning. Use a dry cloth or one slightly dampened with water to clean the external case parts. Do not attempt to clean internally. To clean the connectors, use alcohol in a well-ventilated area. Allow all residual alcohol moisture to evaporate, and the fumes to dissipate prior to energizing the instrument.**

---

# Table of Contents

## 1 General Information and Specifications

General Information	2
General Specifications	3
Performance Specifications	4
DAC specifications	4
DC Voltage	4
DC Current	5
I/O Trigger Characteristics	5
Declaration of Conformity (DoC)	6

## 2 Module Installation

Unpack and Inspect the Module	8
ESD precaution	8
Inspect the module for damage	9
Return the module for service	10
Verify the Shipment Contents	11
Install the Software	12
System requirements	12
Power up the controller	13
Install the softwares	13
Install the Module	15
M9185A front panel for 8-channel and 16-channel	19
M9185A system connections	25

## 3 Performance Verifications and Adjustments

Performance Verification	28
Module Calibration Procedure	31
Voltage calibration	31

Current calibration 32

## **4 Replaceable Parts**

To Order Replaceable Parts 36

## **5 Service**

Troubleshooting Techniques 44

Identifying the problem 44

Repair/Maintenance Guidelines 45

ESD precautions 45

Post-repair safety checks 46

Agilent Technologies Calibration Services 47

Calibration interval 47

Types of Service Available 47

Extended Service Contracts 48

Obtaining Repair Service (Worldwide) 48

Re-packaging for Shipment 49

Cleaning 49

## List of Figures

Figure 2-1	Static-safe work station example	8
Figure 2-2	InstallShield Wizard for Agilent M9185A	14
Figure 2-3	Installing the module to the chassis	16
Figure 2-4	Module installation procedures	18
Figure 2-5	M9185A 8-channel DAC front panel	19
Figure 2-6	M9185A 16-channel DAC front panel	20
Figure 2-7	M9185A output connector pinout	21
Figure 2-8	M9185A module functional block diagram	25
Figure 3-9	SFP interface	28
Figure 3-10	Set an output range	29
Figure 3-11	Set the trigger type	29
Figure 3-12	Select the single channel and output	30
Figure 3-13	Green LED at Channel 1	30
Figure 4-14	M9185A 8-channel module replaceable parts	37
Figure 4-15	M9185A 16-channel module replaceable parts	38





## List of Tables

Table 1-1	M9185A module general specifications	3
Table 2-2	M9185A output pin assignment (CHAN 1 – 8)	22
Table 2-3	M9185A output pin assignment (CHAN 9 – 16)	23
Table 3-4	Voltage calibration settings and limits	31
Table 3-5	Current calibration settings and limits	32
Table 3-6	M9185A functional tests list	33
Table 4-7	M9185A 8-channel module replaceable parts list	39
Table 4-8	M9185A 16-channel module replaceable parts list	40





# 1 General Information and Specifications

General Information	2
General Specifications	3
Performance Specifications	4
Performance Specifications	4
DAC specifications	4

This chapter specifies the characteristics, environmental conditions, and specifications of the M9185A.



# General Information

The M9185A is a 2- or 3-slot, PXI-based D/A Converter (DAC) with 16-bit resolution that is capable of providing DC voltages as stimulus to the Device-Under-Test (DUT). The M9185A comes in 8 or 16 fully independent and isolated channel option, where the 8-channel option is a 2-slot size module, and the 16-channel option is a 3-slot size module. Each channel in the M9185A DAC is capable of supplying voltages between  $-16\text{ V DC}$  and  $+16\text{ V DC}$  at  $500\text{ }\mu\text{V}$  resolution. Each channel can also generate current between  $-20\text{ mA}$  and  $+20\text{ mA}$  at  $630\text{ nA}$  resolution.

The M9185A DAC also comes with a built-in hardware remote SENSE feature, which is able to detect the output voltage levels and feedback the information to the DAC circuitry to compensate for the voltage drop at the receiving end of a DUT. This feature is ideal to ensure the accuracy of the stimulus signals being presented to the DUT for better test performance.

When using the remote sensing feature, connect sense wires from the load to the High Sense and Low Sense terminals for the desired channels. When outputting current, the High Sense and Low Sense terminals are not used and are opened. For protection, each channel incorporates a fuse that will open at greater than  $20\text{ mA}$ . If an overload condition exists, the fuse will open, but no error will be generated. To reset the fuse, remove the overload and wait for a few minutes for the fuse to cool.

## General Specifications

**Table 1-1** M9185A module general specifications

Description	Specification
Temperature range	<ul style="list-style-type: none"> <li>• Operating</li> <li>• Storage</li> </ul>
	<ul style="list-style-type: none"> <li>• 0 °C to 55 °C</li> <li>• –40 °C to + 70 °C</li> </ul>
Relative humidity	80%, 0 ° to 55 °C (Non condensing)
Altitude	<ul style="list-style-type: none"> <li>• 10,000 ft. (Operating)</li> <li>• 15,000 ft. (Non-operating)</li> </ul>
Certifications and compliance	<ul style="list-style-type: none"> <li>• CE mark compliance</li> <li>• Safety</li> <li>• EMC</li> <li>• Pollution degree 2</li> </ul>
	<ul style="list-style-type: none"> <li>• 2006/95/EC; 2004/108/EC</li> <li>• EN/ IEC 61010-1</li> <li>• EN/IEC 61326-1</li> </ul>
Warm-up time	30 minutes
PXI power requirements (typical)	<ul style="list-style-type: none"> <li>• 15 W (8-Channel)</li> <li>• 25 W (16-Channel)</li> </ul>
Recommended calibration interval	1 year
Physical characteristics	<ul style="list-style-type: none"> <li>• Dimensions</li> <li>• Weight</li> <li>• Front Panel Connector</li> </ul>
	<ul style="list-style-type: none"> <li>• 8-Ch: 2-slot, PXI/cPCI module; 40.30 × 128.40 × 215.00 mm (1.59 × 5.06 × 8.46 in.)</li> <li>• 16-Ch:3-slot, PXI/cPCI module; 60.50 × 128.40 × 215.00 mm (2.38 × 5.06 × 8.46 in.)</li> <li>• 8-Ch: 0.47 kg (1.04 lbs.)</li> <li>• 16-Ch: 0.60 kg (1.32 lbs.)</li> <li>• Stacked VHDCI Receptacle</li> </ul>

## Performance Specifications

### DAC specifications

<b>Number of Channels</b>	:	8 or 16 channels
<b>Resolution</b>	:	16-bit
<b>Isolation</b>	:	> 80 Vdc/ac peak (channel-to-chassis or channel to channel)
<b>Synchronization</b>	:	Software commands or external trigger
<b>Settling Time</b>	:	500 $\mu$ s (typical)

### DC Voltage

<b>Range</b>	:	$\pm 16$ V up to 10 mA
<b>Resolution</b>	:	16-bit = 500 $\mu$ V
<b>Accuracy</b>	:	$\pm (0.05\% + 3.0$ mV)
<b>Ripple and Noise</b>	:	< 80 mVpk-pk (typical)

## DC Current

<b>Range</b>	: $\pm 20$ mA
<b>Resolution</b>	: 16-bit = 630 nA
<b>Accuracy</b>	: $\pm (0.09\% + 5.0 \mu\text{A})$
<b>Ripple and Noise</b>	: $< 2 \mu\text{Arms}$ (typical)

## I/O Trigger Characteristics

### Trigger Input

<b>Input Level</b>	: TTL compatible (3.3 V logic, 5 V tolerant)
<b>Slope</b>	: Rising or falling (selectable)
<b>Pulse Width</b>	: $> 100$ nS
<b>Input Impedance</b>	: $> 10$ k $\Omega$ typical, DC coupled

### Trigger Output

<b>Level</b>	: TTL compatible into 1 k $\Omega$ (3.3 V logic)
<b>Output Impedance</b>	: 50 $\Omega$ typical

## 1 General Information and Specifications

Performance Specifications

### Declaration of Conformity (DoC)

The Declaration of Conformity (DoC) for this product is available on the Agilent Technologies website. You can search for the DoC by its product model or description at the following web address:

<http://regulations.corporate.agilent.com/DoC/search.htm>

#### NOTE

If you are unable to locate the DoC, please contact your local Agilent representative

---





## 2 Module Installation

Unpack and Inspect the Module	8
ESD precaution	8
Inspect the module for damage	9
Return the module for service	10
Verify the Shipment Contents	11
Install the Software	12
System requirements	12
Power up the controller	13
Install the softwares	13
Install the Module	15
M9185A front panel for 8-channel and 16-channel	19
M9185A system connections	25

This chapter specifies the installation procedures of the M9185A PXI D/A converter module.

## 2 Module Installation

### Unpack and Inspect the Module

# Unpack and Inspect the Module

#### CAUTION

The M9185A is shipped in materials which prevent damage from static. The module should only be removed from the packaging in an anti-static area after ensuring that correct anti-static precautions are taken. Store all modules in anti-static envelopes when not in use.

## ESD precaution

Electrostatic discharge (ESD) can damage or destroy electronic components. All work on electronic assemblies should be performed at a static-safe work station. The following figure shows an example of a static-safe work station using two types of ESD protection.

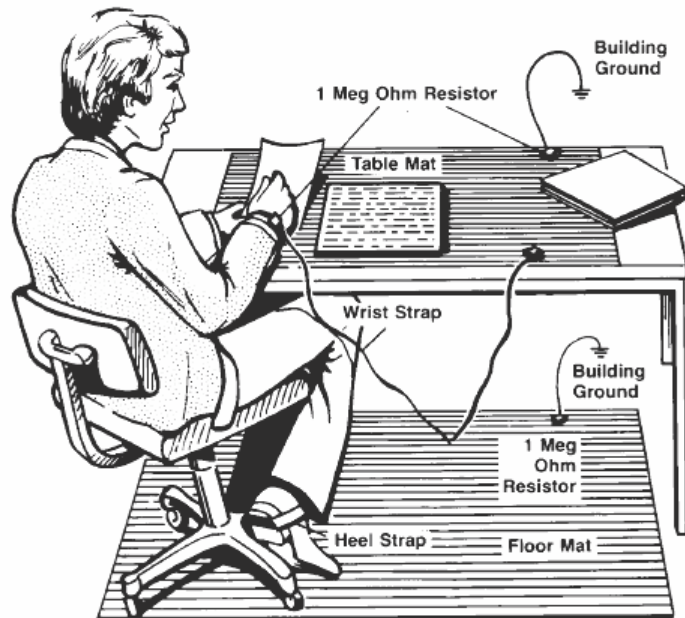

Figure 2-1 Static-safe work station example

Purchase acceptable ESD accessories from your local supplier.

- Conductive table-mat and wrist-strap combination.
- Conductive floor-mat and heel-strap combination.

Both types, when used together, provide a significant level of ESD protection. Of the two, only the table-mat and wrist-strap combination provides adequate ESD protection when used alone. To ensure user safety, the static-safe accessories must provide at least  $1 \Omega$  of isolation from ground.

**WARNING**

**These techniques for a static-safe work station should not be used when working on circuitry with a voltage potential greater than 500 V.**

---

## Inspect the module for damage

After unpacking the M9185A, carefully inspect the unit for any shipping damage. Report any damage to the shipping agent immediately, as such damage is not covered by the warranty (warranty information can be found at the beginning of this manual).

**CAUTION**

To avoid damage when handling a module, do not touch exposed connector pins.

---

**NOTE**

Information on preventing damage to your Agilent equipment can be found at [www.agilent.com/find/tips](http://www.agilent.com/find/tips).

---

### Return the module for service

Should it become necessary to return the M9185A for repair or service, follow the steps below:

- 1 Review the warranty information shipped with your product.
- 2 Contact Agilent to obtain a Return Material Authorization (RMA) and return address. If you need assistance finding Agilent's contact information, go to [www.agilent.com/find/assist](http://www.agilent.com/find/assist) (worldwide contact information for repair and service) or refer to the Support information on the product web page at [www.agilent.com/find/M9185A](http://www.agilent.com/find/M9185A).
- 3 Write the following information on a tag and attach it to the malfunctioning equipment.
  - Name and address of owner. A P.O. box is not acceptable as a return address.
  - Product model number (for example, M9185A).
  - Product serial number (for example, MYXXXXXXXXX). The serial number label is located on the side panel of the module. The serial number can also be read from the Soft Front Panel interface, but only after the software is installed.
  - Description of failure or service required.
- 4 Carefully pack the module in its original ESD bag and packing carton. If the original carton is not available, use bubble wrap or packing peanuts and place the instrument in a sealed container and mark the container "FRAGILE".
- 5 On the shipping label, write "**ATTENTION REPAIR DEPARTMENT**" and the RMA number.

#### NOTE

If any correspondence is required, refer to the product by its serial number and model number.

## Verify the Shipment Contents

The following items are included in the M9185A shipment:

- *M9185A Software and Product Information CD-ROM* (M9185-10001) - contains software, drivers, and all product documentation in PDF format.
- Printed copy of this document, *M9185A Startup Guide*
- Calibration certificate

### NOTE

Every PXI module is shipped with a Software and Product Information CD-ROM. The M9185A-CD1 option provides the *M9185A Software and Product Information CD-ROM* (M9185-10001).

All of the files contained on the CD are available for free download at the Agilent Web site at [www.agilent.com/find/M9185A](http://www.agilent.com/find/M9185A).

---

# Install the Software

## System requirements

Hardware/Software	Minimum requirements
Operating system	<ul style="list-style-type: none"><li>• Windows XP (32-bit),</li><li>• Windows Vista (32-bit),</li><li>• Windows Vista (64-bit),</li><li>• Windows 7 (32-bit), or</li><li>• Windows 7 (64-bit)</li></ul>
Chassis	A cPCI, PXI-1, or PXIh chassis peripheral slot. The Agilent M9018A chassis is recommended.
Interface controller	A PXI or PXIe remote or embedded controller.
Remote controller	An Agilent M9045A ExpressCard interface (for portable laptops) or Agilent M9047A PCIe interface (for desktop PCs) or equivalent PXI or PXIe remote controllers running one of the above operating systems.
Embedded controller	An Agilent M9021A System Interface Card, or equivalent embedded controller running one of the above operating systems. <b>Note:</b> The embedded controller must be compatible with the Agilent M9018A chassis.
RAM	512 MB RAM to run LabVIEW, IO Library Suite, and soft front panels.
Screen resolution	A screen resolution of at least 1024 × 768 pixels is recommended.
Agilent IO Libraries Suite	Agilent IO Libraries Suite 16.0 and above is required.
Adobe® Reader®	Adobe® Reader® version 6.0 or higher is required to view the provided PDF files.

## Power up the controller

If you are using a remote controller, power up the host computer.

If you are using an embedded controller, complete the following steps:

- 1 Install the embedded controller module into a compatible chassis.

Recommended: Agilent M9018A 18 slot PXIe Chassis

- 2 Connect your I/O peripherals (mouse, keyboard, and monitor).
- 3 Power up the chassis.

## Install the softwares

The M9185A softwares are located on the bundled CD (M9185-10001). The same softwares are also available for free download at the Agilent Web site: [www.agilent.com/find/M9185A](http://www.agilent.com/find/M9185A).

This installation includes the following:

- Agilent IO Library Suite (IOLS), which includes the Agilent Connection Expert.
- Soft Front Panel (SFP), device drivers (IVI-C and IVI-COM, and LabVIEW G), and related user documentation for the M9185A.

### NOTE

Each PXI module has its own device driver (IVI-C and IVI-COM, and LabVIEW G) and soft front panel (SFP) software.

- 1 From the CD browser, launch the installer.
- 2 Follow the installer prompts to install all software and documentation for the M9185A PXI D/A Converter Module.

## 2 Module Installation

Install the Software



**Figure 2-2** InstallShield Wizard for Agilent M9185A

- 3 After installation is complete, power down the chassis (and the host PC if using the remote controller).



## Install the Module

### CAUTION

- The PXI hardware does not support “hot-swapping” capabilities (changing modules while power is applied to the chassis).
- Before installing the M9185A into the chassis, ensure that the chassis is powered off and unplugged to prevent damage to the module.

### NOTE

The M9185A module can be used in a chassis with a cPCI, PXI-1, or PXIh chassis peripheral slot.



The module can be installed in any standard PXI slot marked with a peripheral slot compatibility image (a circle containing the slot number).



The module can also be installed in any hybrid PXI slot marked with a peripheral slot compatibility image (the letter “H” and a solid circle containing the slot number).

- 1 Ensure that the chassis power switch is at the Off (Standby) position before you unplug the PXI chassis.
- 2 If the chassis has multiple fan speed settings, ensure that the fans are set to automatic. Do not set the fan speed to low or turn it off.
- 3 Position the chassis so that there is ample space between the chassis fan intake and exhaust vents. Blockage by walls or obstructions affects the air flow needed for cooling. (Refer to the chassis documentation for more information about cooling).
- 4 If you are using an embedded controller, proceed to [step 5](#). If you are using a remote controller, skip to [step 6](#).

## 2 Module Installation

### Install the Module

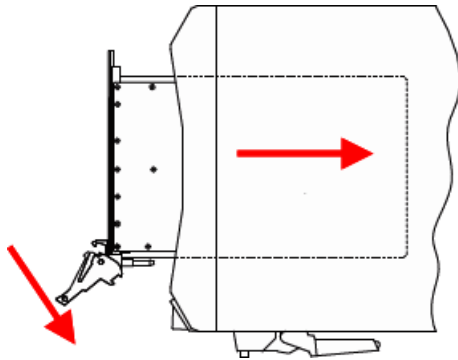

**Figure 2-3** Installing the module to the chassis

- 5** Hold the module by the injector/ejector handle, and slide it into an available PXI (or hybrid) slot, as shown in [Figure 2-3](#).
  - Install the module into the PXI slot of the chassis by placing the module card edges into the front module guides (top and bottom).
  - Slide the module to the rear of the chassis and assure that the injector/ejector handle is pushed down in the unlatched (downward) position.
  - Slide the module completely into the chassis.
  - When you begin to feel resistance, push up on the injector/ejector handle to fully inject the module into the chassis.
- 6** If you are using a remote controller, install the System Interface Card in the chassis.
- 7** Latch the module by pulling up on the injector/ejector handle and secure the front panel to the chassis using the module front-panel mounting screws.
- 8** Tighten the screws on the module (or remote controller) front panel. Performance may suffer if the screws are not tightened properly.
- 9** Verify that the PXI chassis fans are operable and free of dust and other contaminants that may restrict airflow.

- 10** Install all chassis covers and filler panels after installing the module. Missing filler panels may disrupt necessary air circulation in the chassis.
- 11** If you are using a remote controller, connect the System Interface Card in the chassis to host computer.
- 12** Plug in and power up the PXI chassis.
- 13** If you are using a remote controller, reboot the host PC.

**WARNING**

**Tighten the screws on the module front panel. Protection provided by the equipment could be impaired if the screws are not tightened properly.**

---

## 2 Module Installation

Install the Module

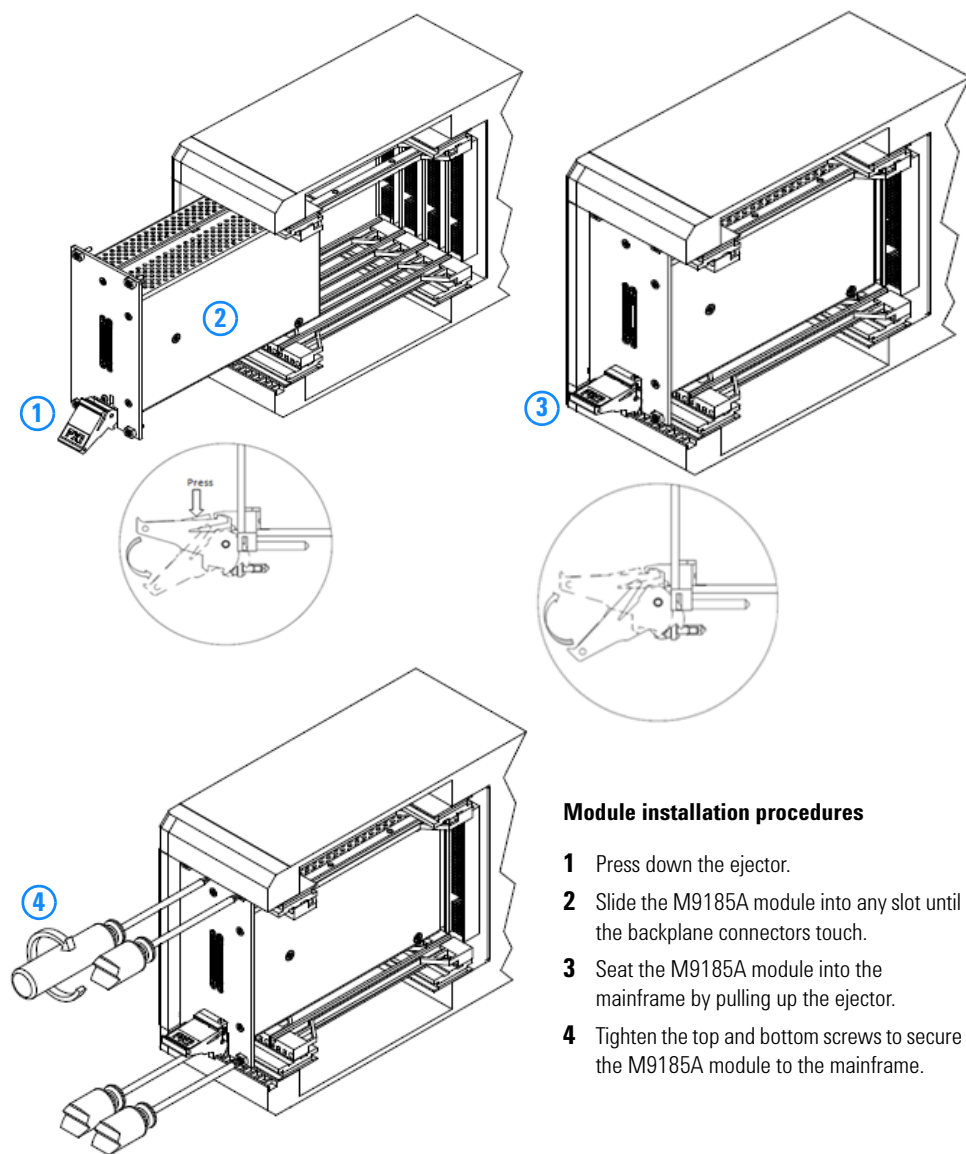

### Module installation procedures

- 1 Press down the ejector.
- 2 Slide the M9185A module into any slot until the backplane connectors touch.
- 3 Seat the M9185A module into the mainframe by pulling up the ejector.
- 4 Tighten the top and bottom screws to secure the M9185A module to the mainframe.

Figure 2-4 Module installation procedures

## M9185A front panel for 8-channel and 16-channel

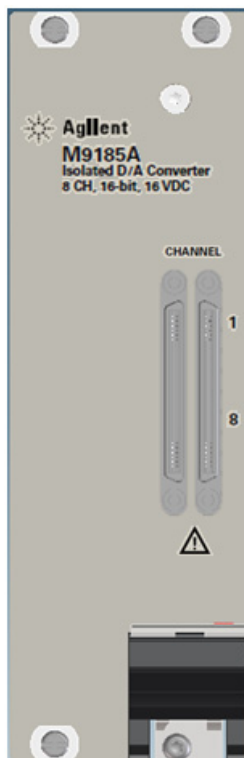
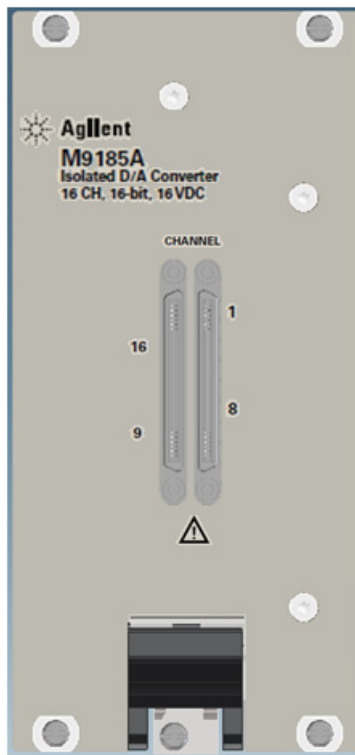

Figure 2-5 M9185A 8-channel DAC front panel

## 2 Module Installation

Install the Module



**Figure 2-6** M9185A 16-channel DAC front panel

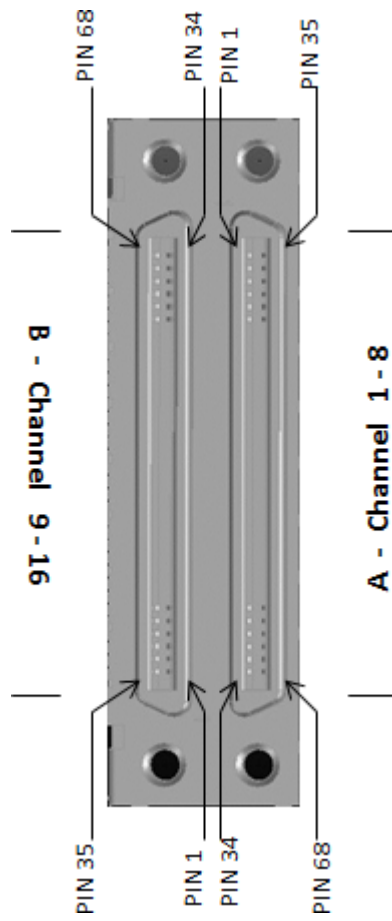

Figure 2-7 M9185A output connector pinout

## 2 Module Installation

Install the Module

**Table 2-2** M9185A output pin assignment (CHAN 1 – 8)

1	CH1_LO	35	CH1_HI
2	CH1_LOS	36	CH1_HIS
3	GND	37	GND
4	CH2_LO	38	CH2_HI
5	CH2_LOS	39	CH2_HIS
6	GND	40	GND
7	CH3_LO	41	CH3_HI
8	CH3_LOS	42	CH3_HIS
9	GND	43	GND
10	CH4_LO	44	CH4_HI
11	CH4_LOS	45	CH4_HIS
12	GND	46	GND
13	CH5_LO	47	CH5_HI
14	CH5_LOS	48	CH5_HIS
15	GND	49	GND
16	CH6_LO	50	CH6_HI
17	CH6_LOS	51	CH6_HIS
18	GND	52	GND
19	CH7_LO	53	CH7_HI
20	CH7_LOS	54	CH7_HIS
21	GND	55	GND
22	CH8_LO	56	CH8_HI
23	CH8_LOS	57	CH8_HIS
24	GND	58	GND
25	GND	59	GND



**Table 2-2** M9185A output pin assignment (CHAN 1 – 8) (continued)

26	CAL_GND	60	CAL_GND
27	CAL_GND	61	CAL_GND
28	DMM_H	62	DMM_L
29	DMM_C	63	CAL_GND
30	CAL_GND	64	CAL_GND
31	CAL_GND	65	CAL_GND
32	GND	66	GND
33	EXT_TRIG_IO	67	GND
34	GND	68	GND

**Table 2-3** M9185A output pin assignment (CHAN 9 – 16)

1	CH9_LO	35	CH9_HI
2	CH9_LOS	36	CH9_HIS
3	GND	37	GND
4	CH10_LO	38	CH10_HI
5	CH10_LOS	39	CH10_HIS
6	GND	40	GND
7	CH11_LO	41	CH11_HI
8	CH11_LOS	42	CH11_HIS
9	GND	43	GND
10	CH12_LO	44	CH12_HI
11	CH12_LOS	45	CH12_HIS
12	GND	46	GND
13	CH13_LO	47	CH13_HI
14	CH13_LOS	48	CH13_HIS

## 2 Module Installation

### Install the Module

**Table 2-3** M9185A output pin assignment (CHAN 9 – 16) (continued)

15	GND	49	GND
16	CH14_LO	50	CH14_HI
17	CH14_LOS	51	CH14_HIS
18	GND	52	GND
19	CH15_LO	53	CH15_HI
20	CH15_LOS	54	CH15_HIS
21	GND	55	GND
22	CH16_LO	56	CH16_HI
23	CH16_LOS	57	CH16_HIS
24	GND	58	GND
25	GND	59	GND
26	GND	60	GND
27	GND	61	GND
28	GND	62	GND
29	GND	63	GND
30	GND	64	GND
31	GND	65	GND
32	GND	66	GND
33	GND	67	GND
34	GND	68	GND

## M9185A system connections

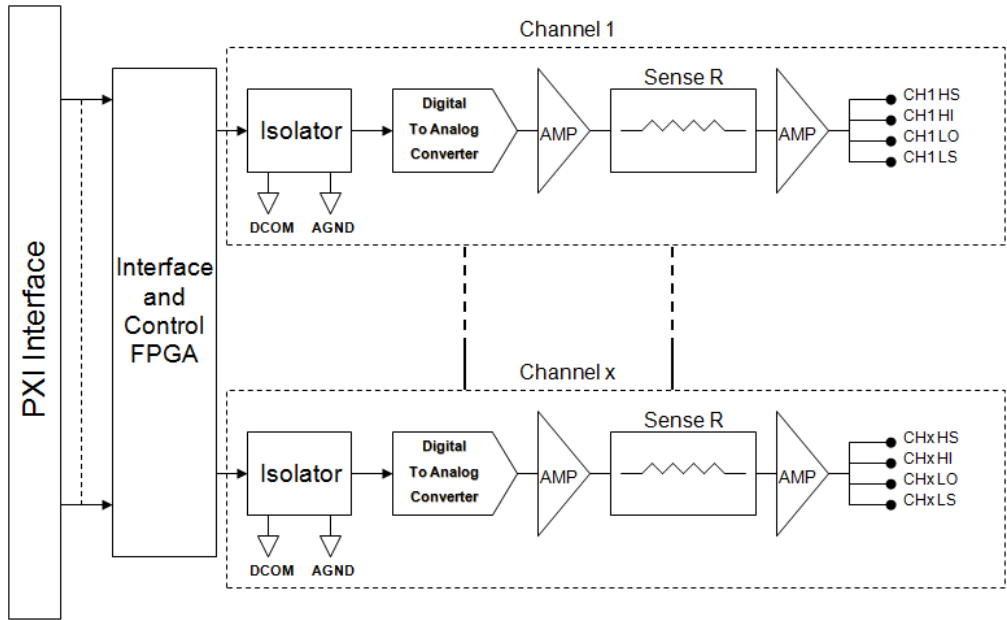

Figure 2-8 M9185A module functional block diagram

## **2** **Module Installation**

Install the Module

THIS PAGE IS INTENTIONALLY LEFT BLANK.



## **3** **Performance Verifications and Adjustments**

Performance Verification	28
Module Calibration Procedure	31
Voltage calibration	31
Current calibration	32

This chapter contains procedures for verification of the module's performance and adjustment (calibration).



### 3 Performance Verifications and Adjustments

#### Performance Verification

## Performance Verification

The intention of this step is to verify the basic operations of the newly installed module.

Run the Agilent Connection Expert (ACE) by clicking its desktop shortcut icon, or by clicking **Start > All Programs > Agilent IO Library Suite > Agilent Connection Expert**.

The ACE will display all modules that are connected and installed. Review the configuration data and launch the M9185A Soft Front Panel (SFP). The M9185A SFP will provide control over the module for operational verification procedures.

This is a screen capture of the SFP interface:

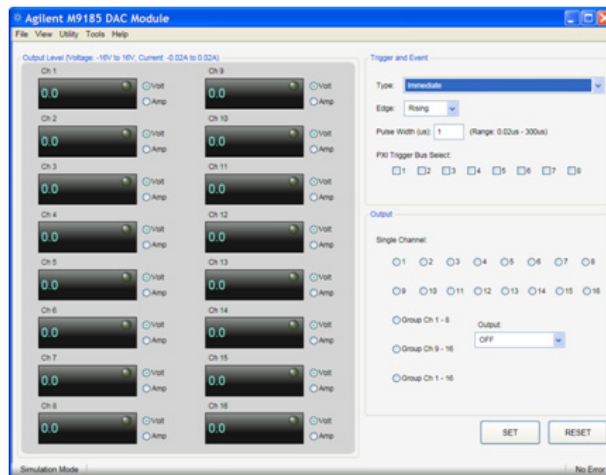

**Figure 3-9** SFP interface

To start, set an output level for a channel. In this example, set Channel 1 to 16 volts.

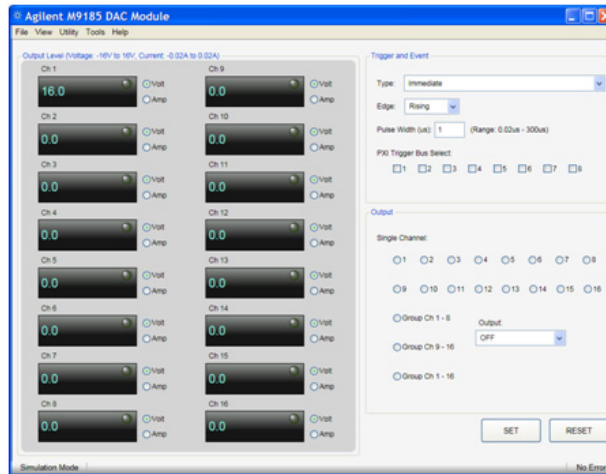

**Figure 3-10** Set an output range

Next, set the trigger type as Immediate.

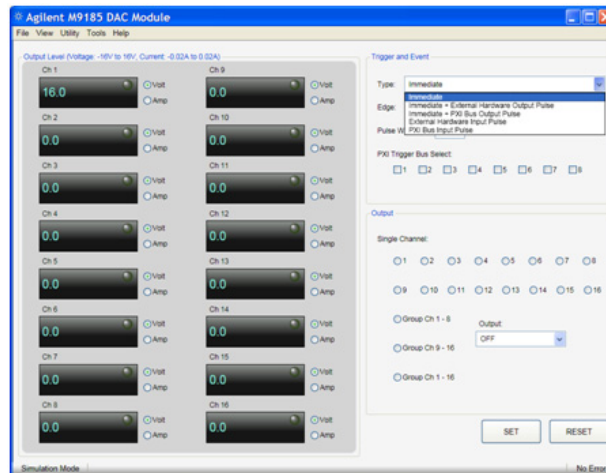
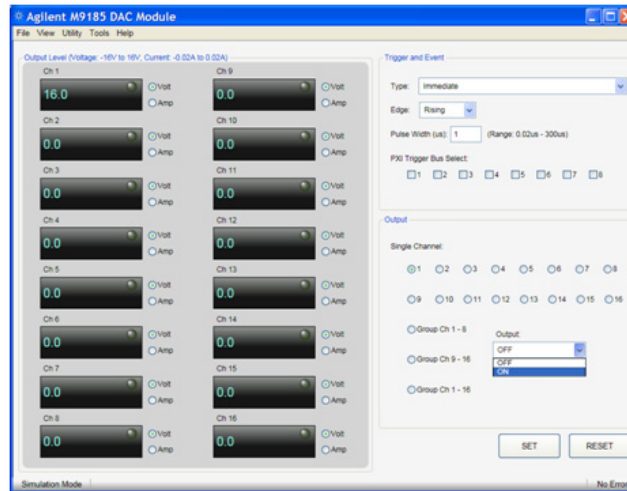

**Figure 3-11** Set the trigger type

### 3 Performance Verifications and Adjustments

#### Performance Verification

Set the single channel to 1 and set the output as ON.



**Figure 3-12** Select the single channel and output

Click **SET** and a green LED will appear at Channel 1.

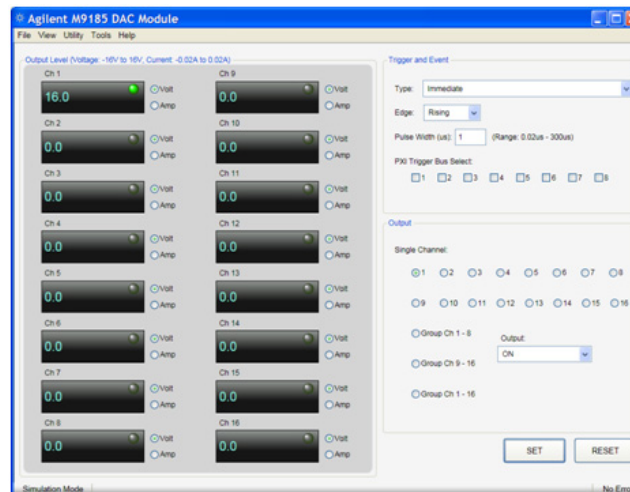

**Figure 3-13** Green LED at Channel 1



You may refer to Agilent *M9185A Soft Front Panel Help* for details on how to use the SFP.

## Module Calibration Procedure

### CAUTION

Overwriting of calibration values into the product internal EEPROM should be done by an authorized service personnel only.

### Voltage calibration

- 1 Connect the CHx HI and CHx LO of the M9185A module to the HI and LO terminal of a Voltmeter respectively; 'x' denotes the channel number.
- 2 Set the voltage values and adjust the internal DAC value until the reading on the voltmeter falls within the tolerances as shown in [Table 3-4](#). Adjustments should be made according to the top to bottom order of [Table 3-4](#).

**Table 3-4** Voltage calibration settings and limits

Voltage settings	Tolerances
0 V	±1 mV
+4 V	±1 mV
+8 V	±1 mV
+12 V	±2 mV
+16 V	±2 mV
-4 V	±1 mV
-8 V	±1 mV
-12 V	±2 mV
-16 V	±2 mV

### 3 Performance Verifications and Adjustments

#### Module Calibration Procedure

- 3 Repeat the adjustment for each channel of the M9185A module.

## Current calibration

- 1 Connect the CHx HI and CHx LO of the M9185A module to the HI and LO terminal of an ammeter respectively; 'x' denotes the channel number.
- 2 Set the current values and adjust the internal DAC value until the reading on the ammeter falls within the tolerances as shown in [Table 3-5](#). Adjustments should be made according to the top to bottom order of [Table 3-5](#).

**Table 3-5** Current calibration settings and limits

Current settings	Tolerances
0 mA	$\pm 1 \mu\text{V}$
+5 mA	$\pm 1 \mu\text{V}$
+10 mA	$\pm 1 \mu\text{V}$
+15 mA	$\pm 1 \mu\text{V}$
+20 mA	$\pm 1 \mu\text{V}$
-5 mA	$\pm 1 \mu\text{V}$
-10 mA	$\pm 1 \mu\text{V}$
-15 mA	$\pm 1 \mu\text{V}$
-20 mA	$\pm 1 \mu\text{V}$

- 3 Repeat the adjustment for each channel of the M9185A module.

#### NOTE

The tolerances specified are for reference only. When performing calibration, each voltage or current point should be adjusted to the one nearest to the nominal value set before saving the DAC settings. This should guarantee the highest accuracy possible.

When both voltage and current calibrations are done, save the DAC settings. This will write and save the values in an EEPROM on the module. Then run a complete functional test to verify the module is within the specifications listed in [Chapter 1](#), “General Information and Specifications.”

The functional tests for various ranges are as listed in [Table 3-6](#) below.

**Table 3-6** M9185A functional tests list

Test	Voltage/Current	Range	Suggested step size
1	Voltage, 2-wire	-16 V to +16 V	1 V
2	Current	-20 mA to +20 mA	1 mA

**NOTE**

The suggested step size is generally sufficient to verify the functionality of the module after calibration. Testing at finer resolution is possible.

### **3 Performance Verifications and Adjustments**

#### Module Calibration Procedure

THIS PAGE IS INTENTIONALLY LEFT BLANK.



## 4 Replaceable Parts

To Order Replaceable Parts 36

This chapter contains information on ordering replacement parts for your module.



## 4 Replaceable Parts

### To Order Replaceable Parts

## To Order Replaceable Parts

#### NOTE

Parts are listed below according to the reference designators as shown in [Figure 4-14](#) and [Figure 4-15](#). The parts list includes a brief description of each part with applicable Agilent part number.

---

You can order replaceable parts from Agilent using the Agilent part numbers shown in [Table 4-7](#) and [Table 4-8](#). To order the replaceable parts from Agilent, do the following:

- 1 Contact your nearest Agilent Sales Office or Service Center.
- 2 Identify the parts by the Agilent part number shown in the replaceable parts list ([Table 4-7](#) and [Table 4-8](#)).
- 3 Provide the instrument model number and serial number.

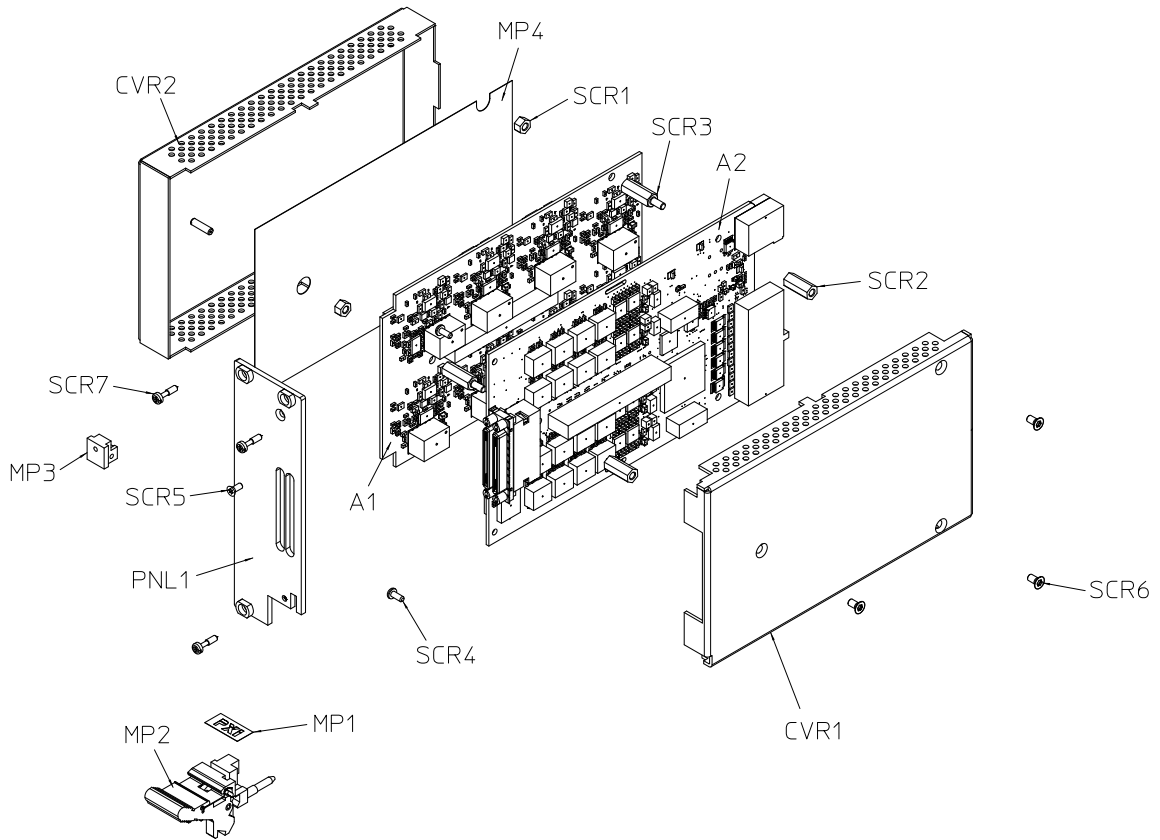

**Figure 4-14** M9185A 8-channel module replaceable parts

## 4 Replaceable Parts

To Order Replaceable Parts

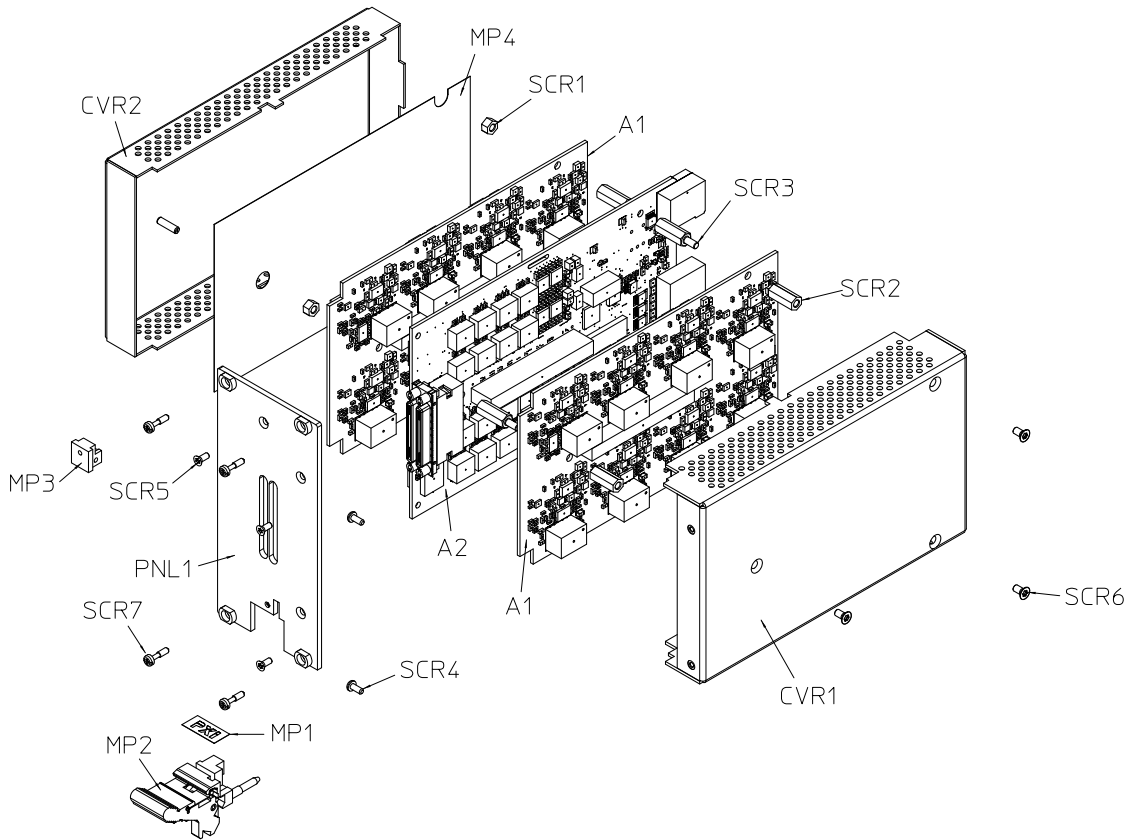

**Figure 4-15** M9185A 16-channel module replaceable parts



**Table 4-7** M9185A 8-channel module replaceable parts list

Reference designator	Agilent part no.	Qty	Description
<b>Exchange assemblies</b>			
A1	M9185-66601	1	PCA- DAC ANALOG
A2	M9185-66602	1	PCA- DAC DIGITAL
<b>Mechanical parts</b>			
PNL1	M9185-00201	1	FRONT PANEL, 8CH DAC
CVR1	M9185-04101	1	TOP COVER, 8CH DAC
CVR2	M9185-04103	1	BOTTOM COVER, DAC
MP1	5183-1633	1	AGILENT LABEL FOR PXI LATCH
MP2	1440-0655	1	HANDLE-ASSEMBLY-INJECTOR-LOWER ALUMINIUM POWER COATED
MP3	1530-2498	1	PCB HOLDER KIT
MP4	M9185-35401	1	INSULATOR, DAC MODULE
SCR1	M9185-02401	3	STANDOFF, M3X3.5 MM, FEMALE
SCR2	M9185-21200	3	STANDOFF, M3X13 MM, FEMALE
SCR3	0380-1631	3	STANDOFF-HEX MALE-FEMALE M3X0.5 6MM-A/F 16MM-LG SST PASSIVATED
SCR4	0515-1940	3	SCREW-MACHINE W/PATCH-LOCK PAN-HD TORX-T8 M2.5X0.45 6MM-LG SST-300 PASSIVATED
SCR5	0515-1375	1	SCREW-MACHINE 90-DEG-FLT-HD TORX-T8 M2.5X0.45 6MM-LG SST-300 PASSIVATED
SCR6	0515-1227	3	SCREW-MACHINE 90-DEG-FLT-HD TORX-T10 M3X0.5 6MM-LG SST-300 PASSIVATED
SCR7	0515-1968	3	SCREW, CONE POINT, 6MM THREAD LENGTH

## 4 Replaceable Parts

### To Order Replaceable Parts

Agilent M9185A 8CH Reference Designators			
A	— Assembly	MP	— Miscellaneous mechanical parts
PNL	— Panel	SCR	— Screw or fastener
CVR	— Cover		

**Table 4-8** M9185A 16-channel module replaceable parts list

Reference designator	Agilent part no.	Qty	Description
<b>Exchange assemblies</b>			
A1	M9185-66601	2	PCA- DAC ANALOG
A2	M9185-66602	1	PCA- DAC DIGITAL
<b>Mechanical parts</b>			
PNL1	M9185-00201	1	FRONT PANEL, 16CH DAC
CVR1	M9185-04101	1	TOP COVER, 16CH DAC
CVR2	M9185-04103	1	BOTTOM COVER, DAC
MP1	5183-1633	1	AGILENT LABEL FOR PXI LATCH
MP2	1440-0655	1	HANDLE-ASSEMBLY-INJECTOR-LOWER ALUMINIUM POWER COATED
MP3	1530-2498	1	PCB HOLDER KIT
MP4	M9185-35401	1	INSULATOR, DAC MODULE
SCR1	M9185-02401	3	STANDOFF, M3X3.5 MM, FEMALE
SCR2	M9185-21200	3	STANDOFF, M3X13 MM, FEMALE
SCR3	0380-1631	6	STANDOFF-HEX MALE-FEMALE M3X0.5 6MM-A/F 16MM-LG SST PASSIVATED
SCR4	0515-1940	3	SCREW-MACHINE W/PATCH-LOCK PAN-HD TORX-T8 M2.5X0.45 6MM-LG SST-300 PASSIVATED
SCR5	0515-1375	3	SCREW-MACHINE 90-DEG-FLT-HD TORX-T8 M2.5X0.45 6MM-LG SST-300 PASSIVATED

**Table 4-8** M9185A 16-channel module replaceable parts list (continued)

Reference designator	Agilent part no.	Qty	Description
SCR6	0515-1227	3	SCREW-MACHINE 90-DEG-FLT-HD TORX-T10 M3X0.5 6MM-LG SST-300 PASSIVATED
SCR7	0515-1968	3	SCREW, CONE POINT, 6MM THREAD LENGTH

**Agilent M9185A 16CH Reference Designators**

A	— Assembly	MP	— Miscellaneous mechanical parts
PNL	— Panel	SCR	— Screw or fastener
CVR	— Cover		

## **4 Replaceable Parts**

To Order Replaceable Parts

THIS PAGE IS INTENTIONALLY LEFT BLANK.

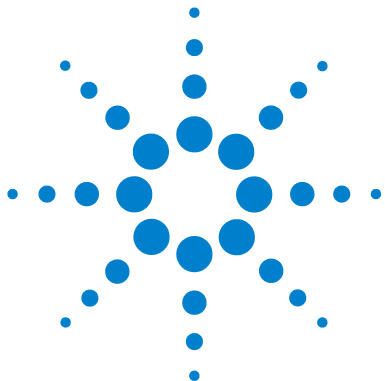

## 5 Service

Troubleshooting Techniques	44
Identifying the problem	44
Repair/Maintenance Guidelines	45
ESD precautions	45
Post-repair safety checks	46
Agilent Technologies Calibration Services	47
Calibration interval	47
Types of Service Available	47
Extended Service Contracts	48
Obtaining Repair Service (Worldwide)	48
Re-packaging for Shipment	49
Cleaning	49

This chapter contains information on servicing the module, and it includes troubleshooting guidelines and repair/maintenance guidelines.

**WARNING**

**Do not perform any of the service procedures unless you are a qualified service personnel.**

---



## Troubleshooting Techniques

There are two main steps to troubleshoot a faulty M9185A module:

- 1 Identify the problem, and
- 2 Test the module assembly to isolate the cause.

### Identifying the problem

Module problems can be divided into three general categories:

- Operator errors
- Catastrophic failures
- Performance out of specification

#### Operator Errors

Apparent failures may result from operator errors.

#### Catastrophic Failure

If a catastrophic failure occurs, use the M9185A Soft Front Panel (SFP) to communicate with the module in order to troubleshoot and isolate the module problem.

#### Performance out of specification

If the module performance is out of specification limits, use the adjustment/calibration procedures in [Chapter 3](#) to correct the problem.

## Repair/Maintenance Guidelines

This section provides guidelines to repair and maintain the M9185A module, including:

- ESD precautions
- Soldering printed circuit boards
- Post-repair safety checks

### ESD precautions

Electrostatic discharge (ESD) may damage MOS, CMOS, and other static sensitive devices in the M9185A module. This damage can range from slight parameter degradations to catastrophic failures.

When handling module assemblies, follow these guidelines to avoid damaging module components:

- Always use a static-free work station with a pad of conductive rubber or similar material when handling module components.
- After you remove the module from the mainframe, place the module on a conductive surface to guard against ESD damage.
- After you remove a MOS or CMOS device from an assembly, place the device onto a pad of conductive foam or other suitable holding material.
- If a device requires soldering, be sure that the assembly is placed on a pad of conductive material. Also, be sure you, the pad, and the soldering iron tip are grounded to the assembly. Apply as little heat as possible when soldering.
- When you replace a MOS or CMOS device, ground the foam before removing the device from the foam.

When soldering to any circuit board, keep in mind the following guidelines:

- Avoid unnecessary component unsoldering and soldering. Excessive replacement can result in damage to the circuit board and/or adjacent components.
- Do not use a high power soldering iron on etched circuit boards as excessive heat may lift a conductor or damage the board.
- Use a suction device or wooden toothpick to remove solder from component mounting holes. When using a suction device, be sure the equipment is properly grounded to prevent electrostatic discharge from damaging CMOS devices.

## **Post-repair safety checks**

After making repairs to the M9185A module, inspect the module for any signs of abnormal internally generated heat, such as discolored printed circuit boards or components, damaged insulation, or evidence of arcing. Determine and correct the cause of the condition. Then run the Verification Tests to verify that the module is functional.



## Agilent Technologies Calibration Services

When your module is due for calibration, contact your local Agilent Service Center for a low-cost recalibration. The M9185A is supported on automated calibration systems, which allows Agilent to provide this service at a competitive price.

### Calibration interval

A one-year interval is adequate for most applications. Accuracy specifications are under warranty only if adjustments are made at regular calibration intervals. Accuracy specifications will not be offered warranty beyond the one-year calibration interval. Agilent does not recommend extending calibration intervals beyond two years for any application. Agilent recommends that a complete readjustment should always be performed at the calibration interval. This will ensure that the M9185A will remain within specifications for the next calibration interval. The re-adjustment provides the best long-term stability and accuracy.

### Types of Service Available

If your instrument fails during the warranty period, Agilent will repair or replace it under the terms of your warranty. After your warranty expires, Agilent offers repair services at competitive prices.

## Extended Service Contracts

Most Agilent products are provided with optional service contracts that extend the coverage period after the standard warranty expires. If you have this service contract and your instrument happens to fail during the coverage period, Agilent will repair or replace it according to the contract.

## Obtaining Repair Service (Worldwide)

To obtain service for your instrument (in-warranty, under service contract, or post-warranty), contact your nearest Agilent Service Center. They will arrange to have your unit repaired or replaced, and are able to provide warranty or repair cost information where applicable. To obtain warranty, service, or technical support information you can contact Agilent at one of the following telephone numbers.

- In the United States: 800 829 4444
- In Europe: 31 20 547 2111
- In Japan: (81) 426 56 7832

You can also use our Web link for the information on contacting Agilent worldwide:

[www.agilent.com/find/assist](http://www.agilent.com/find/assist)

Or contact your Agilent representative.

Before shipping your instrument, ensure that you acquire shipping instructions, including the components to be shipped, from the Agilent Service Center. Agilent recommends that you retain the original shipping carton for use in such shipments.

## Re-packaging for Shipment

If the unit is to be shipped to Agilent for service or repair, make sure that you do the following.

- Attach a tag to the unit identifying the owner and indicating the required service or repair. Include the model number and full serial number.
- Place the unit in its original container with appropriate packaging material for shipping.
- Secure the container with strong tape or metal bands.
- If the original shipping container is not available, place your unit in a container with at least four inches of compressible packaging material around all sides for the instrument. Use static-free packaging materials to avoid additional damage to your unit.

### NOTE

Agilent suggests that you always insure your shipments.

---

## Cleaning

Clean the outer area of the module with a soft, lint-free, and slightly dampened cloth. Do not use detergent.

Disassembly is not required for cleaning.

THIS PAGE IS INTENTIONALLY LEFT BLANK.

**www.agilent.com**

**Contact us**

To obtain service, warranty, or technical assistance, contact us at the following phone or fax numbers:

United States:

(tel) 800 829 4444 (fax) 800 829 4433

Canada:

(tel) 877 894 4414 (fax) 800 746 4866

China:

(tel) 800 810 0189 (fax) 800 820 2816

Europe:

(tel) 31 20 547 2111

Japan:

(tel) (81) 426 56 7832 (fax) (81) 426 56 7840

Korea:

(tel) (080) 769 0800 (fax) (080) 769 0900

Latin America:

(tel) (305) 269 7500

Taiwan:

(tel) 0800 047 866 (fax) 0800 286 331

Other Asia Pacific Countries:

(tel) (65) 6375 8100 (fax) (65) 6755 0042

Or visit Agilent World Wide Web at:

[www.agilent.com/find/assist](http://www.agilent.com/find/assist)

Product specifications and descriptions in this document are subject to change without notice. Always refer to Agilent Web site for the latest revision.

© Agilent Technologies, Inc., 2010-2011

Fourth Edition, May 23, 2011  
M9185-90010



**Agilent Technologies**